

**ROPE AND ROPE-MAKING.** All varieties of cordage having a circumference of an inch or more are known by the general name of "rope." Twisted cordages of smaller dimensions are called cords, twines and lines, and when the sectional area is still smaller, the article is known as thread or doubled yarn. All these varieties of cordage are composed of a number of separate yarns, each of which is made from some kind of textile fibre by preparing and spinning machinery. The number of separate yarns which ultimately form the rope or cord depends upon the fineness of the yarn, and also upon the circumference of the finished article. From thread and fine twine upwards the whole art of manufacture is that of twisting together fibres and yarns; but the comparative heaviness and coarseness of the materials operated on in rope-making render necessary the adoption of heavy machinery and modified processes which clearly define this manufacture as a distinct calling. The modern trade of rope-making is again divided into two distinct branches dealing with vegetable fibres and metallic wire.

Many different vegetable fibres are used for rope-making, but for the combined qualities of strength, flexibility and durability, none can compete with the common hemp, which is consequently the staple of the rope-maker. Cotton ropes are, however, much more flexible, and in addition are strong and durable; they are, therefore, much preferred for power transmission in textile and other works. Manila hemp is a fibre of remarkable tenacity, of unapproached value for heavy cordage, but too stiff for small cords and twines. After these in utility come Sisal hemp of Central America (*Agave Sisalana*), Phormium hemp of New Zealand (*Phormium tenax*) and Sunn hemp of the East Indies (*Crotalaria juncea*)—all fibres of great strength, and largely used by rope-makers. Jute (*q.v.*) of India (*Corchorus capsularis* and *C. olitorus*) is now largely used by rope-makers on account of its cheapness. When used alone it is deficient in strength and durability, but when used in conjunction with proper proportions of hemp it makes a very satisfactory and useful rope. Among fibres more rarely seen in rope-works are Jubbulpore hemp (*Crotalaria tenuifolia*), boxstring hemp (*Sansevieria zeylanica*), and other hems of the East Indies, plantain fibre (*Musa paradisiaca*), and agave fibre (*Agave americana*) of America. Coir and many other fibres are used, but principally in the localities of their production.

A rope is composed of a certain number of "strands," the strand itself being made up of a number of single threads or yarns. Three strands laid or twisted together form a "hawser-laid" rope, and three such hawsers similarly laid make a "cable-laid" rope or "cable." A "shroud-laid" rope usually consists of four strands laid around a central strand or core. The prepared fibre is twisted or spun to the right hand to form yarn; the required number of yarns receive a left-hand twist to make a strand; three strands twisted to the right make a hawser; and three hawsers twisted to the left form a cable. Thus the twist in each operation is in a different direction from that of the preceding one, and this alternation of direction serves, to some extent, to preserve the parallelism of the fibres.

The primary object of twisting fibres together in a rope is that by mutual friction they may be held together when a strain is applied to the whole. Hard twisting has the further advantage of compacting the fibres and preventing, to some extent, the penetration of moisture when the ropes are exposed to water; but the yield of rope from a given length of yarn diminishes in proportion to the increase of twist. The proper degree of twist given to ropes is generally such that the rope is from three-fourths to two-thirds the length of yarn composing it.

*Rope-walk Spinning.*—The sequence of operations in this method of working is as follows: (1) hackling the fibre; (2) spinning the yarn; (3) tarring the yarn when necessary; (4) forming the strands; (5) laying the strands into ropes.

Hackling differs but slightly from the hand-hackling process used in the preparation of flax. The hackle board consists of a wooden block studded with strong, tapered and sharp-pointed steel prongs. A series of such hackle boards is used in the progressive hackling operation, the prongs diminishing

in size and being more closely set together. For the commoner kinds of ropes, however, hackling through the coarsest board is found to be sufficient, while in most other cases two hacklings are adopted.

The hackler takes up a handful or "streak"<sup>1</sup> of hemp from the bundle, wraps one end firmly round his hand, and with his fingers distributes a little oil over the hemp. The oil softens the material, keeps the hackle pins in good condition, and facilitates generally the splitting up of the fibre as the streak is drawn through the pins. In the first place, only the ends of the streak are hackled; they are dashed into the pins and drawn through them in order to separate the fibres and to lay them parallel; but as the operation proceeds a gradually increasing length of the streak is thrown on and drawn through the pins. The process is indeed very similar to the combing out of a head of human hair. When half the length of the streak is thoroughly combed, the other half is treated in precisely the same manner. The hackled streak is then weighed, doubled up to prevent any entanglement, and laid aside for the process of spinning. During the hackling process a large quantity of comparatively short fibres are retained in the pins; the longest of these are separated, and the remainder used for tow yarns. The above description refers entirely to hand hackling; machine hackling of hemp is very similar to fax hackling.

The spinning is done in what is termed the "rope-walk," and from the nature of hand-spinning, and the length of the rope required, it is necessary that this walk should be from 300 to 400 yds. in length. It is sometimes completely covered in with walls and roof; at other times only a roof is built; while in exceptional cases the whole of the walk, with the exception of a small hut at each end, is without shelter of any kind. The operation of spinning is very important, as the weight of the yarn and the appearance of the finished product depend upon it. A description of spinning and laying as performed by the aid of the hand-wheel will perhaps be the best means of giving an idea of this useful branch of manufacture.

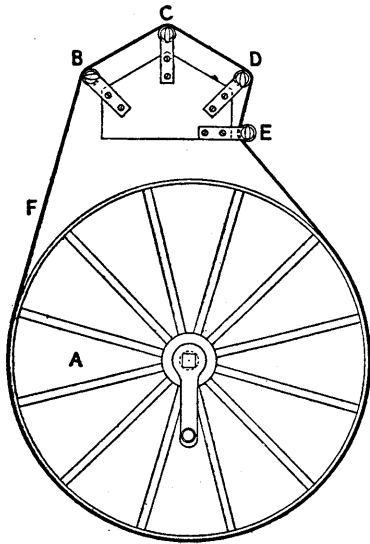

FIG. 1.

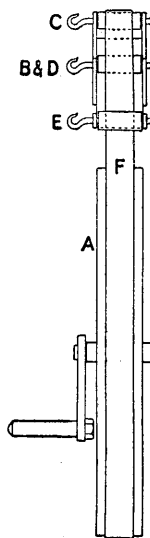

FIG. 2.

The front and end elevations of one variety of spinning-wheel are shown in figs. 1 and 2. The apparatus is fixed to some convenient part of the building, or to special supports. The wheel A, which is turned by hand, and always in the same direction, communicates motion to the rotating hooks or "whirls" B, C, D and E by means of a listing band or strap F. The arrangement of the listing shows clearly that the hook E will revolve in the opposite direction to hooks B, C, and D. The spinner takes two streaks of the hackled hemp, wraps them round his waist with the ends at his back, and keeps the fibre in position by adjusting his apron partly round it. From the middle of the streak—that is, midway between the two ends—he takes hold of a quantity of fibre and hangs it on to one of the

hooks B, C or D; the assistant at the wheel begins to turn, and thus a certain amount of twist is imparted to the material between the spinner and the hook. The spinner now walks backwards down the walk, drawing out the fibre with his left hand and adjusting it with his right. A piece of flannel or woollen cloth held in his right hand aids in the formation of the thread and protects his fingers from the rough fibre. In some cases two threads are spun simultaneously; when this is done, two of the hooks, say B and C, are used at the same time. Since the revolutions of the hook divided by the length of yarn spun give the amount of twist per inch or foot, it follows that the ratio of the walking pace of the spinner to the revolutions of the wheel A should be constant, otherwise the yarn will not be uniform. The spinner calls to the assistant when there is any irregularity in speed, or when, from any cause, he is obliged to stop walking.

At convenient intervals in the length of the walk, and projecting from posts, are short horizontal bars; the top of each bar is provided with wires or pegs to form a number of vertical partitions something like a very coarse comb. As the spinner proceeds down the walk, he throws the spun yarn into one of these partitions, thus relieving himself of the weight and keeping the yarn off the ground. When a sufficient length of yarn has been spun, he breaks off the fibres and fastens the yarn to a convenient peg or hook until he has spun a sufficient number (usually three) to form a small rope or cord. The person at the wheel hangs these three yarns one on each of the three hooks B, C and D, while the spinner attaches the other ends to a revolving hook termed a "looper." All is now ready for "laying" the yarns. For small cords, this may be done, with or without a "top." This top is a conical-shaped piece of hard wood provided with three equidistant grooves which merge towards each other at the thin end, and into which the yarns are laid. The thick end of the top is nearest the wheel, so that the yarns may be kept separate on that side. As the hooks twist the three threads, the spinner goes up the walk with the top; the twist in the yarns causes the looping hook to revolve in the opposite direction to the other hooks, and thus it twists the three threads in the opposite direction to the original twist.

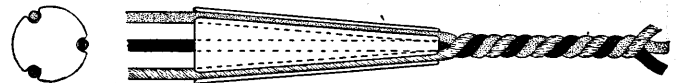

FIG. 3.

Fig. 3 shows one form of top, the three yarns being shown in distinctive marks so that the path of each may be more easily followed by the reader; a plan of the thick end of the top appears to the left of the figure. If four yarns of strands are required, the top would contain four grooves, as well as a hole through the centre to admit of a core when such a thing is required. As soon as the spinner, who carries the top, arrives at the wheel, the assistant takes the yarns off hooks B, C and D (figs. 1 and 2), and puts them all on hook E. The other ends of the strands are removed from the looper and attached to a block of wood called a "drag." The wheel is then rotated as before, which puts more twist into the cord. While this operation, which is termed hardening, proceeds, a shrinkage in the length of the cord takes place, and the drag is consequently drawn up the walk. The drag, however, holds the cord taut, and serves to retain the twist which is imparted by the hook E.

If the strands require tarring before they are laid, they are separately taken off the hooks, after they have been spun, and tied at both ends to pegs to keep them taut until a sufficient number has collected to be conveniently handled at the tarring tank. The tar is heated to about 220° F., and the strands are then passed through it at a speed not greater than 15 ft. per minute. Before emerging from the tank, the strands pass between squeezing rollers which remove all superfluous tar. In a short time the strands are dry, while in the space of a few days the tar is hard enough to allow the strands to be formed into ropes.

Such is, in general, the hand process of forming ropes when they are composed of only three or four single yarns. It very often happens, however, that a number of single yarns are required to form each strand of the rope. The single yarns may be spun by hand, as described above, or by machinery. In the former case a group of yarns is usually termed a "haul," while the machine-spun yarns are formed into what is known as a "warp" or "chain." In any case, the group of yarns is stretched down the rope-walk, at each end of which is a "jack" twister. A few of the yarns taken from the group—the number depending upon the size of the yarn and also upon the required diameter of the strand—are then placed on a hook of the jack twister and twisted together. When three such strands are made they are laid into a rope in a similar manner to that explained above. A simple form of hand jack twister is illustrated in figs. 4 and 5. The wheel A gears with pinions B on the shafts of the hooks or whirls, and this imparts the necessary motion to the latter. At the other end of the walk is a similar machine which moves upon rails as the twist is put into the strands. When the hooks are empty, pinions B and wheel A (fig. 4) are out of gear, but those hooks carrying yarn are drawn out, as shown at C, until the pinion B gears with wheel A, when the hooks are rotated. The

<sup>1</sup> See note in the article on JUTE for variations of spelling.

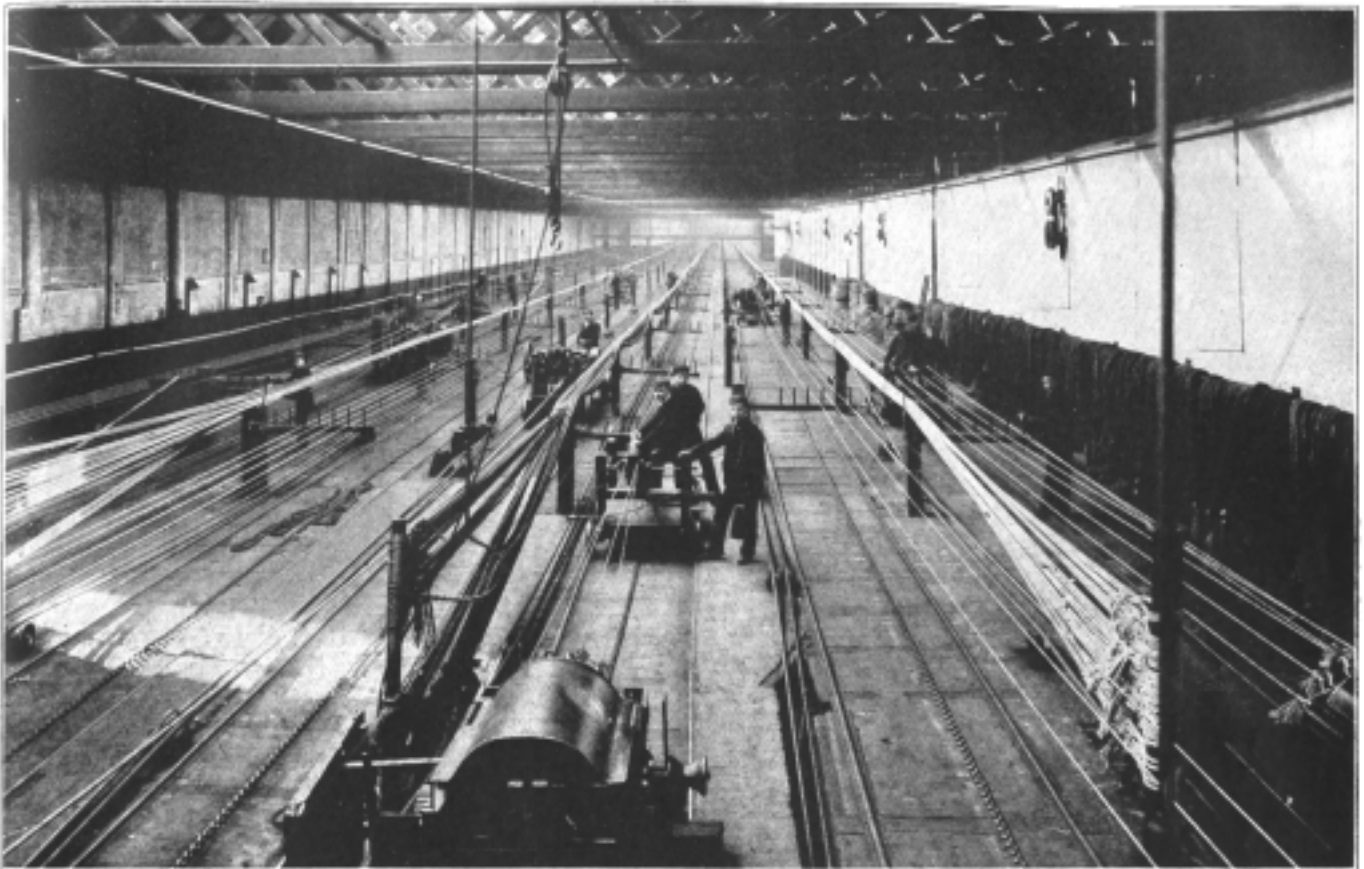

FIG. 9.—ROPE-MAKING, POTTINGER MILL.

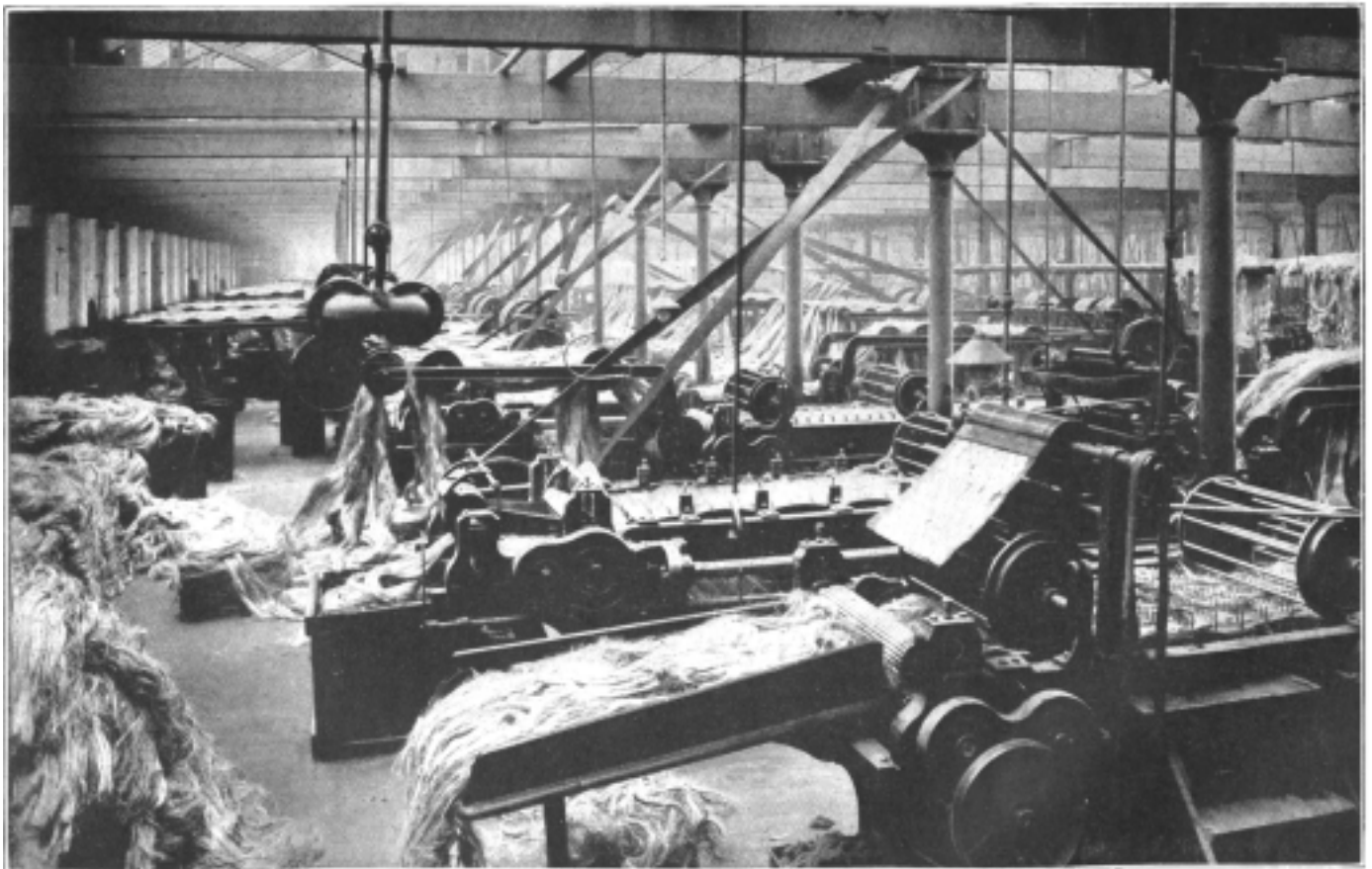

FIG. 10.—MANILA ROPE YARN PREPARING, POTTINGER MILL, OF THE BELFAST ROPEWORK CO. LTD.  
XXIII 714.

ROPE AND ROPE-MAKING

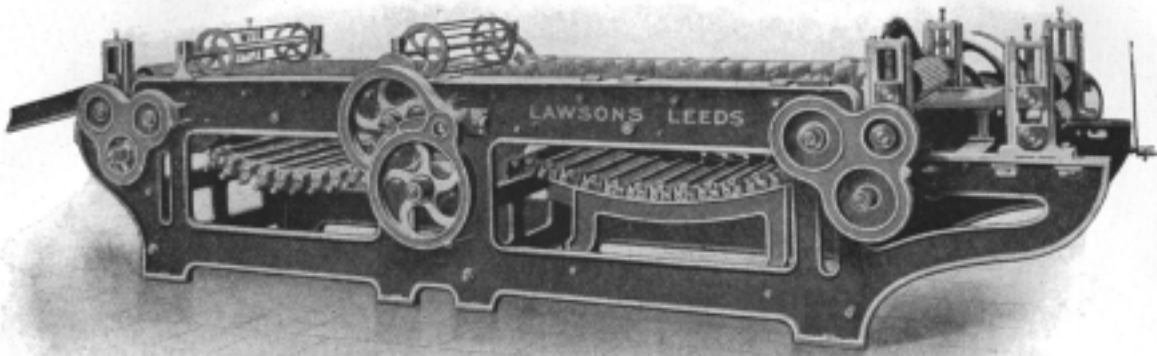

FIG. 11.—GOOD'S HACKLING AND SPREADING MACHINE.

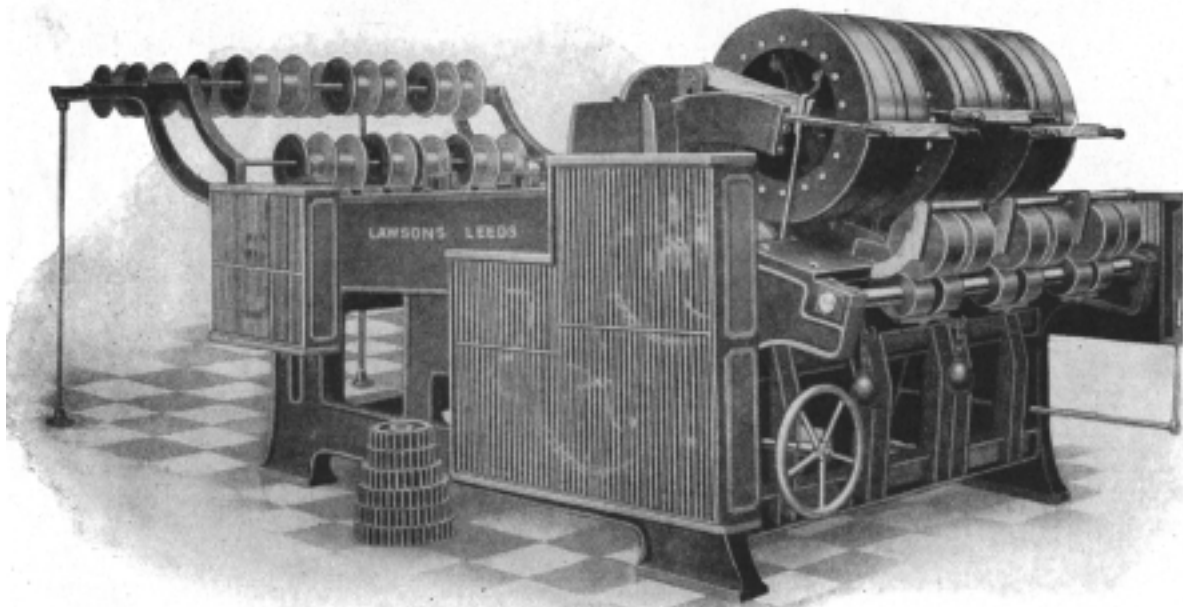

FIG. 12.—HEAVY SPIRAL OR SCREW-GILL DRAWING FRAME; ONE HEAD, SIX GILLS.

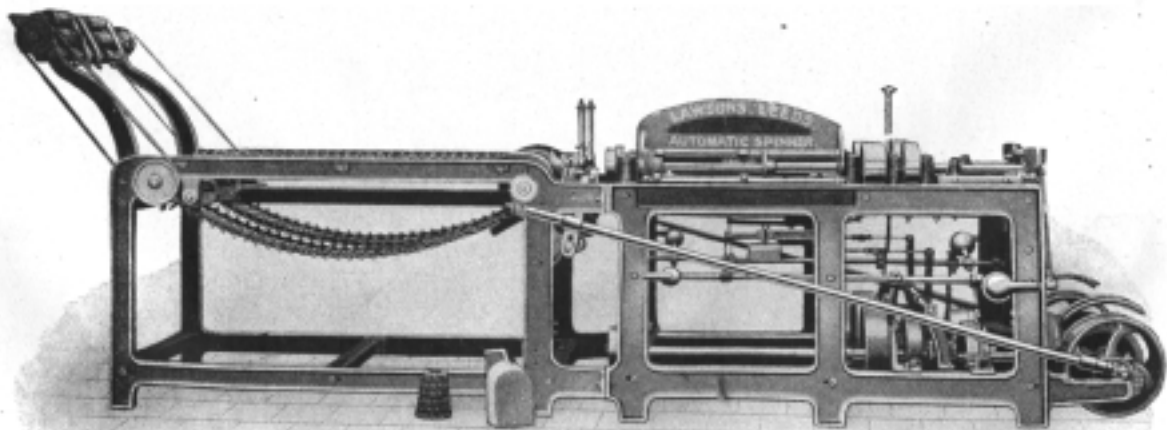
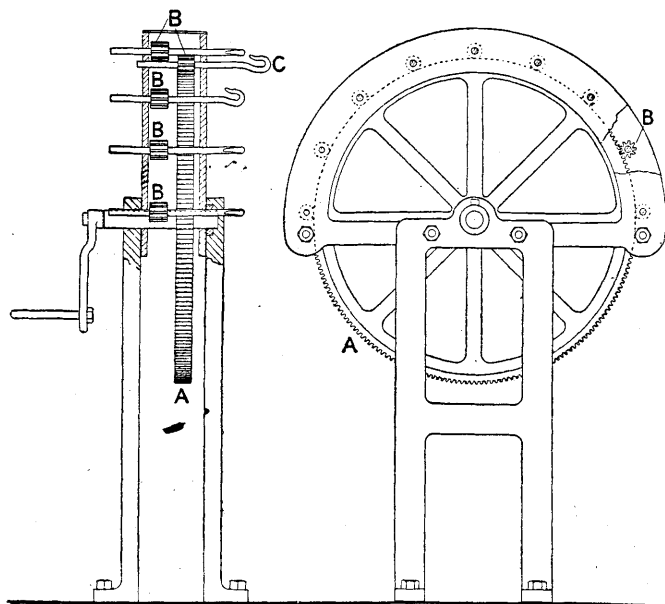

FIG. 13.—SPINNER OR JENNY.

sequence of operations is very similar to that described for the simple hand-wheel.



Figs. 4 and 5.

*Machine or Factory Rope-Making.*—The most modern methods of rope-making are far superior to the foregoing, which, as stated, have been introduced to show the principle. One of the greatest drawbacks in the formation of a strand from a haul or chain, even for a small number of yarns, is the irregularity of the tension of the yarns at different parts of the strand. If a large number of yarns be required for each strand, it would be almost impossible to make a satisfactory rope by the above system. If, however, the strand be made from bobbins, each yarn bears its proper share of the tension, and an almost perfect rope is obtained.

Two mechanical methods are in use for the spinning of long vegetable fibres—the ordinary and the special. When flax or jute yarns are required, they are almost invariably spun on the ordinary spinning frames, and the yarn rewound from the spinning bobbins on warping bobbins, or else rewound in the shape of rolls or cheeses. Hemp yarns, especially the finer kinds, are sometimes treated in the same manner, but Manila hemp, New Zealand hemp (*Phormium*), and similar fibres, are invariably spun on bobbins by special machinery. The strands for light ropes may then be made on the twisting frames, and the rope finished on what is called a “house machine.” When a large rope is desired, a slightly different method is usually employed. The bobbins from the automatic spinner, or the rolls from the winding frame, are placed upon pegs in a frame which answers the same purpose as a bank or creel used in conjunction with a warping machine. If the rope is to be say  $3\frac{1}{2}$  in. in circumference, there may be, with fine yarns, 300 or more individual threads in its composition. Suppose that 300 threads are to be used, then 300 bobbins would be placed on the pegs of the bobbin bank or creel, and divided into three sets of 100 threads each for a three-strand rope. The threads are passed separately through a register plate, which is simply a plate containing a sufficient number of holes for the maximum quantity required, and arranged in a series of concentric circles. There are three sets of concentric rings used in the plate for a three-strand rope, and four sets for one of four strands. As the threads emerge from the register plate they are grouped together and passed through a tapered tube, the sectional area of the smaller end of the tube being equal to the sectional area of the strand. This operation is done for each group of 100 threads, and finally the three or four groups are attached to separate rotating hooks of the forming machine or “traveller.” As the latter moves down the walk on rails, it draws the threads from the bobbins in the bank, and through

the register plate and tubes, while the hooks put in the twist. A perfectly circular strand, without slack threads, is thus formed; and, at the same time, a uniform strand is obtained, since the ratio of the speed of the traveller to the number of turns per inch of the hooks is constant. The process is continued until the desired length of strand is made—about 150 fathoms (300 yds.) of each of the three strands are required for 100 to 120 fathoms of rope—then a little more twist is introduced. Afterwards, all three strands are placed on one hook of the traveller, and the ends from the shaping tubes are cut off and put on the hooks of the fixed machine, called the “fore-turn.” The carriage containing the “top” is now brought close to the traveller, and the strands are placed in the grooves of the top as explained under hand-laying. Similar means to those used in hand-spinning are adopted for keeping the rope off the ground. The two machines are now started, the three hooks of the fore-turn machine revolving in one direction and the single hook of the traveller revolving in the opposite direction. Simultaneously the carriage with the laying top moves forward towards the head of the walk.

Fig. 9, Plate I., shows many stages in the process of rope-making. The most prominent part shows the carriage with the top in position approaching the fore-turn machine at the head of the walk. The person on the right of the carriage is holding a top in his left hand, while the top in the carriage is laying a rope of four strands. At other parts of the figure appear three or four travellers, some twisting the strands, others moving up the walk as the laying proceeds, while on the extreme right one machine is laying two ropes, of three strands each, at the same time.

We have already stated that the yarns for the above machine may be prepared by two systems. When the hemp fibre is spun on the ordinary frame, the method of preparation for such a frame is somewhat similar to that employed for flax, but since the fibre is harsher than flax, it invariably requires softening. The softening machines crush the streaks as in the case of jute, but the fluted rollers are arranged to form part of a circle. The coarser fibres receive a somewhat different treatment; the first process in the preparation of Manila hemp and similar fibres used for rope yarn is illustrated in fig. 10, Plate I. The streaks are clearly shown as being led between fluted rollers on to the pins of the hackling and spreading machine; the lanterns or skeleton rollers, seen on the extreme right, press the fibres into the pins. A little oil is made to drop on to the fibre in order to soften it and to facilitate the operation. The oiling apparatus is usually of a simple character, and consists of a revolving roller partly immersed in an oil bath. The roller is driven as shown in the figure, and the oil which it draws up is scraped off its surface by a knife-edge, and led, by means of a sheet, upon the fibre between the fluted rollers and the gill-pins. A view of a similar machine is shown in fig. 11, Plate II., from which it will be seen that there are two sheets of revolving gill-pins. The sheet nearest the feed-cloth revolves slightly quicker than the surface speed of the fluted feed rollers, while the second sheet moves at a much higher rate. The difference in the speeds of the gill-pins results in the fibre being combed out and straightened, while the delivery rollers, the surface speed of which is slightly greater than that of the second sheet of gill-pins, help further to complete the process, and finally deliver the fibre in the form of a broad ribbon, termed a sliver.

In general, three such machines are used for the process; the pins in the gill-sheets are graded, those in the second machine being finer and more closely set than those in the first machine, while a still finer and closer arrangement obtains in the third machine. The slivers from the third hackling and spreading machine are now placed at the back of the first drawing frame, one type of which appears in fig. 12, Plate II. Each sliver is passed separately over a guide pulley, led upon the pins, drawn out and joined by others, and finally delivered as a sliver ready for the second drawing frame. A similar process is carried on in this machine, from which the sliver emerges ready for the spinning frame. It will thus be seen that a system of doubling, as well as of drawing, obtains in these processes as in flax-preparing; such a system is adopted in order to obtain uniformity of sliver and the correct weight.

The slivers are taken from the drawing frame to the automatic spinner—a beautiful piece of mechanism. Fig. 13, Plate II., illustrates the machine as it leaves the makers. Two sliver cans from the second drawing frame are placed behind the machine, and the slivers passed between the rollers. They are then deflected and made to enter a trumpet-mouthed conductor which guides them on to the pins of the chain-sheet. As the two slivers emerge from these pins, each enters a separate self-feeding and adjusting apparatus, the function of which is, as its name implies, to regulate the delivery of the sliver to the nippers. The delivery is increased or decreased according as the sliver is thin or thick. Consequently, a very even yarn results; indeed, it is claimed that for uniformity of yarn this system of spinning has no equal. The bobbins, which

are placed in a horizontal position, have a lateral movement, so that the finished yarn may be wound on evenly. This machine is made for ordinary rope yarn, and for binder twine for self-reaping machines. When all three spreading machines are used in conjunction with the spiral drawing frames, the automatic feeding arrangement is sometimes considered unnecessary, because of the uniformity of the slivers when delivered from the finishing drawing frame.

Figs. 14 and 15, Plate III., show two sheds filled with preparing machinery for the manufacture of binder twine. A complete system of Manila machinery, as recommended by Messrs Lawsons, Leeds, would consist of the following:—

1 No. 1 spreading and hackling machine.

1 " 2 " " " "

1 " 3 " " " "

1 spiral 1st drawing frame, 1 head, 88 in. reach, 4 slivers per head.

1 " 2nd " " 2 heads, 88 in. " 6

20 improved automatic spinners or jennies of 2 spindles each.

The length of sliver from a given length of fibre is proportional to the drafts and inversely proportional to the doublings. Thus, if

$d_1, d_2, d_3, d_4, d_5, d_6$  = the drafts,

$s_1, s_2, s_3, s_4, s_5, s_6$  = the number of slivers,

$l$  = the feet per lb on the feed-table of No. 1 spreading machine,

$L$  = the feet per lb delivered at the automatic spinner, then:—

$$l \times \frac{d_1}{s_1} \times \frac{d_2}{s_2} \times \frac{d_3}{s_3} \times \frac{d_4}{s_4} \times \frac{d_5}{s_5} \times \frac{d_6}{s_6} = L.$$

No. 1.	No. 2.	No. 3.	No. 1.	No. 2.	Auto-
Spreading	Spreading	Spreading	Drawing	Drawing	matic
machines.	machines.	machines.	frames.	frames.	spinner.

A numerical example, showing the drafts, slivers, &c., used for the production of No. 22<sup>s</sup> rope yarn of 330 ft. per lb appears below:—

$$l \times \frac{15.5}{1} \times \frac{15.5}{12} \times \frac{15.5}{12} \times \frac{7.42}{4} \times \frac{9.7}{4} \times \frac{5\frac{3}{8}}{1} = 330 \text{ ft.}$$

Spreading  
machines.

Drawing  
frames.

Automatic  
spinner.

Whence  $l = .536$  ft., say .54 ft. per lb; that is to say, 1 lb of Manila fibre, approximately 6 in. in length, spread on the feed-table of No. 1 spreading and hackling machine, and subjected to the above drafts and doublings, would produce yarn No. 22<sup>s</sup> of 330 ft. per lb from the automatic spinner.

The bobbins from these automatic spinners may be used in the bank at the rope-walk as already indicated, or they may be taken to what is termed a "house machine." These machines are of two distinct kinds—vertical and horizontal. They perform the same work as the machines in the rope-walk, but take up much less space.

Figs. 16 and 17, Plate IV., illustrate two types of horizontal machines, each of which is capable of completing a rope in one operation. The process is pretty clear in fig. 17, which shows that eighteen threads are treated at once. On the right, and driven by spur gearing, are three revolving carriages or creels, each containing six bobbins. Each group revolves as the yarns are drawn off the bobbins, and thus the threads are formed into three strands. As the strands emerge from the guides, they converge towards three other guides, are laid together, and finally the finished rope is wound on to the reel.

In principle the vertical machine is the same as the horizontal machine, and the rope is, consequently, made in one operation. Any number of bobbins, from 24 to 128, may be twisted at the same time; the machine in fig. 18, Plate IV., is for making a rope of three strands, each with 12 threads, or 36 threads in all. These machines are also made to make ropes of four strands. The strands are formed by the rotation of the carriages, from the top of which each strand passes. The three strands then converge to, and pass through, the top of the machine, where they are laid into a rope. The latter passes over a series of guide pulleys, and is ultimately wound on the large drum shown in front of the machine. Such a machine for making a 128-thread, four-strand rope, occupies only about 125 sq. ft.—8 ft. 9 in.  $\times$  14 ft. 4 in.

In addition to the heavy rope there are many varieties of cord and twine made by means of the preparing, spinning and doubling machines. The fishing industry takes many different types for lines and nets, while the variety of cord and twine for other industrial and for household purposes is almost unlimited. All yarn from long vegetable fibre is more or less rough as it leaves the spinning frame, even after two or more threads have been twisted together. It is therefore necessary, for many uses, to impart a polish to the cord or twine. Special machines are used for this purpose. A certain number of bobbins, depending upon the capacity of the machine, are placed in a bank, and the ends are collected and passed under a roller which is immersed in hot starch. The yarns become saturated

with this starch, but, as they emerge from the starch-box, the superfluous starch is removed by passing the yarns between two rollers. The yarns now pass over a series of drying cylinders and polishing rollers, and are finally rewound by the same machine on bobbins. These machines are termed bobbin-to-bobbin polishing machines. In some cases the hot drying cylinders are replaced by a system of hot air drying. The finished yarns are now made up by machinery into hanks, balls or cheeses, according to which happens to be the best state for future use and for transport.

*Driving Ropes.*—It has already been stated that cotton driving ropes are extensively applied in the transmission of motive power. Although the mechanical efficiency of transmission by ropes is less than that obtained by wheel gearing, rope driving has several compensating advantages:—

1. It is practically noiseless.
2. It occupies less space than belt driving, and the slip is not so great.
3. The turning movement is better; machines therefore run more steadily and production is increased.
4. Shafts may be run at higher speeds.
5. Greater range of drives; anything from 10 ft. to over 80 ft., and much greater distances when carrier pulleys are used.
6. The drive is usually obtained by a number of ropes; if one should break, the rope may be removed and the machinery run, in most cases, until stopping-time.

The number of ropes to be used depends upon the power to be transmitted and upon the surface speed of the driving pulley. The speed of the rope may vary from 2000 ft. to 6000 ft. or over per minute. In some few exceptional cases 60 ropes have been used on one pulley; the number usually varies between 15 and 40. (See also POWER TRANSMISSION, § *Mechanical*.) Fig. 6 shows the

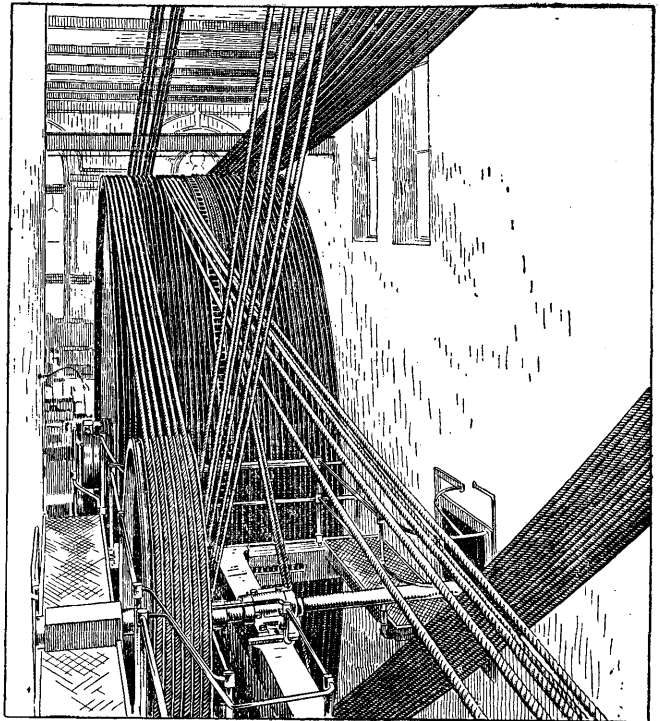

FIG. 6.—Rope Race of a Lancashire Cotton-Spinning Mill, with 38 Lambeth Cotton Driving Ropes, 1½ in. diameter; engine, 1700 H.P.

application of these ropes, which pass direct from the main driving pulley to the different flats of the mill. Fig. 7 shows the construction of the Lambeth four-strand cotton rope.

There are two distinct systems of arranging the ropes on the driver and the driven pulleys. In the United Kingdom each rope is independent of all the others, and, as it is unlikely for more than one rope to break at a time, the stoppages are reduced to a minimum. In America, where hemp ropes are largely employed,

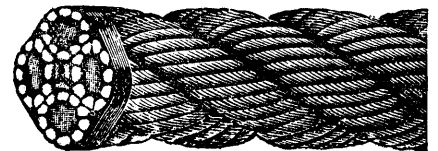

FIG. 7.—Lambeth Cotton Rope.



FIG. 14.—BINDER TWINE PREPARING, CONNSWATER MILL, OF THE BELFAST ROPEWORK CO. LTD.

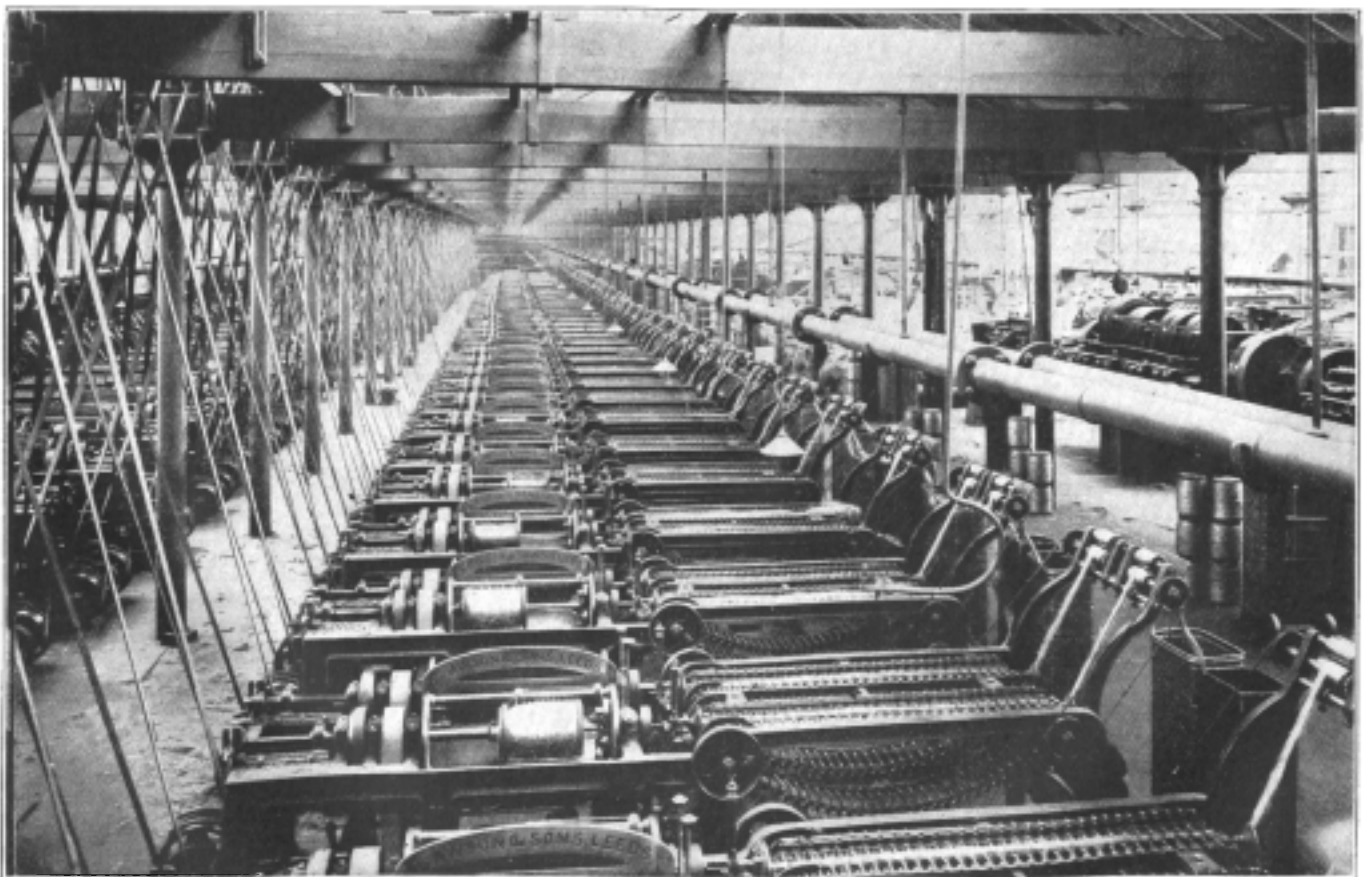

FIG. 15.—BINDER TWINE SPINNING, CONNSWATER MILL.

ROPE AND ROPE-MAKING

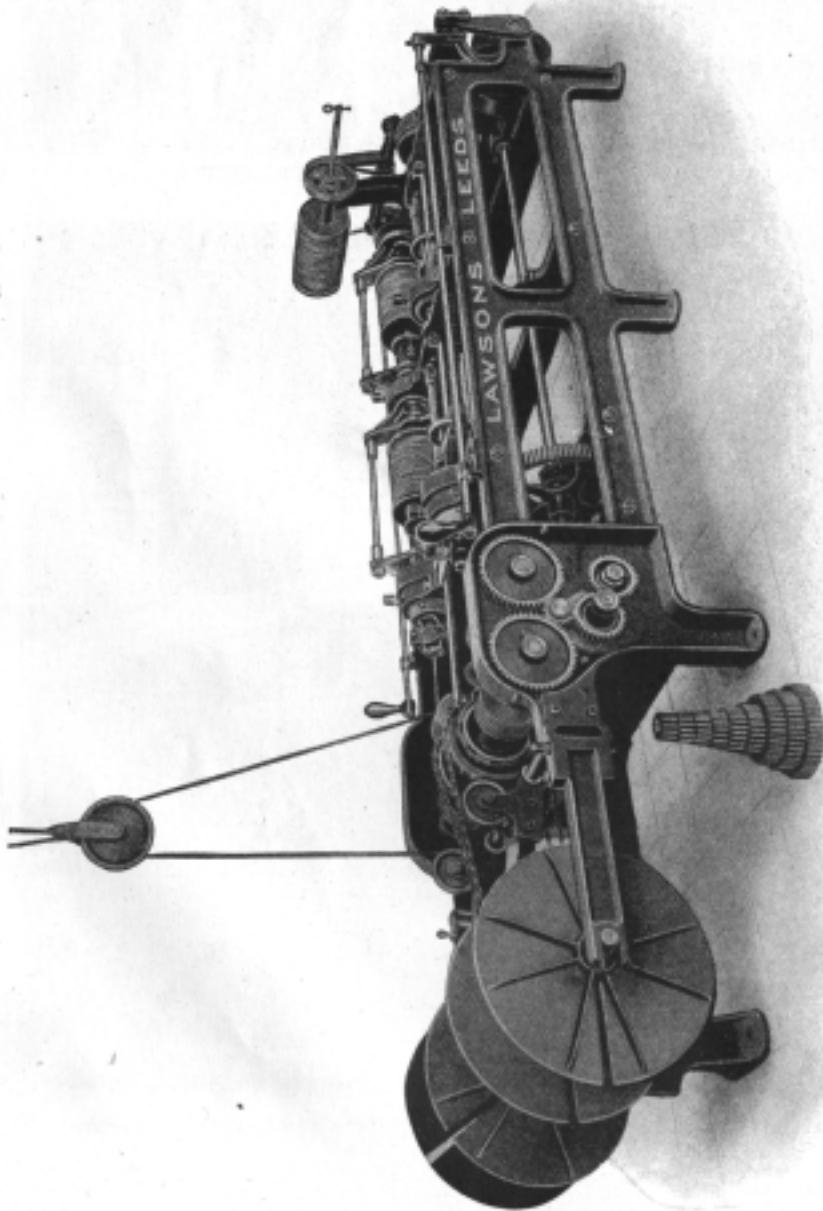

FIG. 16.—HASKELL-DAWES HORIZONTAL ROPE MACHINE.

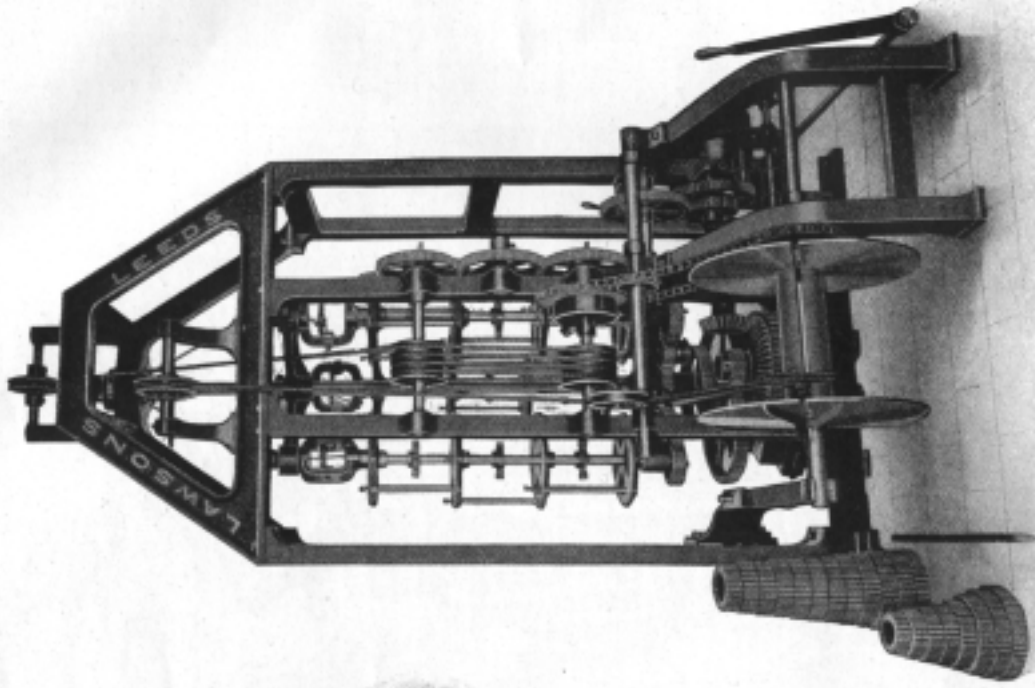
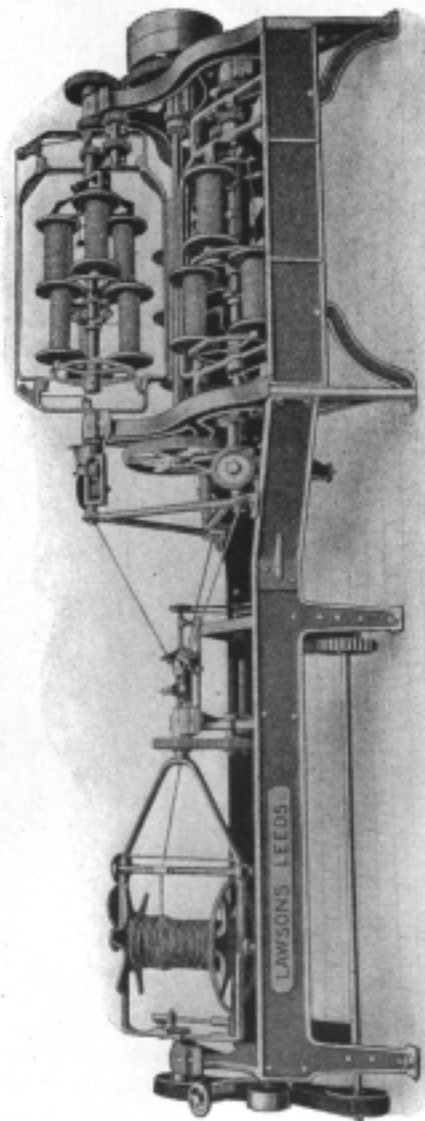

FIG. 18.—HASKELL-DAWES VERTICAL ROPE MACHINE.





the continuous system is mostly used; here the rope is wound round and round over driver and driven, and, except in rare cases, is joined only at one place. Although the system has the great advantage of the minimum number of joinings, it requires tension pulleys to keep the ropes taut. It is also clear that when the rope breaks at any point the machinery must stand until the repair is completed.

**Wire Ropes.**—Although the manufacture of ropes is of ancient origin, the practice of making ropes from wire on a large scale is of comparatively recent date. Since 1874, however, great developments have taken place in the manufacture of ropes from different kinds of wire, and the uses to which they can be put have enormously increased. This is owing almost entirely to the introduction of flexible wire ropes which were invented about this time by Messrs Bullivant & Co. Ltd., of 72 Mark Lane, London, E.C. Prior to that date the uses at which wire ropes were put were limited to winding ropes for collieries and hauling, and to cases in which flexibility was not a great desideratum. The introduction of flexibility, however, made possible the use of wire rope for ships' hawsers and rigging, for cranes, derricks and other purposes for which hempen ropes were formerly employed—indeed it has almost entirely superseded hemp for marine uses. The reason is that it is much stronger for the same size than rope made from any other material, whilst for the same strength its size and weight are only about one-third that of hempen rope. Consequently, the required power may be obtained with a wire rope of comparatively small bulk.

Wire rope is specially suited for aerial ropeways which provide a means of conveying ore, metals, merchandise, &c., over ground where it would be difficult to arrange transport by ordinary means. Messrs Bullivant & Co. Ltd., to whom we are indebted for the table of strengths and other particulars, as well as for the sectional illustration of wire ropes, construct seven different systems of aerial ropeways:—

1. The endless running rope, with carriers hanging therefrom and moving with it through frictional contact.
2. An endless rope, with the carriers hanging therefrom and moving with it, being rigidly fixed in position on the rope.
3. The fixed rope, in which the carriers are drawn along and hang from a fixed rope which acts also as a rail, returning on a parallel rope.
4. The single fixed rope, in which one carrier, hanging from a fixed rope, is drawn to and fro by means of an endless hauling rope.
5. The use of two fixed ropes with an endless hauling rope, in which one carrier travels in one direction, while the other travels on a parallel rope in the opposite direction. This is a serviceable type of ropeway, capable of being used over extremely long spans, and of carrying loads up to 5 tons.
6. The use of one fixed rope placed on an incline, on which the carriers (uncontrolled by hauling ropes) with their suspended loads are allowed to run down at a high speed. This is generally called a "shoot."
7. Bullivant's system of aerial ropeway for raising, lowering, and transporting heavy loads, by means of which a load can be hoisted, traversed in either direction and deposited at one operation.

The flexibility of a wire rope depends upon the number of wires of which it is formed; consequently the use to which a rope is to be put will partly determine the number of wires used in its construction. In some cases nearly 400 individual wires are employed in making one rope. Fig. 8 shows in section ten different types of construction, the particulars of which appear below:—

1. Laid rope made of 6 strands of 7 wires each. This is the class of rope most frequently used for hauling ropes where the size of the barrel and sheave will permit; it is also the make of rope in general use for standing rigging, and is such as is required by Lloyd's regulations.
2. Hauling rope made of 6 strands, each strand being of 7 wires covering 7 smaller ones.
3. Hauling rope made of 6 strands, each of 8 wires covering 7 smaller ones.
4. Hauling rope made of 6 strands, each of 10 wires covering 7 smaller ones.
5. Formed rope made of 6 strands of 19 wires each. In larger sizes this make of rope is used for standing rigging on vessels. In smaller sizes it is sometimes used for running rigging, and it is the usual make of rope for trawl warps.
6. Flexible steel wire rope, made of 6 strands each of 12 wires, with hemp heart and hemp centre in each strand. This is the usual make of flexible steel wire rope,  $4\frac{1}{2}$  in. in circumference and smaller; used for hawsers, running lifts, hoists, &c.
7. Extra flexible steel wire rope made of 6 strands each of 24 wires.
8. Special extra flexible steel wire rope made of 6 strands each of 37 wires.

9. Special extra flexible steel wire rope made of 6 strands each of 61 wires. This is the make of rope usually adopted for large ropes—say over 10 in. in circumference—which are largely used for slipway and salvage purposes.
10. Cable-laid rope. This is an obsolete form of rope, which is composed of six complete ropes twisted together.

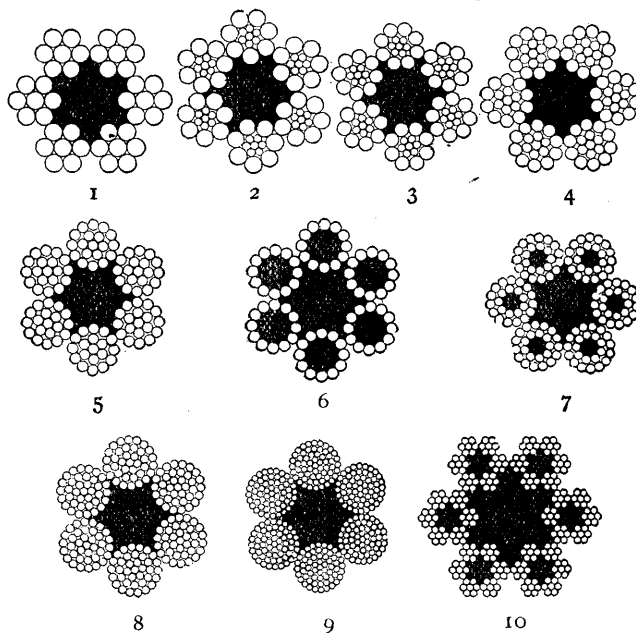

FIG. 8.

The following table supplies particulars about wire ropes which are used for general hauling purposes:—

Circumference.	Diameter.	Breaking Strain in Tons.				Approximate Weight per Fathom.
		"Crucible" Steel.	Best Selected Improved "Crucible" Steel.	Best Selected "Mild Plough" Steel.	Best Selected "Extra Plough" Steel.	
$1\frac{1}{4}$ in.	$1\frac{1}{8}$ in.	4 $\frac{1}{2}$	4 $\frac{3}{4}$	5 $\frac{1}{4}$	5 $\frac{3}{4}$	1 $\frac{3}{4}$ lb
$1\frac{1}{2}$ "	$1\frac{1}{4}$ "	6	6	7 $\frac{1}{4}$	7 $\frac{3}{4}$	2 $\frac{1}{4}$ "
1 "	$1\frac{1}{8}$ "	8 $\frac{1}{4}$	8 $\frac{3}{4}$	9 $\frac{3}{4}$	10 $\frac{1}{2}$	3 $\frac{1}{4}$ "
2 "	$1\frac{1}{4}$ "	11	11	12 $\frac{1}{2}$	14 $\frac{1}{4}$	4 "
$2\frac{1}{4}$ "	$1\frac{3}{8}$ "	14 $\frac{1}{4}$	15	16 $\frac{1}{2}$	18	5 $\frac{1}{4}$ "
2 "	$1\frac{1}{2}$ "	17 $\frac{1}{2}$	18 $\frac{1}{4}$	20	22 $\frac{1}{2}$	6 $\frac{1}{4}$ "
2 $\frac{1}{2}$ "	$1\frac{5}{8}$ "	21	22 $\frac{1}{2}$	24 $\frac{1}{4}$	27 $\frac{1}{4}$	7 $\frac{1}{2}$ "
3 "	$1\frac{3}{4}$ "	24	26 $\frac{1}{2}$	29	31 $\frac{3}{4}$	9 "
$3\frac{1}{4}$ "	1 "	29 $\frac{3}{4}$	31 $\frac{3}{4}$	35	38	10 $\frac{1}{2}$ "
$3\frac{1}{2}$ "	$1\frac{1}{8}$ "	34 $\frac{1}{2}$	36 $\frac{1}{4}$	40 $\frac{1}{4}$	44 $\frac{1}{4}$	13 "
$3\frac{3}{4}$ "	$1\frac{1}{4}$ "	39 $\frac{3}{4}$	42	46	50 $\frac{3}{4}$	14 $\frac{1}{2}$ "
4 "	$1\frac{3}{8}$ "	45 $\frac{1}{2}$	48 $\frac{1}{2}$	53	58	16 $\frac{1}{2}$ "
$4\frac{1}{4}$ "	$1\frac{1}{2}$ "	52 $\frac{1}{2}$	56	61 $\frac{1}{2}$	67	17 $\frac{3}{4}$ "
$4\frac{1}{2}$ "	$1\frac{5}{8}$ "	57 $\frac{1}{2}$	61	67	73	20 "
$4\frac{3}{4}$ "	$1\frac{3}{4}$ "	65	69	76	83	22 "
5 "	$1\frac{7}{8}$ "	72	76	83	92	25 "

The diameter of drums and sheaves should be about thirty times the circumference of the rope.

For shaft winding at high speed one-tenth of the breaking strain of a rope is sometimes taken as a fair working load. For inclines, the proportion of load to breaking strain varies according to gradient conditions, and friction should be allowed for.

The first requisite in the manufacture of wire ropes is the selection and blending of the different iron ores. The different processes through which the metal passes, and the hammering and drawing into rods, require great experience, and give to it the peculiar properties that are essential for the finished article. The same remarks apply to the annealing and hardening processes, during which the rods are drawn through dies to the required gauge. The wire is now subjected to special processes of galvanizing in order to make it proof against atmospheric and other influences. Afterwards it is wound on bobbins of suitable size, a definite number of which are mounted on the forks or frames of the stranding machine. These forks are swung or pivoted between disks, which are keyed on a hollow main shaft, through which the wires or other material

intended for the core pass. This core is of such a size that the aggregate number of wires that are mounted in the machine exactly cover it in a spiral direction.

All the wires, including the centre core, are passed through their individual hollow spindles, then led to the nose or head of the machine, and finally passed through a stationary compression block to draw-off wheels. The speed of these wheels is regulated in proportion to the speed of the machine by means of suitable gearing. During the revolutions of the machine each bobbin and fork is kept in a vertical position, and floats thus, by means of an eccentric ring behind the back disk. This ring is connected to the spindles of the bobbin forks by means of small cranks, thus preventing any torsional movement that would otherwise be imparted to the individual wires.

Each bobbin is controlled by a brake which acts as a tensioning device so that equal strain can be applied to each, allowing the wires to unwind uniformly. The finished strands are wound in turn upon large bobbins, and mounted in the flyers or disks of the rope closing machine. These machines are similar in design to the stranding machine, but are naturally much heavier in construction, and therefore revolve at a proportionate speed. The speed of the machines varies according to the weight of material, the size of the strands and the construction of the finished rope. The modern machine, or the type most generally used, makes about fifty revolutions per minute, whilst three times this speed is often obtained when spinning the strands.

The rapid strides made by electricity have furnished another large branch of what may be termed wire rope manufacture. The ropes used for electrical purposes are almost invariably termed cables, and there are many different kinds and sizes of them. The wire must necessarily possess good conducting power, and be comparatively cheap. Up to the present copper has proved to be the chief material possessing these two important properties in combination; hence it is the metal *par excellence* for electrical conduction. Aluminium and alloys have been tried with varying degrees of success.

The conductor itself consists of a strand of soft copper wires, around which the dielectric or non-conducting material is placed. The methods of forming the strands do not differ essentially from those described above. The dielectric is usually paper, spun jute fibre, vulcanized india-rubber or vulcanized bitumen. If the first two dielectrics are used, a lead sheath is necessary to enclose the insulated strand and so exclude moisture; if the cable is likely to get damaged, it is further enclosed by steel tapes or steel wires, and finally covered with yarn or braid. Vulcanized bitumen is not only a dielectric, but is also absolutely impervious to moisture. Hence in many instances where paper or fibre is employed as the principal dielectric, a sheath of vulcanized bitumen is used instead of lead to exclude moisture. Cables are also made with a single central stand of copper wires in addition to one or more concentric layers of copper wires, the layers being separated by some dielectric material; or there may be two or more strands, separately insulated, and more or less elaborately clothed with the above-mentioned substances.

(T. Wo.)