

Dec. 6, 1949

A. W. GAGE ET AL

2,490,589

SHUTTLE CONTROL MECHANISM FOR NARROW WARE LOOMS

Filed April 26, 1947

2 Sheets-Sheet 1

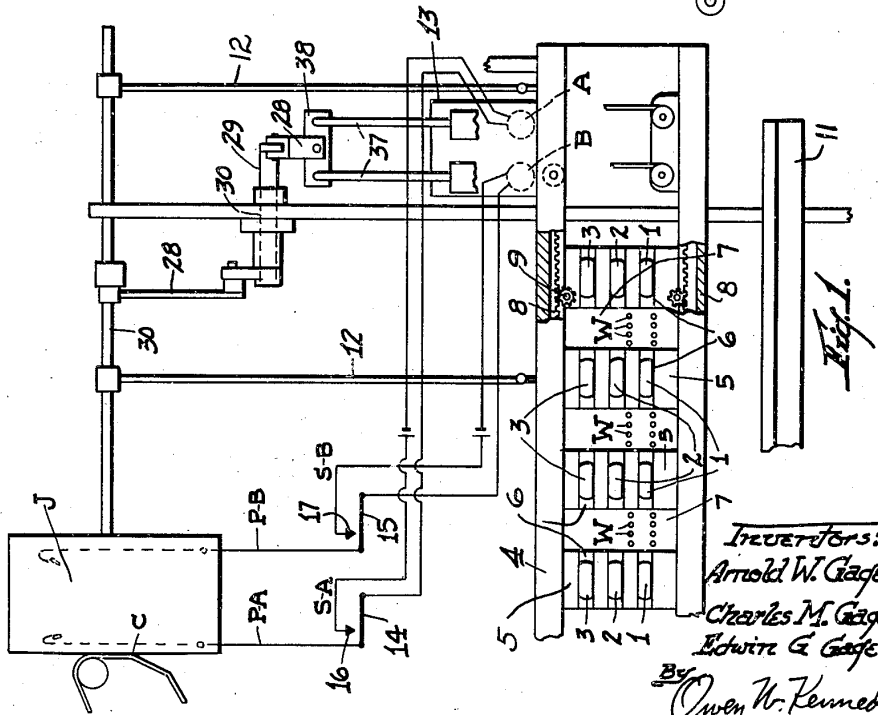
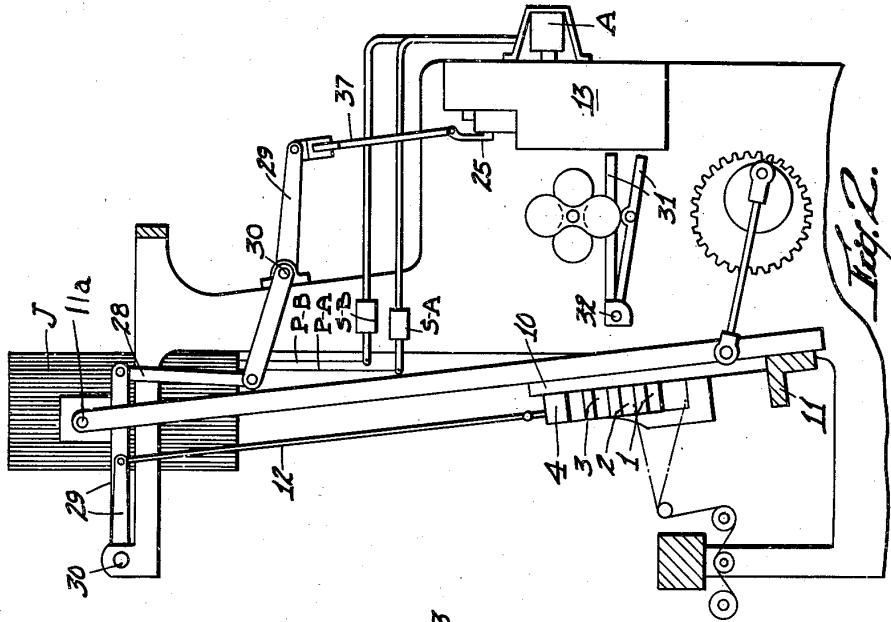

INVENTORS:
Arnold W. Gage
Charles M. Gage
Edwin G. Gage
By Owen W. Kennedy
ATTORNEY

Dec. 6, 1949

A. W. GAGE ET AL

2,490,589

SHUTTLE CONTROL MECHANISM FOR NARROW WARE LOOMS

Filed April 26, 1947

2 Sheets-Sheet 2

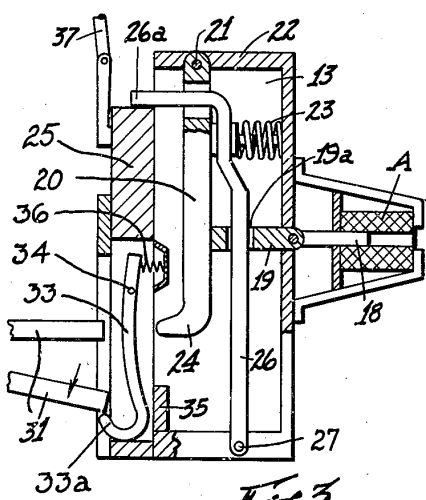

Fig. 3.

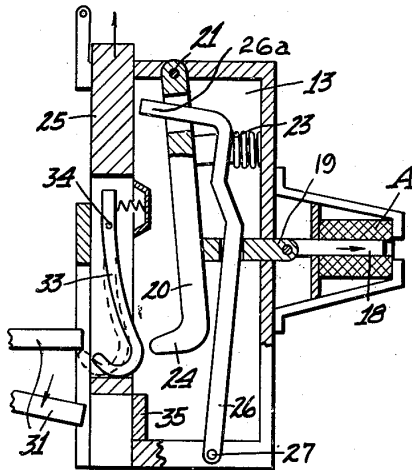

Fig. 4.

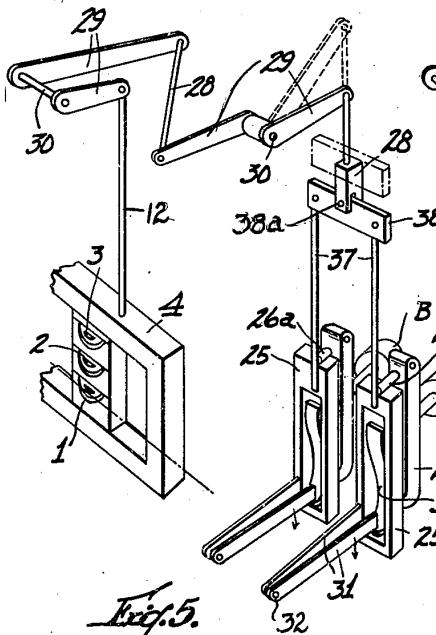

Fig. 5.

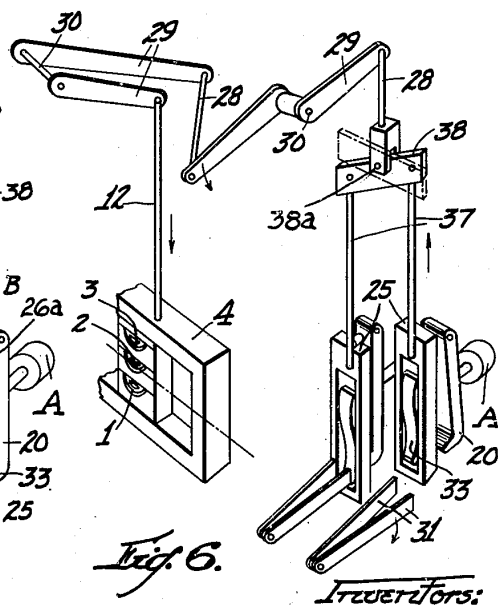

Fig. 6.

Inventors:

Arnold W. Gage
Charles M. Gage
Edward G. Gage
29 Owen W. Kennedy
ATTORNEYS

UNITED STATES PATENT OFFICE

2,490,589

SHUTTLE CONTROL MECHANISM FOR NARROW WARE LOOMS

Arnold W. Gage, Charles M. Gage, and Edwin G.
Gage, Clinton, Mass.

Application April 26, 1947, Serial No. 744,220

3 Claims. (Cl. 139—137)

1

The present invention relates to narrow fabric, or narrow ware, looms of the type that are adapted to weave a number of separate tapes or ribbons in accordance with a pattern, as when weaving a large number of similar labels that are connected together in each tape, with each label having a definite design. Narrow ware looms of this character provide a large number of shuttles that are arranged in horizontal rows, or banks, for movement back and forth on a batten structure with respect to a series of warp sheds passing through the batten.

When a narrow ware loom is operated to weave a design, several horizontal banks of shuttles are arranged on the batten in superposed relation, with the filling of the shuttles in the separate banks being of different color, or character, and provision is made for moving the entire batten structure up or down to bring some particular shuttle bank to the same elevation as the series of warp sheds. The shifting of the batten structure therefore selects which bank of shuttles will be driven through the warp sheds and the position of the batten structure is automatically determined by the functioning of a pattern control mechanism of the jacquard type. In pattern controlled narrow ware looms as heretofore constructed, it has been customary to transmit indications from the pattern chain through a complicated mechanical arrangement of shafts and linkages extending from the jacquard mechanism to one end of the loom where the control box which determines the position of the batten is located. Since narrow ware looms are usually over 20 feet in length, any mechanical arrangement for transmitting pattern changes from the jacquard is subjected to heavy strains and the resulting wear of the connected parts often causes faulty operation and even breakages or jams in the shuttle driving mechanism on the batten structure.

The object of the present invention is to provide an improved shuttle control mechanism for narrow ware looms wherein indications of the pattern are transmitted electrically to solenoids within the control box, the essential operating parts of which have been rearranged so as to provide for more accurate and positive operation of the associated mechanism for determining the position of the batten structure. As a result of the employment of our improved electrical shuttle control mechanism, breakages and shutdowns are reduced to a minimum, as compared to the operation of looms equipped with

2

purely mechanical elements for transmitting pattern change indications.

A further object of the invention is to provide a shuttle control mechanism which is not only simple in construction and reliable in operation, as noted above, but which is also capable of being applied to existing looms by an easily accomplished removal and replacement of readily accessible parts in the control boxes of such existing looms. The above and other advantageous features of the invention will hereinafter more fully appear from the following description considered in connection with the accompanying drawings in which:

Fig. 1 is a view in front elevation of a portion of a narrow ware loom including the batten structure and its associated parts of the shuttle control mechanism.

Fig. 2 is a view in end elevation of the parts shown in Fig. 1, as viewed from the right.

Fig. 3 is an end view partially in section showing the application of our improved solenoid actuated mechanism to the control box of Fig. 1, on an enlarged scale.

Fig. 4 is a view similar to Fig. 3 showing the position of parts when one solenoid is energized.

Fig. 5 is a fragmentary showing, partially in perspective, of the control mechanism of Fig. 3, with its connections to the mechanism for selectively determining the position of the batten, shown with the loom frame removed.

Fig. 6 is a view of the parts shown in Fig. 5 with one solenoid energized to change the position of the batten.

Referring first to Figs. 1 and 2, a portion of the front of a narrow ware loom is shown in which a number of rows or banks of shuttles 1, 2, and 3 are arranged in superposed relation across a batten 4 that extends the full width of the loom. The batten 4 provides spaced blocks 5 whose races 6 receive the shuttles 1, 2, and 3 as any selected bank of shuttles is moved back and forth through the warp sheds W that pass through spaces 7 in the batten 4 between blocks 5.

The shuttles are adapted to be driven by racks 8 through pinions 9 in the blocks 5 in cooperation with suitable driving belts and pulleys, only partially shown, when any particular shuttle bank is at the same elevation as the warp sheds W. In the position of parts shown in Fig. 1, the lowermost bank of shuttles 1 which carries the ground filling is at the level of the warp sheds W, so that driving of the shuttles 1 will cause their

3

filling to be laid into the warp sheds W as long as the batten 4 remains in this position.

As best shown in Fig. 2 the batten 4 is movable vertically on guides 10 provided by the lay 11 which is pivoted at 11a to swing back and forth in the usual manner and beat up the weft threads after they are laid in the warp sheds W by selective operation of the shuttles 1, 2, or 3, in the several banks. The position of the batten 4 on the lay 11 with reference to the level of the warp sheds W determines which row or bank of shuttles 1, 2, or 3 will be driven through the warp sheds, so that a design will be woven in the narrow fabrics or tapes in accordance with the differences in color or character of the fillings in the shuttles. The batten 4 is vertically movable by rods 12 connected to suitable mechanism, hereinafter described, for automatically determining the vertical position of the batten in accordance with the operation of a pattern mechanism of the jacquard type. This jacquard mechanism is indicated at J in Fig. 1 as being located about the middle of the loom and the present invention is concerned with the manner in which filling change indications of the jacquard pattern are transmitted to a control box at one side of the loom, this control box being generally indicated by the reference character 13.

Each warp shed W is under the control of the jacquard mechanism J which is of usual construction and provides a set of cards C for determining the pattern that is to be woven into the labels. In addition to controlling the warps W, the jacquard mechanism J provides extra needles under the control of the cards C that are adapted to actuate hooks within the mechanism. These hooks are adapted to be moved upwardly upon receiving an indication from a card needle to cause a change to occur in the selection of the character or color of the filling in shuttles 1, 2, or 3 for passage through the warp sheds W.

In previous shuttle control mechanisms, the movements of the jacquard hooks have been transmitted through a complicated arrangement of links and shafts to the control box 13 at the side of the loom. This control box has also provided a complicated arrangement of cams and gears responsive to movement, as transmitted from the jacquard needles so as to determine which one of the shuttles 1, 2, or 3 shall be passed through the warps when the sheds are next opened. The object of the present invention is to replace the old mechanical arrangement by an electrical control of an extremely simple and effective character that will perform all of the essential functions of the shuttle control in cooperation with the jacquard mechanism J.

In the electrical control, switches S—A and S—B are provided, with the movable contact arms 14 and 15 of the switches being connected to the hooks by pulls P—A and P—B, respectively. Each switch also provides a stationary contact 16 or 17, with the movable switch arms and stationary contacts 14, 16, and 15, 17 connected to solenoids A and B of the shuttle control. As shown, closure of the switch S—A by movement of the pull P—A will energize the solenoid A, while closure of the switch S—B by movement of the pull P—B will energize the solenoid B. The connection to the jacquard hooks is indicated in dotted lines in Fig. 1.

As indicated in Fig. 1, the shuttles 1 which carry the ground filling will operate on each opening of the warp sheds so long as the solenoids A and B are not energized by closure of

4

either switch S—A or S—B. However, if either solenoid A or B is energized, alone, by closure of its switch, in response to an indication from a card C, the shuttles 2 will be moved through the sheds. Energization of both solenoids A and B, together, in response to a dual card indication serves to bring the shuttles 3 in position for movement through the warp sheds, so that a design will be woven in each tape in accordance with differences in the fillings, as determined by the pattern.

Referring now to Fig. 3, there is shown an arrangement whereby the solenoids A and B are adapted to select which of the shuttles 1, 2, or 3 are to be moved through the warp sheds W. It is to be understood that the arrangement of parts shown in Fig. 3 for the solenoid A is duplicated for the solenoid B, with the electrical control mechanism cooperating with existing batten operating parts of the loom that are shown only partially in Fig. 5.

The solenoid A provides a plunger 18 that is pivotally connected to a link 19 which is in turn connected to a hammer 20. The upper end of the hammer 20 is pivoted at 21 to a frame 22 forming part of the control box 13 which is attached to one end of the loom and serves to support the other related parts of the control mechanism. The relation of the frame 22 with respect to the operating mechanism for the batten 4 is shown in perspective in Fig. 5, and on a reduced scale in Fig. 2.

The hammer 20 is engaged by a spring 23 which tends to hold a lug 24 on the lower end of the hammer in engagement with one side of a slide 25 that is vertically movable in the frame 22. When the hammer 20 is in the position of Fig. 3 a locking hook 26 pivoted at 27 has its upper end 26a projecting over the upper end of the slide 25. Therefore, with the hook 26 in this position, the slide 25 is not permitted to move upwardly under the pull of a motion transmitting mechanism consisting of a series of links 28 and associated levers 29, turnable with shafts 30 that extend parallel to the batten 4, as best shown in Figs. 1 and 2. This mechanism thus serves to connect the slides 25 to the batten control rods 12 that determine the horizontal position of the several banks of shuttles 1, 2 and 3 with respect to warp sheds W. In the general showing of Fig. 5, both slides 25 are shown as being held down by the ends 26a of the pair of locking hooks 26 that are under the control of the solenoids A and B.

In this basic position of parts the solenoids A and B are deenergized, so that the ground filling shuttles 1 will operate in unison through the sheds all the way across the batten 4, back and forth movement being imparted to the shuttles by any suitable mechanism for moving the racks 8. Still referring to Fig. 5, each slide 25 is moved to its lower position by pairs of treadles 31 pivoted at 32, with the treadles 31 being given up and down motion as indicated by the arrows through any suitable mechanism operating in timed relation with the drive shaft of the loom, see Fig. 2. In its downward movement the end of each treadle 31 is adapted to engage a slide hook 33 pivoted at 34 on the slide 25 as shown in Fig. 3. In the lowermost position of the slide 25 the end of each hook 33 is forced outwardly by a stop 35 fixed on the frame, although as soon as the slide 25 starts to move upwardly, a spring 36 will turn the hook 33 about its pivot

34 to withdraw the end 33a of the hook from engagement by its treadle 21, see Fig. 4.

As best shown in Fig. 3, the locking hook 26 passes through a slot 19a in the link 19 which connects the hammer 20 to the solenoid plunger 18. Therefore, when the solenoid A is energized by closure of the switch contacts 14 and 16, in response to an indication for a shuttle change from a card C, the parts will be moved into the position of Fig. 4. In this position, the hammer 20 has been swung to the right about its pivot 21 thereby causing the link 19 also to swing the hook 26 to the right to remove its end 26a from its previous position over the top of the slide 25. Therefore, the slide 25 can move upwardly before the next beat of the batten 4 so as to permit the batten control rods 12 to move downwardly into the position of Fig. 6, wherein the middle shuttles 2 have been positioned for movement through the warp sheds W. In the raised position of the slide 25, it is to be noted that the hook 33 is inside the slide so that the next downward movement of the treadle 31 will not pull the slide down as long as the solenoid A is energized. However, should the switch S—A be opened in response to the pattern of the card C, the spring 23 will move the hammer 20 to the left, as viewed in Fig. 4, thereby causing the lug 24 on the hammer to press the hook 33 into the dotted line position, so that the next downward beat of either treadle 31 will return the slide 25 to the position of Fig. 3, where it is again locked by the end portion of the hook 26a until another shuttle change is indicated.

As previously noted, energization of either solenoid A or B will bring the middle shuttles 2 into weaving position and this selective operation is shown in Figs. 5 and 6. It is to be noted that the rods 37 which operate the slides 25 are connected at their upper ends to a cross lever 38 pivoted at its middle to the first link 28 of the previously described motion transmitting mechanism that is connected to the batten control rods 12 through the series of levers 29 and shafts 35, and the interposed second link 28. Assuming that the solenoid B is deenergized, so as to hold its slide 25 down, the upward movement of the other slide 25 under the control of solenoid A, will turn the cross lever 38 about its left-hand end which is held fixed, as shown in Fig. 6. This limited movement of the lever 38 permits the batten control rods 12 to move downwardly only far enough to position the middle bank shuttles 2 for movement through the warp sheds W, as indicated by dot and dash line.

Obviously, should the solenoid B become energized through closure of the switch S—B while the switch S—A is open, the lever 38 will be swung into the dotted line position of Fig. 6, wherein the lever 38 turns about the fixed end of the right-hand slide rod 37. Should both solenoids A and B be energized together, under the control of a card C, then both slides 25 are permitted to move upwardly into the position shown in dotted lines in Fig. 5 from which it is obvious that the middle point of the lever 38 can rise higher than as shown in Fig. 6 to permit the batten control rods 12 to move downwardly far enough to position the top bank of shuttles 3 for movement in the warp sheds.

As previously pointed out, the treadles 31 which operate in pairs to move the slides 25 down are driven from the main shaft of the loom, so that one treadle 31 will move downwardly to engage a hook 33 in advance of each beat of

the batten 4 into the warp sheds W. Therefore, assuming that both solenoids A and B are deenergized, both slides 25 will remain down in the position of Fig. 5 by reason of the fact that the locking hooks 26 will hold the slides down against the upward pull of the slide rods 37 as first one and then the other of the treadles 31 are raised. Therefore, as long as the solenoids A and B remain deenergized, with the switches S—A and S—B open, the batten 4 will remain in the position of Fig. 1 with the ground filling in the lower bank of shuttles 1 being woven in the several tapes.

Assuming now that a filling change is indicated by a pattern card C to close the switch S—A and energize the solenoid A, turning movement of the hook 26 from the position of Fig. 3 into the position of Fig. 4 will permit the associated slide 25 to move upwardly into the position of Fig. 6 in response to upward pull on the rod 37 by the weight of the batten 4. When this occurs, the resulting upward movement of the rod 37 acting through the cross lever 38 and the connections 28, 29 and 30 leading to the batten control rods 12, will permit the batten 4 to fall into the position of Fig. 6 to bring the middle bank of shuttles 2 to the horizontal level of the then open warp sheds W. The entire bank of shuttles 2 will then be driven through the sheds to lay a new type of filling that differs in color or character from the ground filling previously laid by the shuttles 1. This laying of the filling by the shuttles 2 is followed by beating up of the fillings as the warp sheds are closed.

Assuming that the pattern card C is laid out to cause the laying of successive fillings from the shuttles 2, the switch S—A will remain closed and the solenoid A will remain energized. Should this occur, it is evident that the slide hook 33 will remain in the full line position of Fig. 4 so that the next downward beat of the associated treadle 31 will not pull the slide 25 downwardly. As a result, the batten 4 will remain in the position of Fig. 6, so that the middle bank of shuttles 2 will again lay the same filling in the open warp sheds W.

If, however, the pattern card C calls for the laying of a ground filling from shuttles 1 to succeed the laying of fillings from shuttles 2, the resulting deenergization of solenoid A or B will cause the spring 23 to move the hammer 20 from the position of Fig. 4 back to the position of Fig. 3. Assuming that the slide 25 is then raised as shown in Fig. 4, the lug 24 at the end of the hammer 20 will move the slide hook 33 into the dotted line position of Fig. 4 wherein the end 33a of the hook will be engaged by the treadle 31 on its next downward beat to carry the slide 25 downwardly to the position of Fig. 3. As the slide 25 reaches its lowermost position, the locking hook 26 resumes its former position with its end portion 26a in position over the top of the slide 25 to prevent upward movement of the slide when either treadle 31 moves upwardly.

When the pattern card C calls for a filling of the type in the shuttles 3, both switches S—A and S—B are closed simultaneously to energize both solenoids A and B. When this occurs, the operations previously described with reference to Figs. 3 and 4 take place with respect to both hammers 20 so that withdrawal of both locking hooks 26 permits both slides 25 to move upwardly. Simultaneous upward movement of both slide rods 37 then causes the cross lever 38 to assume the dotted line position of Fig. 5 wherein

the pivot 38a of the cross lever occupies a position above the position of the pivot in Fig. 6 wherein only one slide is up. The increased amplitude of movement of the connections 28, 29 and 30 leading to the batten rods 12 permits the batten 4 to move downward a distance sufficient to bring the top bank of shuttles 3 into the horizontal plane of the open warp sheds W. The filling from the shuttles 3 will then be laid into the fabric of the tapes for one or more beats of the batten, in accordance with the operation of the switches S—A and S—B to simultaneously energize or deenergize the solenoids A and B. Upon deenergization of both solenoids A and B, movement of the hooks 33 into the dotted line position of Fig. 4 will cause both slides 25 to be pulled downwardly by the treadles 31 to move the batten 4 upwardly into the position of Fig. 5, wherein the bank of shuttles 1 carrying the ground filling will be laid into the warp sheds for one or more beats until the next filling change is indicated by the card C of the jacquard mechanism J.

From the foregoing, it is apparent that by the present invention there is provided an improved shuttle control mechanism for looms of the narrow ware type, wherein pattern indications for filling changes are transmitted electrically to the control box, so as to cause accurate and positive actuation of the associated mechanism for determining the position of the batten. As a result of the employment of our improved shuttle control mechanism, breakages and shutdowns are reduced to a minimum, and as previously pointed out, the control mechanism of our invention is capable of being applied to existing looms by an easily accomplished removal of existing parts of a control box and their replacement by the new parts.

We claim:

1. A shuttle control mechanism for narrow ware looms comprising in combination, a series of warp sheds, a batten structure carrying banks of shuttles in superposed relation, said batten structure being movable, as a unit, to position any one of said shuttle banks at the elevation of the warp sheds, a control mechanism at one side of the loom comprising a vertically movable slide connected to the batten structure so that the weight of same tends to move the slide upwardly, accompanied by downward movement of the batten, a latch for holding down said slide and a solenoid for operating said latch to permit upward movement of said slide upon energization of said solenoid.

2. A shuttle control mechanism for narrow

ware looms comprising in combination, a series of warp sheds, a batten structure carrying banks of shuttles in superposed relation, said batten structure being movable, as a unit, to position any one of said shuttle banks at the elevation of the warp sheds, a control mechanism at one side of the loom comprising a vertically movable slide connected to the batten structure so that the weight of same tends to move the slide upwardly, accompanied by downward movement of the batten, a latch for holding down said slide, a solenoid for operating said latch, a pattern control mechanism for indicating a change in the fillings carried by said shuttles, and electrical connections extending between said solenoid and said pattern control for energizing said solenoid in response to a filling change indication, to operate said latch and permit upward movement of said slide to position a different bank of shuttles at the elevation of the warp sheds, as the batten structure moves downwardly.

3. A shuttle control mechanism for narrow ware looms comprising in combination, a series of warp sheds, a batten structure carrying banks of shuttles in superposed relation, said batten structure being movable, as a unit, to position any one of said shuttle banks at the elevation of the warp sheds, a control mechanism at one side of the loom comprising a vertically movable slide connected to the batten structure so that the weight of same tends to move the slide upwardly, accompanied by downward movement of the batten, a latch for holding down said slide, a treadle for moving down the slide between beats of the batten structure into a position in which said slide is held by the latch and a solenoid for operating said latch to permit upward movement of said slide upon energization of said solenoid, accompanied by downward movement of the batten to position a selected bank of shuttles at the elevation of the warp sheds.

ARNOLD W. GAGE.
CHARLES M. GAGE.
EDWIN G. GAGE.

REFERENCES CITED

The following references are of record in the file of this patent:

UNITED STATES PATENTS

Number	Name	Date
786,237	Schaum	Mar. 28, 1905
2,106,504	Lindquist	Jan. 25, 1938
2,132,758	Preston	Oct. 11, 1938