

# Posselt's Textile Journal

*A Monthly Journal of the Textile Industries*

PUBLISHED MONTHLY BY

E. A. POSSELT, 2028 BERKS STREET,  
PHILADELPHIA, PA.

#### SUBSCRIPTION RATES:

United States and Mexico, \$2.00 per year.

Canada, \$2.50 per year.

Other countries in the Postal Union, \$3.00 per year.

Single Copies, 25 cents.

This Journal is published on the tenth of each month.

Postage prepaid by the Publisher.

Subscriptions begin with the number following the date on which the subscription is received at this office.

In writing about subscriptions, always give your full name and address.

When writing for changes in address, always give the old address as well as the new address to which copies are to be sent.

Money should not be paid to agents or solicitors unless they can show authority from this office. This Journal cannot be responsible for money paid to unauthorized persons.

Subscriptions are payable in advance. Money can be sent by check, draft, money order or in registered letter. Make all drafts, checks, money orders, etc., payable to E. A. POSSELT, Publisher, 2028 Berks Street, Philadelphia, Pa.

#### ADVERTISING RATES ON A CAUTION.

COPY FOR ADVERTISEMENTS must reach this office not later than the 25th of month preceding date of issue, to insure proper attention.

ALL COMMUNICATIONS WILL BE CONSIDERED AS CONFIDENTIAL.

Letters to receive attention must be accompanied by the signature of the sender, but this will not be published unless so requested.

We will always be glad to receive articles of a practical nature relating to the textile industries, and will publish such as are available.

EUROPEAN AGENTS: Sampson Low Marston & Co., Ltd., 100 Southwark Street, London, S. E., England.

#### OBITUARY.

##### JOHN ROYLE, SR.

John Royle, Sr., founder of the well-known firm of John Royle & Sons, of Paterson, builders of Card stamping, Lacing and Repeating machinery, etc., died at his home in that city November 1, at the age of eighty-six.

The deceased was born in England, coming to this country with his people when eight years old. He first worked for six years in a cotton mill, from five in the morning until eight o'clock at night, receiving a salary of \$1 a week. In 1839 Mr. Royle entered the works of Rogers, Ketchum & Grosvenor as a machinist's apprentice, and it was here he learned his trade as a machinist, and where he afterwards held several important positions, devoting all his energy to perfecting the locomotives which were turned out by this Paterson plant. He worked so hard that his health broke down, which compelled him to remain idle for a period of two years.

When he regained his health he entered the employ

of the late John E. Van Winkle, who then conducted a large machine shop in the old Beaver Mill, and afterwards entered the shops of the Watson Machine Co., where for several years he supervised the construction of turbine water wheels. He remained there until 1860, when he started in business on his own account in a small shop on Water Street. The Civil War forced him to close his machine shop and he again entered the employ of the Watson Machine Co., and spent two years in building flax machinery. In 1863 he again opened a shop on Water Street, where he laid the foundation of the business which has since become the well-known firm of John Royle & Sons.

In 1875 Mr. John Royle, Jr. went into the business, and in 1879 Mr. Vernon Royle became identified with the firm. At this time it was felt that the Water Street shops were inadequate to take care of the growing business, and in 1881 the plant was moved to the Barnert mill. The firm soon outgrew these quarters and space was taken in the Watson Machine Co.'s mill. The business continued to grow, and in 1886 a tract of land was bought at Straight and Essex Streets, where their extensive buildings are now located.

Mr. Royle did much to build up the prosperity of Paterson, and was one of its most highly-esteemed citizens.

#### SILK FROM FIBRE TO FABRIC.

(Continued from page 132.)

##### Wild Silks.

##### (2) ANTHEREA YAMAMY.

This wild silk worm feeds on the leaves of the oak tree of Japan and where (according to *Sira-kawa & de Rosny*) he has been known since 1487, then discovered upon the island of *Fatsitsyo* and trans-

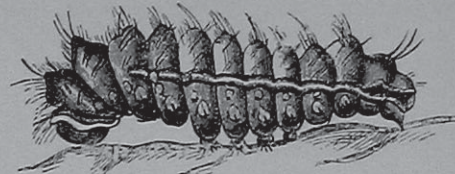

FIG. 13 ANTH. YAMAMY—LARVA.

planted to *Nippon*. His original home, however seems to have been China and where he has been met with in the mountain regions in a fully wild state. This is the reason why in Japan he is called *Yama-*



FIG. 14 ANTH. YAMAMY—COCOON.

*mayu* (silk worm of the mountains). This silk worm, in its method of living and breeding, closely resembles the *Bombyx mori*, and the silk obtained from it is of considerable value. In former times the product of

this silk worm was entirely reserved for the reigning house of Japan, the penalty found exporting eggs being death. In 1862 experiments were made to trans-

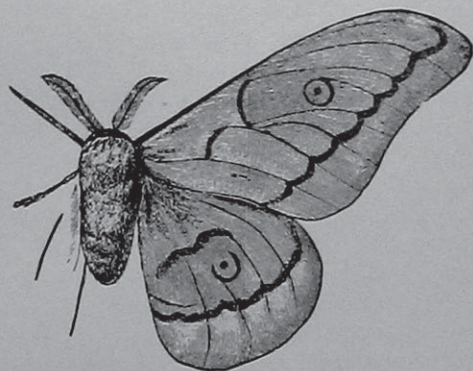

FIG. 15 ANTH. YAMAMY—MOTH.

plant this silk worm to Europe, India as well as here, crossing them with other breeds, however without lasting results. Japan raises the *Anth. Yamamy* in several

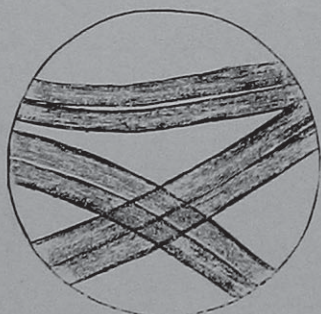

FIG. 16 ANTH. YAMAMY—FIBRE, ENLARGED.

districts, viz: Goshu, Tango, Etshigo, Koshu and Owari and very extensively in Sinschin, where several villages, known collectively as Matsukawagumi with Furumaya as its centre, depend entirely upon its raising.

The round, about 3 to 4 mm measuring egg of this worm has a brown color, which however does not belong to the egg proper, but is merely a covering for the latter, keeping the egg in a moist condition, a feature of advantage during breeding. This feature was the reason why for some time, although a mistake, the eggs, relieved from this covering were considered of no further value. Another characteristic point is that the young larva is already formed in the egg within 3 or 4 weeks after it is laid and in this condition passes without danger through the winter months. In connection with the *bombyx mori*, as well as other silk worms having only one generation per year, this forming of the larva in the egg does not take place until Spring.

The cocoon, oblong in shape, frequently covered with leaves, is either of a most beautiful golden or a faint green color and of a regular structure. Its average dimensions are 45-53 mm long, by 23-27 mm wide. The larger dimensions refer to those of the female gender and which weigh about 7 g and in some instances up to 8 g, whereas the cocoon of the true silk worm only weighs in an average about 3 g. 12 kg cocoons furnish 1 kg Grège and 1,000 cocoons

800 g raw silk. These cocoons are easily reeled, each cocoon resulting in about 800 m fibre, starting with a greenish yellow, becoming towards the inner part of the cocoon gradually whiter and somewhat thinner. The moth of the *Anth. Yamamy* is of a beautiful golden color with a white cross border and rose colored peacock eyes. In Japan the product of this silk worm is extensively used in combination with true silk in the manufacturing of some of the most exquisite figured specialties, but is little used outside that country, on account of the difficulties said fibre presents in dyeing, the same, it is thought in Europe, to be caused by artificial weighting. It is the silk which comes nearest to true silk, both from a technical as well as chemical point of view.

There are several other varieties of wild silk worms that feed on the leaves of the oak tree in Japan, but which do not belong to the specie *Yamamy*, they being *Anth. fentoni*, (a gray moth), *Anth. hazina* (a red moth), *Anth. calida* (a brown moth) and finally *Anth. marosa*.

(To be Continued)

#### THE TAKE-UP IN TWIST OF SILK.

James Chittick.

The thread of the raw silk of commerce is composed of several cocoon filaments reeled into a single strand. A considerable proportion of the filament emitted by the silk-worm is a sort of gum, called sericin, that is soluble in water, and, as it is necessary to float the cocoons in hot water, during the reeling, the filaments, as they unwind from the cocoons, are wet and sticky, and consequently adhere. Thus it will be seen that the raw silk thread, as it comes to us in the skein, is composed of several filaments, gummed together, and lying side by side.

In this condition it would be impossible to dye it, as the fibres would open up and get tangled and matted, so it is put through a twisting process called *throwing* to prepare it for the dyer. In this twisting, the silk undergoes a shortening in length and it is of this feature that I propose to speak.

The verb to *throw*, formerly *throw*, is an old English word, meaning to whirl, to spin, etc., and in this sense it is applied to the twisting, or so-called spinning, of silk.

Thrown silk may be made in *singles*, *tram*, or *organzine*.

The amount of silk thrown into singles is relatively very small, and most of what is so thrown goes into hard twist, for such goods as chiffons, etc.

The great bulk of all the silk consumed is thrown into organzine for warp purposes and into tram for filling.

Material for warp has to undergo a heavy strain in the weaving and has to withstand the friction of the harness, reed, and shuttle, in addition to the ordinary strain that occurs previously in the winding and warping processes. On this account a very well knit and homogeneous thread is necessary, and so the single threads of the raw silk are well twisted in one direction and then two or more of them are doubled

together and well twisted in the reverse direction, and thus a suitable warp yarn is produced. Silk when so processed is called *organzine* and nearly all organzine is thrown into two threads.

For filling purposes the silk has very little strain put on it in the mill, having only to be wound, quilled, and woven, and any twisting, beyond the little required to hold it in shape through the dyeing, is unnecessary. Being but slackly twisted the silk comes up bulkier, and more lofty, and consequently fills the fabric better.

When preparing the filling, therefore, the single threads are not twisted to any extent, but two or more of the raw silk threads are doubled together and then twisted only slackly in one direction, the product, so obtained, being called *tram*. In this country tram is usually made up of from two to six raw silk threads, the bulk of it being thrown into three, four, or five thread tram.

The question of the shortening due to twisting, is complicated by a variety of conditions, and which we will discuss.

Silk is a very elastic substance and when stretched reasonably, will fly back to its original length. Should it be greatly stretched, or should the stretch given it, be given time to set—as when left on bobbins for a period, it will not go back to where it was before the strain upon its ductility having permanently lengthened it, however leaving it, of course, with diminished elasticity.

When we are considering the change in length due to the twist, we must not confuse it, or intermix with it, the change that may be caused by the stretching.

If, after being soaked, the raw silk is wound while in a wet or damp condition—a very common but most improper method—it will stretch materially, though very irregularly, as all of the skeins, or parts of skeins, will not be equally damp. It can also be stretched by putting an extra heavy drag on the thread in the winding, doubling, etc., or by putting on heavy flyers in the spinning, or by running the machines at excessive speeds. Some silks are much more elastic than others and will stretch more. Furthermore, on damp and humid days the stretch will be greater than on a very dry day.

The determination, also, of the exact count, or average yardage per pound, of any lot of silk is extremely difficult, if not impossible, to arrive at, though the new Compound sizing test, introduced by the United States Silk Conditioning Company of New York, gives it more correctly than ever before.

These considerations are cited to show how next to impossible it is for any ordinary manufacturer to determine from his own experiments or practice, exactly what amount he should allow for the take-up in twist.

We must deal then with the results to be expected when silk is worked under average normal conditions.

On this basis only reasonable amounts of soap and oil should be added to the soaking water—say two or three per cent. of the weight of the silk; the silk, after soaking, should be dried and then allowed to re-

gain its natural moisture; the temperature and humidity of the rooms when the various processes are carried on should be normal; the speeds of the machinery, while fast, should not be excessive; the silk, if under much tension, should not be left unduly long on the bobbins, and we should also assume that the silk has an average amount of elasticity.

The coarser in size that the silk is, the greater the take-up will be for a given twist, and, as we cannot here deal with all the ramifications of the question, we will assume that the organzine is composed of two threads of 13/15 denier silk (and the great bulk of the organzine is), and that the tram is of an average of four threads and made of 13/15 denier silk, coarse.

Most American manufacturers have their organzine thrown with sixteen turns of twist per inch in the single thread and fourteen turns in the reverse twist, on the two-thread. They do not, however, get as strong a thread as when the twists are less nearly equal. For instance, if sixteen turns of twist were put into both, the single and the two-thread, it would be found, strange as it may seem, that after the reverse twisting was completed, all of the twist would have been taken out of the single threads and the advantage in strength, which the twist should give, would be lost. The reverse twisting always takes out more or less of the original twist. A twist of 16/12 turns is better than 16/14, and 18/12 turns (for the throwing of which a throwster will charge little, if any, more) is better than either, and is strongly to be recommended when the warp is to be heavily weighted or to be put to any unusual strain.

Tram is generally twisted from two to three turns per inch. Two turns, only, of twist will invite trouble and, in practice, two and a half and three turns are customarily used, the latter being preferable. For special purposes, more twist may be given, but such cases are unusual except when tram is hard twisted for crepes.

Reviewing what we have stated, it will appear that the great bulk of the thrown silk used in this country for organzine will be of two thread, 13/15 denier, silk with 16/14 turns of twist per inch, and the tram will average four threads of 13/15 denier silk, coarse, and will have an average of  $2\frac{3}{4}$  turns of twist per inch.

Long observation and numberless tests and experiments in Europe have led silk authorities there, to come to the opinion that an allowance of three per cent should be made for the twist take-up in both the organzine and the tram.

It may be remarked, however, that the conditions and practises here differ somewhat from those on the other side. For instance silk is generally thrown there *bright*, that is without using soap and oil in the soaking; the qualities, or grades, most used there do not average the same as those consumed in the United States; fine sizes of raw silk are more commonly used there than here, and they run their machines at slower speeds.

It will, therefore, be obvious that while the three per cent take-up may represent the European experience it does not necessarily represent what we should figure in America.

The writer's experience and observation, confirmed also by the experience of others, leads him to believe that three and a half per cent, at least, should be allowed for the take-up in twist of organzine, while for tram two and a half per cent should be sufficient. As a sound working rule I believe that an allowance of four per cent take-up for organzine and three per cent for tram should be made, and, even if this is a little too full in some cases, there will be others where it will be none too much.

Singles are generally thrown into hard twist and after a certain point, the shortening on these, and on hard twist tram, due to twist, increases rapidly. The variation is so great, under different conditions, that any exact rule for take-up is difficult to formulate.

An experienced throwster of hard twist tram for crepes gives the following figures :

- 4 thread crepe twist, 65/70 turns, 18% take-up.
- 5 thread crepe twist, 65/70 turns, 20% take-up.
- 6 thread crepe twist, 65/70 turns, 23% take-up.
- 4, 5 and 6 thread crepe twist, 50/55 turns, 15% take-up.
- 4, 5, and 6 thread crepe twist, 45 turns, 10% take-up.

Some tests made by the writer, on five thread, 13/15 denier, Japan tram, showed the following take-ups: 32 turns, 6% ; 48 turns, 12% ; 72 turns, 19%.

On four thread Canton tram, 14/16 denier, the take-up for 72 turns averaged 16%.

In making cost calculations, therefore, the figures will be materially affected by the take-up in the throwing of the silk, and proper provision for this should never be overlooked.

**THE MANUFACTURE OF OVERCOATINGS AND CLOAKINGS.**

**Beavers.**

(Continued from page 130.)

**B. Using two systems warp and one kind filling.**

In this instance, the one kind of filling is made to interlace with the two systems of warp, part the time as face and part the time as back pick, the weave used being technically known as the double plain beaver weave, see Figure 8. The repeat of it is 8 by 4. In this weave, warp threads 1, 3, 5 and 7 are the back threads, and 2, 4, 6 and 8 the face warp threads. With reference to the filling, it is seen that every pick interlaces alternately for four ends as face pick, and four ends as back pick.

A standard make up for this class of fabrics is best given to explain the subject.

*Warp:* 68 ends, 55 inches finished width=3740 ends in warp.

10% take up in weaving=4155 yards, 2 1/4 run yarn=18.42 ounces.

*Filling:* 78 picks per inch in finished fabric, 20% shrinkage at fulling=65 picks per inch in loom, 85 inches width of fabric in reed, 4 run filling=13.81 ounces.

*Weight of fabric:* from loom (18.42 + 13.81 + 0.25 oz. selvage=) 32.48 ounces; finished weight 28 ounces.

**C. Using two systems of warp and filling.**

**(1) ARRANGEMENT OF WARP AND FILLING 1:1**

Weaves figures 9 to and inclusive to 13 are given to illustrate this subdivision of beaver weaves. In all five examples

Diagrams *a* show the face weave, in *square* type, Diagrams *b* show the back weave, in *cross* type,

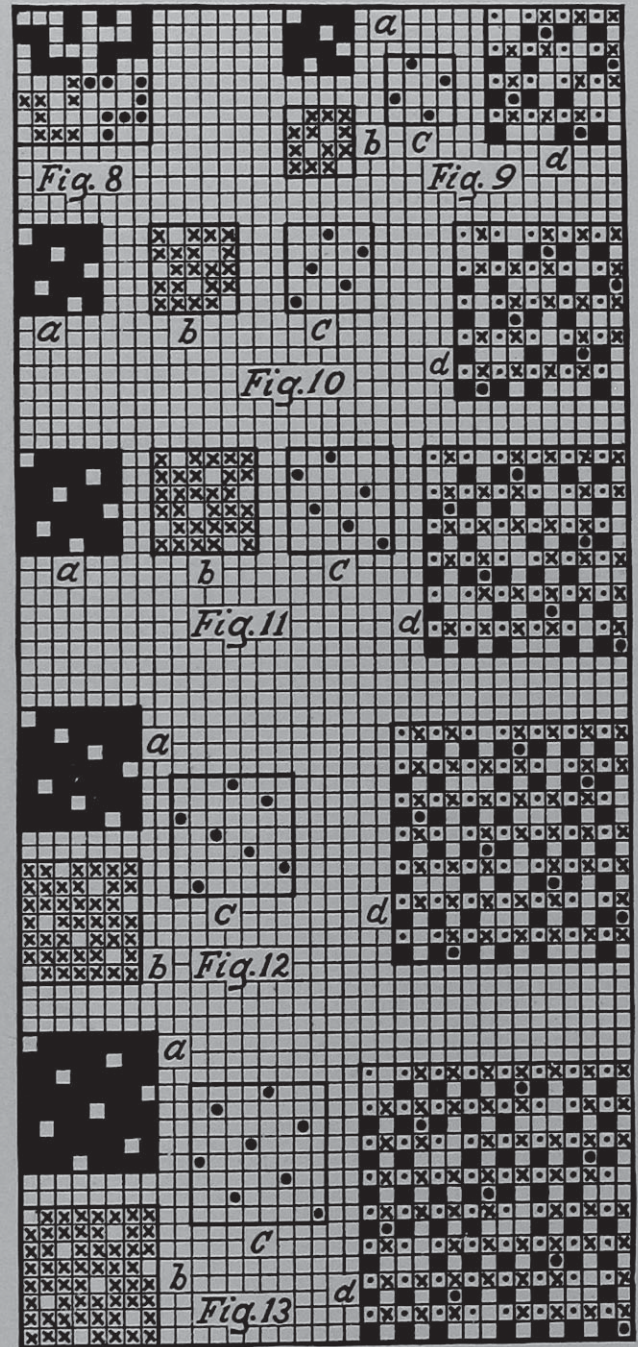

Diagrams *c* show the stitching of the two ply fabrics, i. e., the raising of the back warp into the face structure, in circle type;

Diagrams *d* show the complete double cloth weave, in type corresponding to that used in diagrams *a*,

*b* and *c*, plus dot type as is used for indicating the raising of every back warp thread on every face pick.

Figure 9 shows the 4-harness broken twill, warp effect, used for face and back weave; its mate filling effect being used for stitching, *i. e.*, uniting both plies into one structure. Repeat of the double cloth weave is 8 warp threads and 8 picks.

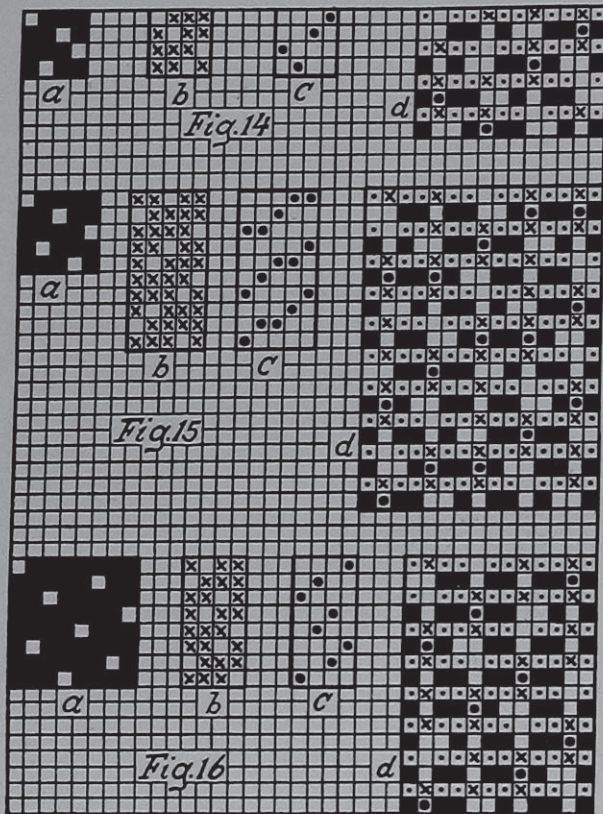

Figure 10 shows the same treatment observed in connection with 5-harness satin weaves. Repeat of double cloth weave 10 warp threads and 10 picks.

Figure 11 shows the same treatment observed in connection with 6-harness satin weaves, resulting in a double cloth weave repeating on 12 warp threads and 12 picks.

Figure 12 shows the same treatment observed in connection with 7-harness satin weaves, resulting in a double cloth weave repeating on 14 warp threads and 14 picks.

Figure 13 shows the same treatment observed in connection with 8-harness satin weaves, resulting in a double cloth weave repeating on 16 warp threads and 16 picks.

(2) WARP 2:1, FILLING 1:1

Three examples of weaves constructed by this arrangement are given, *viz*: Figs. 14, 15 and 16.

Figure 14, has the 4-harness broken twill, warp effect (*a*) for face as well as back (*b*) weave, its filling effect (*c*) being used for the stitching of both plies. *d* shows the complete double cloth weave.

Figure 15. Face weave 5-harness satin, warp effect (*a*); Back weave the 5 by 10 skip twill, skipping filling ways (*b*), the stitching of both plies being done

by means of arrangement shown in diagram *c*, resulting in the double cloth weave *d*.

Figure 16 shows the 8-harness satin, warp effect (*a*) used for face, and for the back structure the 4 by 8 warp effect  $63^\circ$  twill shown in diagram *b*, the latter weave, filling effect (*c*) being the arrangement used for combining both plies into one fabric in order to obtain double cloth structure *d*.

(To be continued.)

**A New Weave for Double Faced Terry Pile Fabrics.**

The new fabric structure refers to what is known as Turkish towels, the object being to produce a firmer interlacing of the pile loop to the body structure, with the result of a more durable fabric. The accompanying illustration is a diagrammatical perspective view of the new method of interlacing warp and filling, both being drawn enlarged and the individual threads unduly separated from each other, in order to give a clear understanding of the interlacing of the two systems of warp with its filling.

*Warp*: There are four threads to the repeat, *viz.*, *a*, the pile warp threads, and *b*, the ground warp threads.

The loops are beaten up at certain picks as the fabric is woven, this being permitted by the slackening of the pile warp threads as they are fed from a separate beam; *i. e.*, two beams are used in the construction of these fabrics, one for the pile warp and the other for the ground warp. Where the loop is formed, the pile warp threads pass over or under two picks, both the upper and lower loops being formed along the line of the same two picks, whereby a complete course of loops (alternately on the face and back of the fabric) is formed, crossing its width coincident with these two picks (1 and 2), and which recur at intervals of six picks, that is to say, there are four other picks (3, 4, 5 and 6) between each of

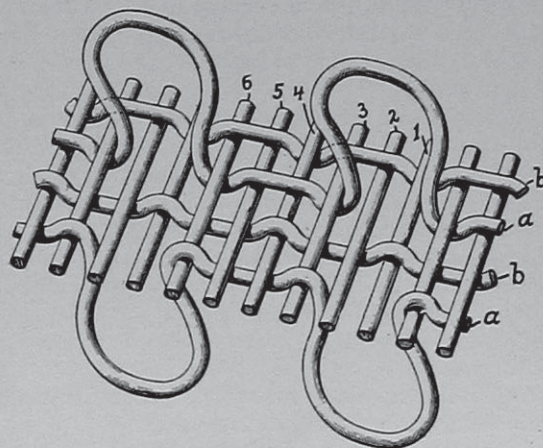

these two loop picks (1 and 2), the first of said four (pick 3 in diagram) being the pick by which the loops are beaten up, the other three constituting binding picks, whereby the loop warps are firmly interwoven with the picks during the intervals between the loops.

## ANALYSIS OF WOOL FIBRE.

To discover special forms of structure of wool fibres, the microscope must of course be employed, but the fibre is apparently so uniform throughout, and the lines of structure so weakly defined on account of its transparency, that they may only with considerable difficulty be detected. If, therefore, a specimen of

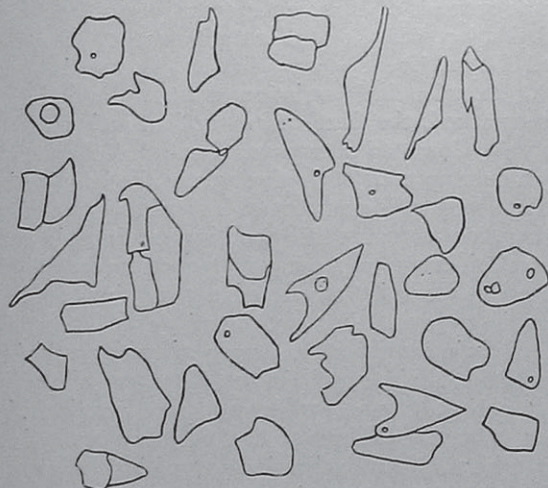

FIG. 1

wool be enclosed in any properly refracting and transparent medium, such as water, oil, solution of gum, resin or balsam, and examined in the microscope with transmitted light, its image presents the appearance of a more or less broad transparent band. With a microscope of high magnifying power and with the light passing through the fibre, and the instrument to the eye properly directed, faint lines may be seen crossing the image in a more or less irregular way, while the edges of the image will appear either almost perfectly regular, or it may be slightly serrated, or more properly dentate, the latter quality differing in intensity with the race of sheep from which the fibre had been taken. Other than this, and with one further exception, the fibre thus presented appears to be perfectly amorphous and very transparent. This further exception to be noted is found in the pigment, that is deposited throughout the centre of the fibre of certain breeds of sheep, and of which it appears to be almost characteristic.

If under ordinary conditions the fibre appears to be amorphous in its internal structure, it is quite different when examined after being subjected to the action of re-agents which may impair its transparency, or effect its partial or complete disintegration. Under such circumstances it appears to be cylindrical in shape, covered with irregular scales or epithelia, and consisting of a bundle of elongated fibres, sometimes surrounding a central cellular cavity or canal filled with granules of pigment. These appear to be three principal parts of the fibre of importance in either a theoretical or practical way, and we shall therefore develop them separately.

If a bundle of fibres of wool be placed upon a glass slide covered with either sulphuric or acetic acid, or with solutions of the fixed alkalis, they quickly

begin to swell, and upon examination with the microscope the transverse markings already mentioned become prominent and the irregularities or serrations at the edges of the image more marked, while longitudinal striations become apparent within the body of the fibre. If to the re-agents thus employed there be added any substance that may of itself or by subsequent change further impair the transparency of the fibre, many of these characteristics become more completely developed and visible, and may be very readily studied. To this extent this preparation of the fibre presents but little difficulty, but to effect the development of the external markings to such a degree that they may be thoroughly studied without causing too great distortion of the parts, involves the exercise of greater care.

However, for the study of the minute structure without reference to differences depending upon breed or external conditions of the fibre under examination, the re-agents we have mentioned will fully suffice. Of these we choose for the first gradual disintegration of the fibre, that recommended by Nathusius and Bohm, *viz.*, sulphuric acid. If, as already stated, the fibre be placed upon a glass slide and covered with a glass cover, a small drop of water having been applied to hold the cover in position, one or two drops of very strong sulphuric acid be applied to the slide near the edge of the cover, it will spread, and upon



FIG. 2

reaching the latter will be drawn under it by capillary attraction. If then the slide be placed upon the stage of a good microscope of fair magnifying power, the changes which the fibre will undergo may readily be observed. The first that may be noticed is a gradual swelling or expansion of the fibre and almost concomitant with this, the transverse markings, not readily observed without oblique light, make their appearance and very often, unless very strong acid has been employed, no further action seems to take place. If

now the slide be removed from the microscope, gently warmed over a lamp, and quickly returned to the field of observation, the transverse markings become more prominent, the serrations at the edges of the image more distinct and finally very thin scales or *epidermal epithelia*, as they may be called, begin to curl at their edges, which cause the transverse markings to ultimately separate from the main body of the fibre, and float away through the acting medium.

As soon as they separate from the fibre, and even before being completely free, they curl upon them-

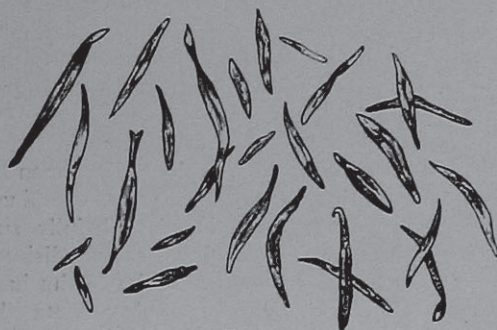

FIG. 3

selves, and finally roll into compact coils, so that in their free condition their form cannot be determined with any degree of satisfaction. They are very thin, according to Nathusius, having a thickness of only 0.0014 millimetre and very transparent. But if, when the acid has so far acted upon the fibre that it has become thoroughly softened, and before these epidermal scales begin to curl, they be subjected to strong pressure through the medium of a cover glass and without any lateral motion to cause abrasion, the fibre may be completely flattened; the epidermal covering seems to split in the direction of the length of the fibre, and spread out, affording an excellent opportunity for the study of the form of these scales or epithelia.

Their form naturally varies greatly with the variety of fibre to which they belong, and, in the comparison of the external characteristics of the fibres of different breeds of sheep. They form nearly annular layers about the shaft of the merino fibre, being very narrow in the direction of the axis of the fibre, and comparatively very wide in the direction of the circumference of the fibre in the finer staples and of very irregular forms in the fibres of the coarse-wool breeds. Some of these forms as separated by the acid mediums are illustrated in Fig. 1, representing specimens separated from a Cotswold fibre, and as seen floating about in the mounting medium. As they separate, they appear to be arranged upon the fibre in somewhat the same manner as the scales on a fish, and they should therefore tend to confer upon the fibre the felting property for which wool is celebrated and upon which the value of the staple for manufacturing purposes so largely depends. But the matter of their attachment must still remain an open question, though the action of these scales in the felting operation need be no matter of doubt. As will be seen in the illustration they are usually very irregular in form, especially in the coarser wools. In some cases we may detect

markings which seem like *nuclei*, but these are so ill defined, and appear so much like particles of fatty or other extraneous matter, often attached to the fibre in the raw condition, that we can scarcely accept them as nuclei. Many of these scales are entirely free from any such markings, and probably represent the true character with this regard.

After the fibre, immersed in the sulphuric acid, has been deprived of this outer covering of epiderma epithelia, or scales, it suffers still further disintegration. To hasten it, warming as before may be necessary. Longitudinal striations appear and become more marked, the fibre more swollen, and eventually it breaks down to a mass of elongated fibrous cells which overlap each other throughout the length of the shaft. These cells are more or less spindle-shaped, and as they float through the mounting medium, in consequence of currents produced by pressure applied to the cover glass by means of a mounting needle or other instrument, they are found to be flattened or oval in their cross section, nearly of uniform thickness throughout their length in the direction of one axis but tapering toward each end in the direction of the other. Generally they may be completely severed from each other, by gentle abrasion caused by a slight pressure and movement of the cover glass, but very often they separate in bundles or clumps. Here their arrangement as regards each other within the fibre may be more easily observed and they are found to be arranged in much the same manner as the ligneous fibre cells in vegetable tissue. In many particulars they are comparable to the latter, and with this difference, that when thus treated, they are more pliable. Thus the cells are arranged as shown in Fig. 2, at *a*.

If the portion of the fibre thus under examination have suffered rupture at any point, the fibrous cells are partially separated and give the appearance of great laceration at the ends. When motion of the mounting medium (that is, of the sulphuric acid above referred to) is set up by pressure upon the cover-glass, the disconnected ends may be seen to sway backward and forward with it until they are finally detached. This is illustrated in Fig. 2 in the cells shown at *b*. These cells sway backward and forward for a time, then loosen themselves and float away through the medium.

Both before and after detachment in different positions in which they may be examined, it seems impossible to detect any signs of nuclei, though they are said by some authorities to exist. There are some markings, which seem somewhat like elongated nuclei, but there are many reasons for the belief that these may be due to refractions of light passing through them and caused by longitudinal striations that may often be distinctly seen, as shown in Fig. 3.

The cells are more or less flattened, and are sometimes more or less twisted upon themselves, so that these light effects may often become exaggerated; and unless nuclei may be better defined than we have been able to see them, their presence must still remain a matter of doubt. But in the study of the cross section of the fibre some kind of a central marking is very prominent.

Nathusius says with reference to these cells: "It is difficult to state what may be their size, for they often vary in the same specimen when differently treated. It is probable that they are separated by the solvent action of sulphuric acid upon the true cell membrane, and the horny kernel alone is apparent, so that we may only guess at the true dimensions. This fibrous tissue is swollen by water, and sulphuric acid must swell it even more." The tissue consisting of these elongated cells, therefore, constitutes the principal body of the fibre. In some of the coarser fibres there may be found within this portion a central canal of cellular cavities filled with a characteristic granular pigment. When stronger acid is employed, stronger heat applied, or the action more prolonged, the cells become finally dissolved and disappear.

### POINTS ON LOOM FIXING.

By Wm. Secor, Master Weaver.

One of the greatest annoyances met with in a weave room, is the *throwing out* of shuttles. It will occur more frequently in some mills, than in others, depending on the class of work, and the skill of the fixers and weavers employed. It is an annoyance which the average mechanic would consider easily remedied, because he may think that setting the picking motion of the loom properly is all that is required and that there will be then no shuttle flying out to contend with, more so since the picking motion in itself is a most simple device, easy and quickly set and adjusted. Now this is where the difficulty comes in, since, if the matter would simply refer to the proper adjustment of this picking motion, there would be little trouble and annoyance for the fixer, as well as the weaver. However, considering the matter more carefully, this is possibly the least cause for the shuttle flying out.

Previous to investigating the causes for the shuttle being thrown out, we will have to take into consideration, the damage done by it. Not only is it a dangerous affair, since it may hurt the person which the shuttle strikes, plenty of instances being on record, where the weaver, etc., has lost his eyesight or got badly hurt otherwise by means of this annoyance. Windows near the looms are generally protected by means of wire screens, in order to save glazier bills, etc. However, the most frequent damage caused, is that the shuttle in flying out will break any amount of warp threads, in some instances cut holes in the cloth, etc., items which certainly are not only annoyances, but in many instances are rather expensive to the mill, on account of waste of yarn, and imperfections to the cloth.

One of the most annoying affairs, is the fact, that this flying out of the shuttle may occur at any time, and generally does occur when least expected. It is annoying to the weaver, since he will expect it to re-occur at any time and become timid, when as a fact, the affair may not happen again for days or months. It is this latter trouble which is the most annoying to the fixer, since the less frequently this flying out of

the shuttle happens, the harder it can be remedied; whereas it will be easy for any fixer to stop the flying out of shuttles if it occurs regularly at stated intervals, either on certain picks of the *round* of the harness, or the box chain, since then the fixer can locate the trouble at once.

**THE WEAVE.** We will now inquire into the causes for shuttles flying out, and when the weave plays a most important part. It will teach us, that when using complicated cross draws, that there is a greater chance for the shuttle to fly out than when using straight draws, or possibly, simple, more or less regularly arranged cross draws. Complicated cross draws, or cross draws which are apt to cause the shuttle to fly out, are such when the harnesses carry uneven quantities of heddles on their shafts.

For example. Take a 12-harness draw, with 10 harnesses carrying about 500 heddles each, the other 2 harnesses only about 75 each. In such an instance, the designer must be careful where to place these two light harnesses. If he has had practical experience on the loom, either as a fixer or a weaver, there will be little difficulty, since he naturally will arrange these harnesses in the draft to the best advantage for the fixer. But there are students who will draft the weave according to rules, never taking into consideration, the practical end of the work, and who then, by accident, may place these light harnesses in the wrong position. Practical designers will remember, that the heavy harnesses, *i. e.*, the harnesses which carry the greatest number of heddles, will make no trouble to get down on the race plate, both on account of its own weight, as well as the fact that the great many warp threads they carry will tend to pull down the harnesses. However, when the reverse is the case, and such heavy harnesses have to be raised, there is a chance for the jack fingers to slip from the lifter bars, before the shed is fully open. When this occurs, there is a chance for the shuttle to fly out. Now with reference to the light harnesses, they will be the ones which cannot be handled so easily, since they may refuse to go down readily to the proper level of the shed, keeping the threads they carry possibly a half inch above the race-plate, and being thus in a most inviting position for the shuttle to take a sudden spin through the shed, hitting the arm, etc., of the weaver, at the same time, breaking as many warp threads as possible, all of which have to be retied again by the weaver. If you have to use an arrangement of harnesses, as just referred to, always place the heavy harnesses in the back, and those carrying the least number of heddles or warp threads, nearest the reed. This placing of the different loaded harnesses in the loom, should be remembered by every designer when making out the drawing in drafts. When meeting a different arrangement used, consequent chances for the throwing out of shuttles will manifest themselves. Some fixers prefer the heaviest harnesses placed in the middle of the set, which is also a good arrangement, that is provided they place the lightest loaded harnesses toward the reed. Placing the light har-



nesses nearest the reed, gives the fixer a chance to take good care of these light harnesses, for the fact, that the front harnesses will always work closer to the race-plate than the back ones.

**SHUTTLES.** To use the proper shuttles and see that they properly box, will go far in preventing the flying out of the shuttle. Keep your shuttles from striking on the side, top or bottom of the shuttle box, this will prevent shuttles from flying out. When using 2, 3 or more shuttles at one time, be careful that they are all of the same weight, and not that, for example, you run three shuttles of a uniform weight, and one of a lighter weight, the latter being then the one most likely to do the damage, on account of being so much lighter than the rest. When the yarn is about run off the bobbin, the weight of the shuttle with its load of yarn is still further reduced, and when then the speed should slow down a trifle the power of the picking motion then may be not enough to drive the light shuttle fully into its box. We must remember, that most likely the fixer sets the power for the picker by one of the heavier shuttles. The light shuttle not boxing properly, *i. e.*, the shuttle not fully in the box, will be the cause for the box being caught, and when on the next pick of the loom, two shuttles may come together, one flying out, and the other weaving. The shuttle box being caught, throws the protector out of operation, causing the whole mix up to end in a grand smash. Not only is it the weight of the shuttle, but at the same time its size which must be taken into consideration. All the shuttles used at one time on the loom, must be of uniform size. Remember that, if there is a somewhat smaller shuttle in your set, there is a good chance for the same to rebound in the box. On the next pick, where the said shuttle is to travel through the shed, the power will then be insufficient to properly throw said shuttle through the shed, for the fact, that the picker in its travel reaches the point of the shuttle late, *i. e.*, an insufficient momentum being given to the shuttle. Either try to get the proper companion of a shuttle for the set, in place of this light or smaller shuttle or get a new, good set of shuttles. A poor set of shuttles will cause them to fly out, with a consequent damage to the cloth, which has been previously referred to. Poor shuttles are a most expensive item to the mill.

When shuttles will fly out, they will themselves get damaged. For instance, the point of the shuttle may strike a hard piece of machinery, the frame of the loom, a pillar of the mill, etc., with the result that the point of the shuttle will get ruffled, and if not detected and smoothened, may be the cause of breaking warp threads, etc. Again, the shuttle may not fly away from the loom, it may only hit the top or the bottom of the box, a feature which is apt to raise splinters on the shuttle and later on cause a smash.

It is the great speed, at which a shuttle travels, that makes it difficult to keep in the shed, except everything works smooth and even. The least trifling thing will throw the point out, and then the body of the shuttle will promptly follow.

(To be continued.)

## COTTON SPINNING.

**RING SPINNING:**—A General Description of the Modern Ring Frame—The Creel—Roll Stands—Weighting Rolls—Top Rolls—Bottom Rolls—Clearers—Care of Rolls and Roll Stands—Faulty Work of Rolls—Thread Boards—Rings—Ring Holders—Size of Ring to Use—Traveler Clearers—Setting Rings—Care of Rings—Finishing of Rings—Ring Travelers—The Action of the Traveler—How Travelers are Made—Weight of Travelers—Spindle Rails—Spindles—Setting Spindles—Lubrication of Spindles—Bobbins—Bobbin Clutches—Banding—Banding Machine—Band Tension Scale—Tin Cylinders—Ballooning and Separators—Winding—Builder Motions—The Warp Builder—How to Set the Builder Motion—The Filling Builder—Spinning Filling on Paper Tubes—The Combination Builder—The Care of Ring Rails and Lifter Rods—Some Causes for Badly Shaped Bobbins—Doffing.

**NOTES:**—Management of the Spinning Room—Data on Ring Frames—A new Spindle Drive Device—Care of Machines—Oiling—Leveling Frames—Power Tests—Power Consumption—Arrangement of Machinery.

**FAULTY YARNS:**—Knots and Bunches—Variations in Counts—Uneven Yarn—Thick and Thin Places—Weak Yarn—Kinky Yarn—Dirty Yarn—Kockled, Curled or Knotty Yarn—Slack Twisted Yarn—Hard Twisted Roving—Cut Yarn—Harsh or Wiry Yarn—Badly Wound Yarn—Bobbins Wound too Low—Soft Wound Bobbins—How to Prevent "Double"—Colored Work—Waste—Breaking Strength of Yarn.

**CALCULATIONS:**—A general Description on the Subject of Draft, Twist, Production and Gearing—Calculating the Draft from the Gearing—To find the Draft—To find a Constant—To Ascertain Draft Change Gear—To Ascertain Hank Roving—To Ascertain Draft—Twist—Standard Twists—Contraction Due to Twist—Notes on Twist—Calculating Twist—To Ascertain Speed of Spindles—Calculating Twist from Gearing—Traverse Gear—Taper—Sizing the Counts—The Grading of Cotton Yarns, Single, Two or More Ply—Production—Programs for Spinning Yarns of Various Counts, from Bale to Spun Thread—Illustrations with Descriptive Matter of the Different Makes of Ring Frames.

### The Ring Frame.

(Continued from page 150.)

Another make of a metal thread board, provided with a universal adjustment for its hardened steel thread guides, is shown in Fig. 251, applied in this instance to a wooden back rail. One of the two finger boards is shown raised, in order to expose its adjusting mechanism for the thread guide rod; the other finger board being shown down or in its work-

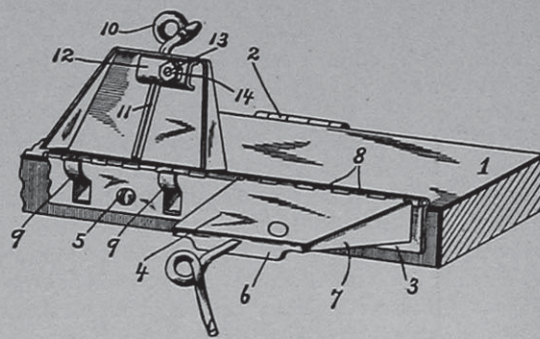

FIG. 251

ing position. Of numerals of reference accompanying the illustration, 1 indicates a portion of a wooden back rail of a thread board, hinged at 2 to the roller beam. A sheet metal piece 3 is made as a portion of a hinge for the finger board 4, and is secured to the back rail 1 by means of screws 5. These pieces 3 also act to strengthen the board 1 and prevent it from warping, at the same time ensuring accurate spacing of spindles. The finger boards 4 are each stamped out of a single

piece of sheet metal, forming a body portion and having a depending front flange 6 and side flanges 7. At its rear edge, each finger board is provided with sockets 8 for a hinge pin, and which are below the level of the upper surface of the finger board. This construction leaves the rear edge of each finger board

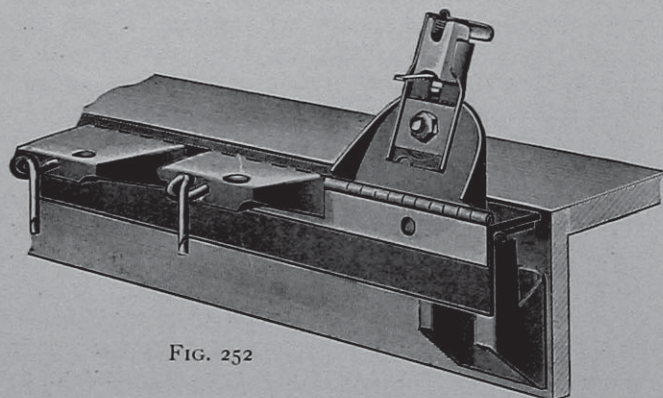

FIG. 252

unobstructed, so that dirt or dust collecting on it can be readily wiped off. The flat ends of the side flanges 7, of each finger board, form stops for holding the same in its normal horizontal position. Stops 9 made of part of the piece 3 and bent out into fingers, can be provided if so required; being however, frequently omitted. The thread guide 10 is made with a triangular shank 11, which prevents the guide from turning and displacing the thread catcher (for the latter see outside end of thread guide to the right hand in illustration) and also allows the guide to be hardened without liability of breaking. These guide wires are made from steel wire and will show no signs of wear after years of use, they simply presenting a highly polished appearance. Each thread guide is secured to its support by means of a clamping piece 12, which is U-shaped in cross section, the flanges or edges of which are notched to correspond to the triangular shape of the thread guide shank. Extending down through each clamping piece 12, from its finger board, is a blank headed screw 13, threaded onto the end of which is a nut 14. The head of the screw 13 fits into an integral socket in the finger board, and to hold the screw from turning, the head of the latter is provided with small wings or projections. By means of this construction, the smooth head of the screw is brought down flush with the surface of the finger board, so as to retain a smooth uninterrupted face over the entire upper surface of the latter. The thread guide is set in the position desired, by simply loosening the nut 14, placing the eye so that it will be directly over the centre of the spindle and then tightening said nut 14, the triangular shape of the shank and its socket preventing any slippage by axial rotation. The guide wires thus adjusted are then held so firmly and solidly that when once adjusted, they require no further care from the operator.

These steel thread guides and their finger boards, as shown adjusted to a common wooden back rail, can, and more properly so, be also used with a metal back rail having counter balanced hinges, as is shown

in connection with Fig. 252. In this instance the sheet metal piece 3 (see Fig. 251) is riveted to the metal back rail in place of using screws 5, as was done with the wooden back rail. In Fig. 252, two different kinds of thread guides are shown; two steel thread guides, as previously explained, are shown down or in working position, the other thread guide, as shown turned back, referring to a porcelain thread guide, being shown in this position to illustrate the adjustment of the porcelain pot or eye to its finger board; all three thread guide supports being shown applied to a metal back rail. We see from it that these kind of thread guides have the same easy adjustment to their supports as do the steel guides previously explained in connection with Fig. 251, and that each guide support is independent of the others, with a separate adjustment for each thread guide eye. The porcelain pot, *i. e.*, porcelain portion of the guide eye, as will be seen from the illustration, is firmly held between the two upturned side flanges of the metal portion of the guide. Other features of this thread guide are its metal threading finger, for guiding the thread to the eye as well as to hold the thread in the eye during spinning, a stamped out portion of the slot of the guide is bent up for the purpose of a snarl catcher, at the same time preventing any possible chance of the porcelain pot from sliding backwards; as well as the adjusting nut for regulating the proper position of the guide eye. The porcelain pot eyes, when grooved, can be removed, and this, as will be readily understood, at little expense.

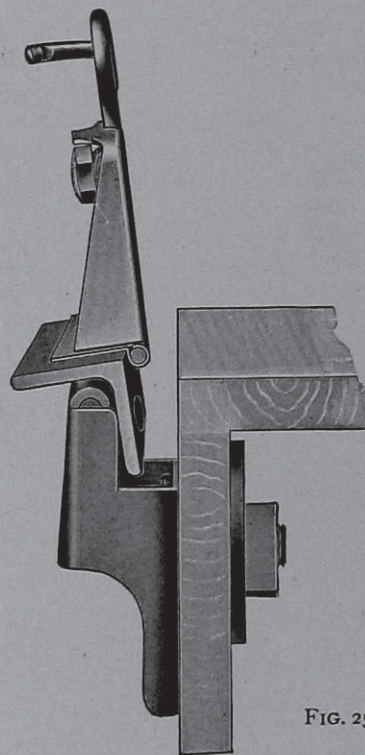

FIG. 253

The metal back rail for thread boards is a most ingenious adjunct to any thread board. Its hinges, as carried in suitable brackets adjusted to the roller beam of the machine, are so constructed (counter balanced) that the rail is held in position by its own weight,

either while spinning (see position of back rail shown in Fig. 252) or when turned back for doffing, see Fig. 253, and requires no lifting device or brackets to hold it in the latter position. In the wooden thread boards, some kind of lifting device and arrangements for holding up the rail while doffing has to be provided, and the operator must go to this device to lift and also to drop the back rail. This requires the operator to walk, twice the length of the frame at each doffing, a loss in time overcome by the metal back rail shown in our illustration, since the same can be lifted back or down from any point; it being self balancing, by its own weight, naturally holds itself up when turned back for doffing, and also down in position for spinning. This metal back rail will also prevent all warping or sagging which may occur with wooden back

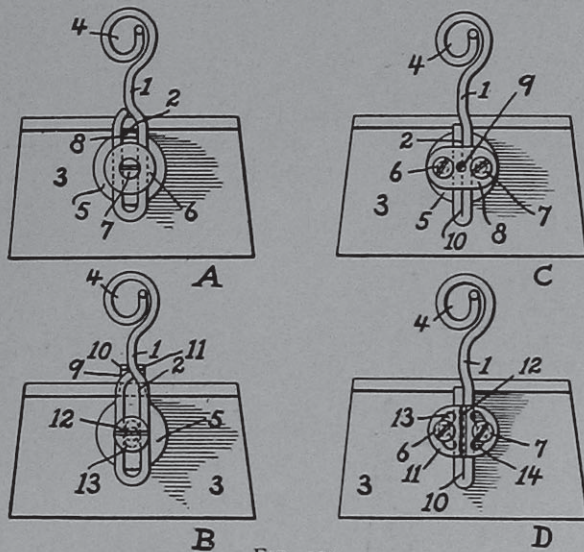

FIG. 254

rails, a feature, which considered with the necessity of humidifiers in a spinning room, will also be a strong point in favor of a metal back rail, since they are not affected by the moisture in the air.

Another thread guide possessing universal adjustment is shown in Fig. 254 in four variations of construction, it referring to *The Palmer Thread Guide*. The under side of the finger board is shown in order to illustrate the methods of adjustments of guide to finger board.

With reference to the construction of the thread guide shown in connection with diagrams *A* and *B*, the same consists of a piece of wire having its shank 1 turned back along itself so as to form the elongated open loop 2, for the reception of the fastening means for securing it to the finger board 3, the opposite end of the said wire being bent to form the eye 4 of the guide. The part of the shank 1 which forms the loop 2, rests on a flat washer 5, and is held in the desired adjustment, both longitudinally and in a swinging direction, either by means of a clamping plate 6 (see diagram *A*) which is forced down against the loop portion of the shank by means of a screw 7, which passes through the clamping plate 6 and through the

loop 2 and washer 5 into the finger board 3; or by the head of the screw itself, as shown in diagram *B*. The face of the washer 5 in the construction shown in diagram *A* is provided with a teat 8, struck up from the body of the washer 5 and by extending between the sides of the loop, forms a bearing to hold the latter in position, while the washer 5 will be held in place by the frictional contact between it and the finger board; or the washer may be provided with a neck 9 (see diagram *B*) and a pair of lugs 10 and 11 at its end, to embrace the shank 1 in proximity to the doubled portion, and the screw hole in the washer may be elongated, as shown in dotted lines. When the clamping plate 6 is omitted, the head of the screw 7 is then enlarged, forming, in effect, a clamp screw 12 as shown in diagram *B*, where the head 13 of the screw is shown to be sufficiently large to overlap the opposite parts of the loop portion of the guide, so that the screwing of the screws 12 into the finger board 3 will clamp the guide in such adjustment as may be desired, both in a longitudinal and swinging direction. In place of being straight, the shank of the thread guide—if so desired—may be offset, so as to bring the guide eye into the central plane of the finger board.

The thread guide shown in connection with diagrams *C* and *D* Fig. 254 consists of a piece of wire, having its shank 1 turned back along itself to form an elongated and laterally extended portion 2 for the reception of the fastening means for securing it to the finger board 3, the opposite end of the said wire being bent to form the eye 4 of the guide, the same as done in connection with the previously explained make of thread guide. The guide may rest on a washer 5, as shown in diagram *C* or it may rest directly on the finger board, as shown in diagram *D*.

In the form shown in diagram *C*, the guide is held in position by means of two screws 6 and 7, which pass through a clamping plate 8 and through the washer 5 into the finger board 3. The screws are located on opposite sides of the portion 2 of the guide and the clamping plate 8 is provided intermediate of the screws 6 and 7 with a conical projection 9 formed on its side toward the shank of the guide, by punching the clamping plate, and raising thereby a conical shaped projection. This projection 9 is intended to seat intermediate of the parts formed by the return bend of the shank and acts as a pivot on which the guide may be swung back and forth horizontally, while at the same time the guide is permitted to move outwardly and inwardly, the projection 9 sliding along a shallow groove 10 between the parts of the shank of the guide. In whatever position the guide be swung or adjusted, it is held securely in place by tightening the screws 6 and 7. In the form shown in diagram *D*, the washer is omitted and the clamping plate 11 held in position by screws 6 and 7, the clamping plate being in this instance provided with a rib 12, located transversely of the plate and in position to enter the shallow groove 10 between the parts of the shank of the guide, to hold it in position when the screws are tightened. The clamping plate

11 is provided with elongated openings 13 and 14, for the screws, so that the plate 11 may be tilted edgewise, carrying with it the shanks of the guide, to locate the guide eye in its proper horizontal adjustment, while at the same time, in order to make said adjust-

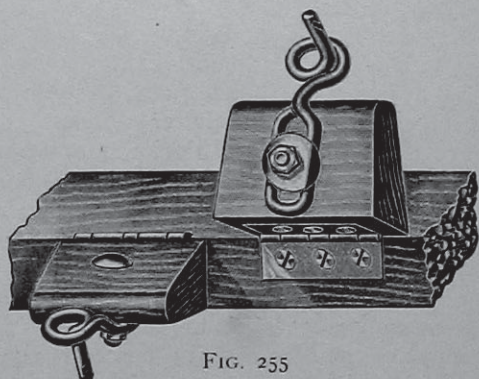

FIG. 255

ment true, the guide may be slid along the rib 12 to give it its proper adjustment outward and inward. Fig. 255 shows this Palmer Adjustable Thread Guide in its perspective view, applied to its finger board, it being shown in its working and its raised position for doffing purposes, the same referring more particular to the make shown and described previously in connection with diagram 254A.

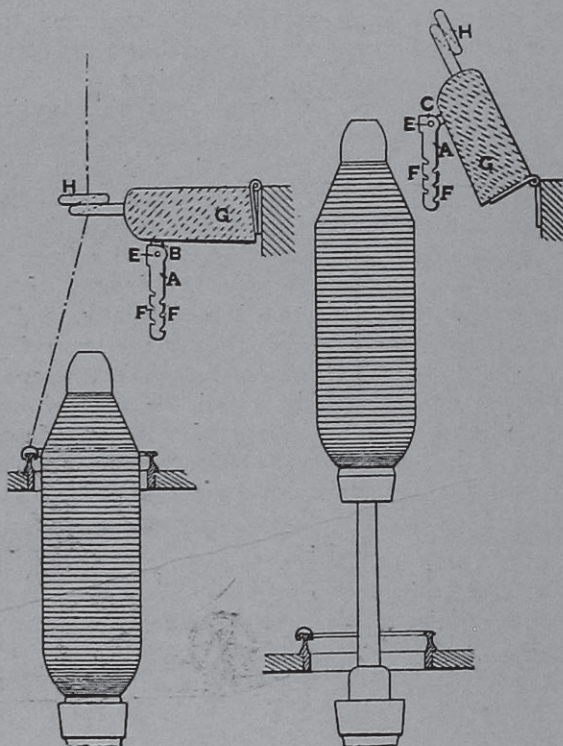

FIG. 256

FIG. 257

THE THREAD, KINK OR SNARL CATCHER, OR THREAD ARRESTER, as variously called, when used, is in most all instances made to form a part of the guide wire itself, the end of the wire, after forming the eye, being made to extend down in an oblique direction for about one inch, and is provided towards its end with a slot, *i. e.*, the thread catcher, as shown in connection with illustrations Figs. 247, 251, 252, 253 and 255.

Another style of a thread catcher (of English origin) is shown in Figs. 256 and 257. From these illustrations, it will be seen that in this instance the projecting leg of the thread guide for use as a thread catcher is dispensed with, a small bracket *B* being fixed in its place by means of a screw formed on the bracket to the under side of the wooden finger board *G*. This bracket *B* carries a small blade *A* made of sheet metal. This blade is pivoted to *B* in such a manner that it is only capable of moving in one direction, that being to fall back against the finger board when the latter is raised (see Fig. 257). Upon the finger board being lowered again, the blade *A*, automatically falls into working position. The blade, and which is made flat, is formed with serrations *F* on either side, and where it is pivoted to the bracket *B* it is formed with a three-sided slot or fork *C*. The bracket fits in the slot, and a pin *E* is passed through to hold *A*. When it is necessary to doff, the finger boards are raised and the thread catchers, as explained, fall against the undersides of the former. Upon the lowering of the finger boards, the catchers fall until they take up a perpendicular position, but cannot move in front of it because the back of the slot *C* comes into contact with the finger board and which acts as a stop. When a snarl is formed, or a broken end occurs, it is at once seized by the blade *A* or its notches. It will be seen that the catcher is out of the way during the operations of doffing and cleaning the frame. It prevents the broken end from reaching other adjacent ends, and as it is placed behind the spindles it does not interfere with the work.

(To be continued.)

#### Draper's New Traveler Holder and Pan.

This convenient attachment to ring frames is designed to hold the travelers in bulk, said travelers being contained in a suitable holder which can be moved manually to discharge at a time a few of the travelers into a shallow cup or pan from which they are taken by the spinner as needed, in turn preventing waste in travelers by the operator.

Of the accompanying illustrations, diagram *A* is a side elevation of the attachment, a portion of the cup being shown broken out. Diagram *B* is a right hand elevation of the device shown in Fig. 1. Diagram *C* is a top plan view of the holder, showing the closure therefor and the outlet for the travelers when the holder is moved to the discharging position. Diagram *D* is a cross section of the holder on the line *x — x*, diagram *C*.

With reference to these illustrations, 1 indicates the pan or cup for holding a few travelers at one time, delivered into it from the movable holder or cylinder 2, which is filled with travelers, and which holder has at its top a slot, widened along one edge, to leave a narrow elongated discharge opening 3.

4 indicates any convenient part of the ring frame to which pan 1 and the casing for holding the holder 2 are secured.

A longitudinal rib 5 is formed on the interior of the holder, opposite the slot, to act as a counterbalance,

that is, normally this counterweight will operate to retain the holder in position with the discharge opening 3 uppermost and under the overhanging arm 6, and if the holder is turned on its journals, this counterweight will retain it to normal position as soon as released. 7 is a movable cover; the holder being filled with a quantity of travelers in bulk, after which this cover is replaced and fastened.

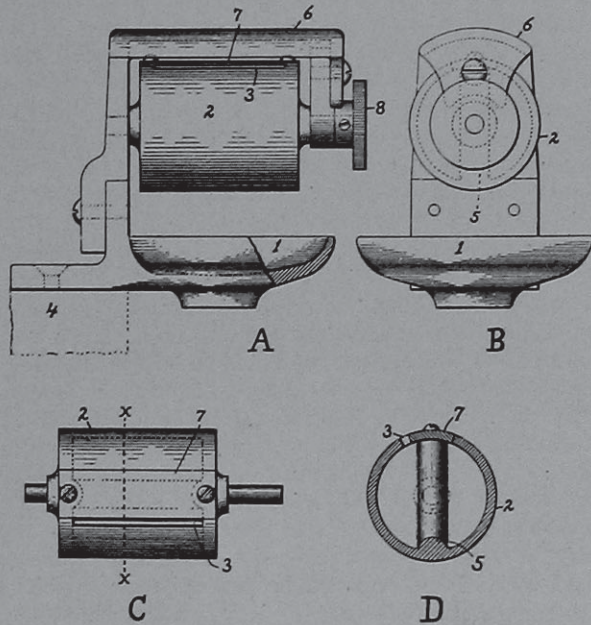

Draper's New Traveler Holder and Pan

When during working hours, the spinner requires one or more travelers, he then grasps the nut 8 and revolves the holder 2 to turn the discharge opening 3 downward, whereupon one or more travelers will drop out into the pan 1, but only a few of the travelers at most will be discharged, owing to the character of the opening 3.

The discharged travelers are then picked out of the pan by the operator and used as needed, the bulk of the travelers being retained in the holder and kept thereby from scattering or spilling over the floor.

As only a few of the travelers will be held in the pan 1 at any time, the operative will be more careful in their use and will not have the opportunity to waste them, as is now the case, for which reason this small device will repay its initial cost at a short time.

The overhanging arm 6 protects the discharge opening from the entrance of lint and fluff.

**Waste Conveyer For Woolen Cards.**

The purpose of the same is to automatically return into the hopper of the self-feed, all the waste, dropping and flyings, that escape during the process of carding, from below the swift and the doffer. In delivering this waste product into the self-feed, the same is then automatically mixed with the fresh stock and in turn re-used. Similar devices have been constructed before, but it is claimed that their drawbacks have been that they have a tendency to clog the machine, or to permit the escape of material at or near the

place where the conveyer discharges into the hopper-feed, being features overcome in the construction of the new device. Foreign impurities in the waste are during its transfer discharged, the device consisting of a screen apron which permits said impurities to drop through its interstices.

Of the accompanying illustrations, Fig. 1 is a side elevation and Fig. 2 a longitudinal vertical section of the new device (A), showing also positions of the self-feed (B), swift (C); and doffer cylinder (D).

With reference to the new device, 1 represents an inclined screen formed of parallel bars, having its upper end terminating at an opening in the case of the self-feed, located above an inclined extension 2 of the screen 3 of the self-feed.

4 are grooved rollers, which engage sprocket chains 5 extending parallel to each other and at opposite sides of the screen 1 and thence horizontally near the floor and beneath the swift. These chains move with their lower portions toward the self-feed, and with their upper portions away from the feed, whereby, as the material is discharged over the angle where the screen 1 and extension 2 join, the chains move then upward and away from the said angle, thus preventing any clogging of material.

The conveyer is driven from shaft 6, which drives the apron of the self-feed, whereby, whenever this apron stops, the conveyer will also stop and thus prevent feeding the recovered material into the bottom of the self-feed, while its apron is stationary.

To convey the material from beneath the swift C over the screen 1 and discharge the same upon the inclined portion 2 of the screen 3, leather straps 7 are attached to opposing links in the chains 5 by means of flat arms 8 extending from the respective links of the chain, these arms being offset vertically from the respective links to extend over the flanges of the rollers 4 and thence extended horizontally, and to which horizontal portions the straps 7 are secured.

To guard against breaking the chains, straps 7 are severed near the middle, and the severed ends secured to each other by means of a lacing, adapted to break under any unusual strain thereon, and less than the breaking strain upon the chains.

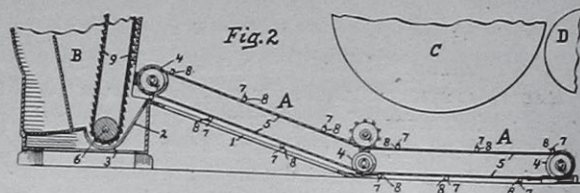
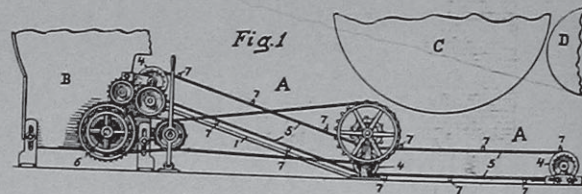

IN OPERATION, the impurities and stock escaping below the swift C, will fall upon the floor and be engaged by the straps 7 and carried up over the screen

1 through which the impurities will escape, leaving the useful material to be discharged upon the extension 2 of said screen 3, and upon which extension said material slides downward against the apron 9, of the self-feed, and is carried thereby over the screen 3, thus being further screened and separated from the impurities which pass downward through the said screen. There being no opening between the screen 3 and the extension 2, none of the material escapes, and as it is discharged by the straps, the latter are carried upward by the chains and thus the machine cannot clog at this point.

The apron 9 of the self-feed carries this recovered material up into the mass of stock in the hopper of the self-feed B, with which stock it is mingled uniformly by the action of the apron 9 and carried back again into the carding mechanism.

**An Ingenious Construction of a Clock for Silk Reels.**

The same refers to the machinery for reeling or winding silk as built by the Sipp Electric and Machine

Another feature accomplished is the means whereby the automatic clock-stopping mechanism is controlled in such a manner in the starting and stopping of the machine, that it will be practically ineffective at these times when the tension is not sufficiently constant, and will therefore not act as an undesirable check on the clock operating parts, which the threads control, and so possibly lead to the breaking of the threads because of sudden resistance to the pull of the reel.

Referring to illustrations, the thread *p*, on its way from the bobbin, is passed once around a peripherally grooved wheel *u*, made of aluminum, in order to be a very light affair, then over the thread guide 4, around wheel *u* again, and finally again engages the thread guide 4, and then passes through the eyelet or faller 1, from where in turn it then is guided onto the fly of the machine. The purpose of the guide 4 is to prevent the windings of the thread around the wheel *u* from overlapping with each other, the thread being passed around the wheel at least twice, in order to secure sufficient frictional contact therewith. A

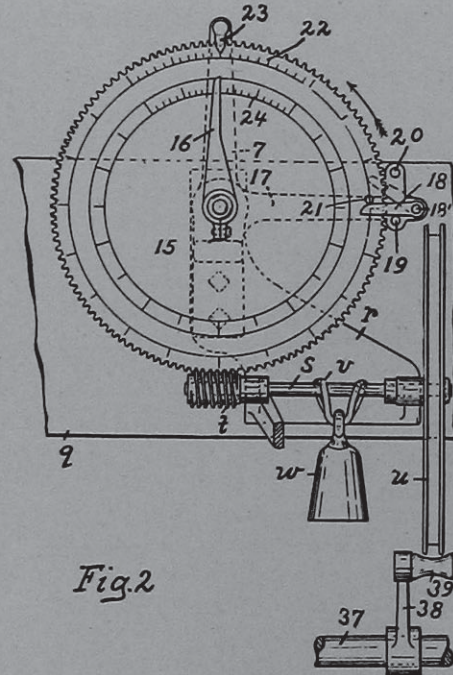
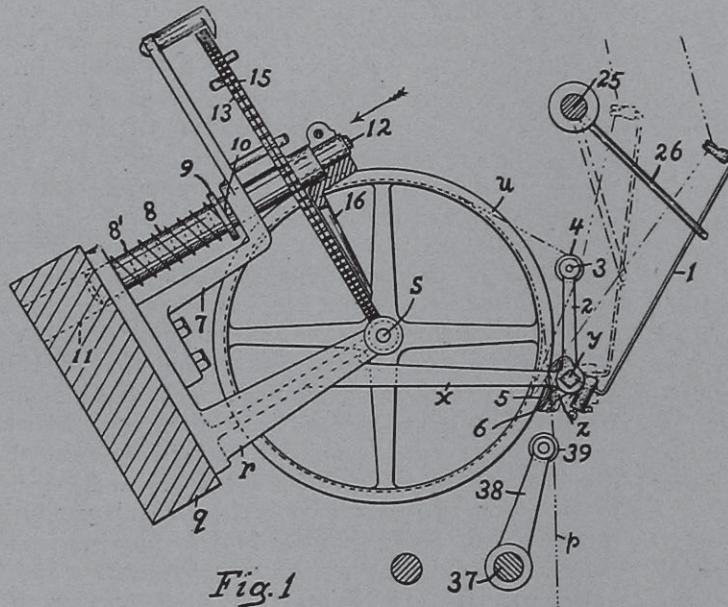

Co. of Paterson, N. J., and will be readily understood by consulting the accompanying two illustrations, of which Fig. 1 is a transverse sectional view of one of the measuring sections of the reel, as well as those parts as are more closely connected to it, the sectional view being taken just to the left of the clock, showing certain parts of the latter also in section. Fig. 2 is a corresponding view of what is shown in Fig. 1, looking in the direction of the arrow in said Figure, certain parts, for the sake of clearness, being omitted and others being broken away.

The object of this measuring device is *accurate work*, although the machine may run at a high rate of speed and thus make it necessary to take into consideration that the momentum of the parts which directly operate the clock under the influence of the thread being wound, tends to keep the clock operating or registering, after the need therefore has ceased, *i. e.*, when a thread breaks.

brakeshoe *z*, having a friction face 5 bears against the periphery of the wheel *u*, and since it forms an eccentric curve, it acts more or less on its first impact with the wheel to jam or bind therewith, the wheel from then on having a sliding contact with the brakeshoe until it comes to a stop.

The normal position of the faller 1 is shown in dotted lines; should the thread break, the faller will then drop into the full-line position, whereupon the brakeshoe will immediately act to stop the rotation of the wheel *u*, which in turn operates the clock, and thus secures an accurate registry of the amount of thread actually reeled by the machine prior to the breaking of the thread.

The bracket *r*, as secured to the rail *q* of the machine, carries the auxiliary bracket 7, in which is

arranged a longitudinally movable shaft 8; a spiral spring 8' being interposed between a washer 9 on the shaft, bracket *r* pressing a stop pin 10 in the shaft, against the bracket 7, the shaft being capable of being pressed back by hand into a hole 11 in the rail *q*. On the reduced outer end 12 of the shaft 8 is journaled a toothed wheel 13, and on the hub of the latter, a toothed wheel 15, the latter having one more tooth than the wheel 13. On the projecting end of the hub of the wheel 13 is secured the pointer 16, and which rotates with the wheel 13.

In the normal position of the parts, the wheels 13 and 15 mesh with worm *t*, but by pressing them back against the tension of spring 8' the worm will be cleared so that the wheels can be manually rotated. Bracket 7 carries an arm 17 in which is pivoted a bifurcated pawl 18 which normally rests against a stop 19 and may be moved upwardly as far as the stop 20, said pawl straddling the peripheral portions of the toothed wheels, each of which carries a stop pin 21, which, when the wheels are rotated in the direction of the arrow (Fig. 2) may pass the pawl 18, but will engage pawl 18 on the reverse rotation of said wheels, to limit their backward movement.

The wheel 13 has the scale 22, on which, by the aid of a stationary pointer 23, as is secured on bracket 7, the number of yards in fractions of ten yards may be read. The wheel 15 has the index 24 and from which, by the aid of the pointer 16, the number of yards in hundreds may be read; for instance, the wheels being initially set with their stop pins 21 against the pawl 18, one complete revolution of wheel 13 would show one hundred yards reeled off, and this would be likewise indicated by pointer 16 on the index 24 of the wheel 15, because, since this wheel has one more tooth than wheel 13, the pointer 16 would be opposite the first point from zero on the index 24. To reset the wheels, they must be moved back out of engagement with the worm *t*, the pawl 18 being axially moved therewith on its pivot 18'.

In starting and stopping the machine, the pull of the reel on the different threads is likely to be more or less irregular, hence to prevent the fallers from dropping and in turn applying the brake to the wheel *u* with the result that the sudden stop of the wheels would break the threads, fallers 1 are temporarily held at such times by means of a lever (not shown) in the dotted line position shown in Fig. 1 so that the brakes cannot operate.

#### The History of Silk Conditioning.

The first attempt to condition raw silk was made in 1684 in Italy, when a royal decree, issued the 15th of October of that year, in Turin, informed both sellers and buyers of raw silk that there was a possibility of establishing the true weight of raw silk in an impartial manner. At that period the conditioning of silk was a private operation of good faith between the two parties interested. Gradually the necessity developed for a public and disinterested testing house, and in 1724 the first conditioning house was founded

in Turin and opened for public service on the 8th of April.

The method of conditioning then adopted was: Raw silk skeins were suspended on sticks and exposed to the open air for 24 hours in large, open rooms in order to obtain uniformity in the condition of moisture of the silk. In summer time, the natural state of the atmosphere was considered propitious for the silk, whereas during the cooler part of the year the rooms were heated and the temperature of the air kept at 68 to 77° F. At the end of this drying operation of 24 hours the raw silk was considered to be in the proper condition of moisture.

On the 25th of March, 1735, the King of Italy issued a decree entrusting to the Consul of Trade the task of establishing detailed rules for the method of conditioning; also of appointing the manager and stipulating the charges to be collected for the operation. The receipts went to the treasury of the Consulate of Trade, a fact which means that this first conditioning house was an official institution.

In 1779 a merchant of Lyons, Mr. Rast-Maupas, made a trip through the whole of Italy and on his way back visited also the conditioning house in Turin. On his return to Lyons, he addressed to the Consul of Trade a request to be allowed to open a conditioning house in Lyons and asking for the exclusive right to condition raw silk for a period of 30 years. This request was rejected with the argument that the monopoly for conditioning silk could only be granted to the Board of Trade of Lyons, and not to a private individual. Consequently Mr. Rast-Maupas being convinced of the necessity of such an institution, opened a conditioning house out of his own funds without any official protection. He adopted a somewhat different method of conditioning than the one used in Turin. Instead of hanging the silk in open rooms on sticks, he had boxes or partitions of wire-grate, where the raw silk was placed in a loose manner and exposed to the freely passing air. Seller and buyer were present at the filling of these boxes which were then sealed. After 24 hours of drying, the seals were removed and the silk weighed net in the presence of both seller and buyer, and this weight was recognized as the official commercial weight of the silk. As in Turin the boxes were heated, or not, according to the season of the year. The Lyons system had the advantage of leaving the bale undivided and under seal, thus avoiding any mixing or theft. The success of this venture induced three other merchants of Lyons to establish similar conditioning houses. Consequently a strong competition amongst the four institutions sprang up with the result that the three younger concerns were ruined. The competition had affected the integrity of the operation, as improper means to influence the weight of the silk had been introduced in order to attract clients to these contestants, and these manipulations destroyed the good reputation of the Lyons Trade.

In order to overcome this drawback the Board of Trade of Lyons applied to the Central Government in Paris suggesting the amalgamation of the four private

conditioning houses, and by seizing the business to run it as a monopoly under a very close supervision. Consequently, by decree of the 23d Germinal XIII (5th April, 1805) Napoleon I. conferred on the Board of Trade of Lyons the monopoly for the conditioning of silk. The owners of the four private conditioning houses were forced to close and received a small compensation. In 1809 the Board of Trade voted the building of a new plant, and in 1814 the concern was opened for the public service. Until 1842 the method of conditioning remained unchanged.

In 1831 a French engineer, Mr. Léon Talabot, tried to have a new system of conditioning adopted. But it was only after ten years of hard work and by innumerable tests of comparison that he succeeded in 1842 in convincing the Board of Trade and the Central Government of the superiority of his method over the old system. The collaborators of Mr. Léon Talabot were the two constructors Persoz and Rochat.

At first Mr. Talabot had dried out the whole bale of silk by hot air, and then gave to the silk a certain amount of moisture. But the high temperature affected the fibre of the silk and the operation occupied too much time and was too expensive. He had then the idea of building the drying oven on a much smaller scale and instead of drying out the whole bale to use only samples from all parts of the bale. These samples were dried out until a complete state of dryness was obtained, that is to say until the heat had no more influence on the weight of the silk. By means of careful studies, and hundreds of tests followed systematically for years, he had arrived at the conclusion that 10% regain of moisture is the natural specific state or condition of raw silk. Later on the percentage of allowance for regain was raised to 11% which is now the recognized standard throughout the silk trade of the world.

Since 1842 nothing has been changed in this standard of establishing the commercial weight of the raw silk. Only the method of attaining the absolute weight (dry weight) has changed occasionally by using different kinds of heating material, such as charcoal, gas, steam, electricity and others.

Up to 1903 all the systems were in connection with the fact that the high chimney exerted a certain suction power from the ovens into the chimney. But this suction of air was variable and depended on the state of atmosphere, such as hot or cold weather, wind, rain, sunshine, each of these facts influencing the amount of draught in the chimney. All possible means were tried to counterbalance these effects by adopting regulating machinery of different systems, but without absolute success.

Mr. Guisepe Corti, the Manager of the Milan Conditioning House Cooperativa, then conceived the idea, that instead of the suction power of the chimney, a ventilator or blower might be used to force the necessary amount of heated air through the ovens and silk and thus obtain the absolute weight of the silk samples. He constructed the machinery fit for the purpose and had it patented. At the present time all the important Conditioning Houses in Europe have

adopted the Corti System, which means a good step forward, as the conditioning operation has been shortened by nearly one-half, and uniformity of method obtained, which was unknown before. It is also the system adopted by the U. S. Silk Conditioning Company of New York, and to whom we are indebted for this article.

The leading Silk Conditioning Houses in Europe are at the following points:

Italy:—Milan, Turin, Bergamo, Lecco, Como, Florence, Udine, Messina.

France:—Lyons, St. Etienne, St. Chamond, Aubenas, Avignon, Calais, Paris, Marseilles.

Switzerland:—Zurich, Basel.

Germany:—Crefeld, Elberfeld.

Austria:—Vienna.

England:—Bradford.

There are also other cities in Europe where Conditioning Houses exist, but there the testing done is principally on other fibres.

#### Means For Efficiently Controlling The Air Currents In Stock Driers.

The same refers to an improvement in driers in which a plurality of endless aprons convey the stock from the top one through the others and delivers it at the bottom.

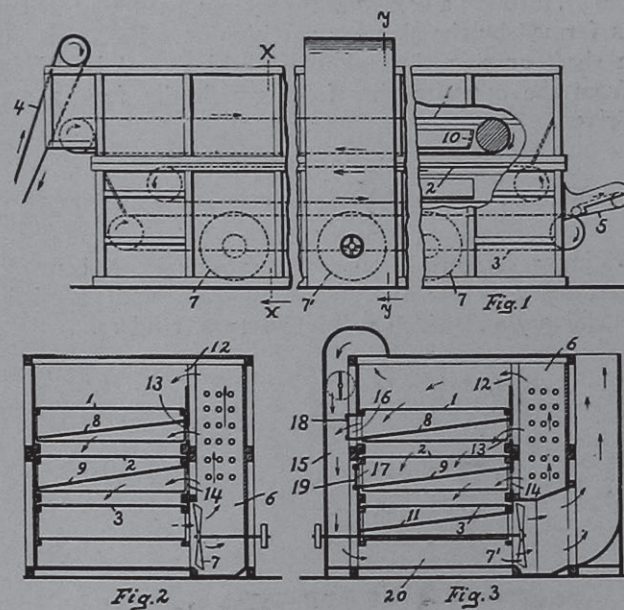

Of the accompanying illustrations, Fig. 1 is a side elevation of such a drier, a portion of its side being shown partly broken away to show its interior, in section. Figs. 2 and 3 are transverse sectional views on the lines x-x and y-y, respectively of Fig. 1.

1, 2 and 3 are the endless aprons, for carrying the moist stock during the drying process; 4 is the feed and 5 the delivery apron, 6 is the heating chamber, 7 and 7' are fans.

In order to control the direction of the air currents in the new construction of a drier, oblique partitions 8 and 9 are placed under each of the top strands of the upper aprons. Partition 8 extends about the whole



length of the apron 1 and terminates in inclined walls 10, to direct the air currents in the proper direction. Partition 9 however, does not extend the full length of the apron 2, so that a space at the end is left for the free circulation of the air, downwardly at its ends. Partition 11 serves as a cover for the outlet box and extends only throughout the width thereof.

**THE AIR CIRCULATES IN THE FOLLOWING WAY:** It is blown in through the openings 12, 13 and 14, on the top of the stock, on each of the aprons. The air circulates down through the stock on these aprons, and divides; part passing into the conduit 15, from which it is discharged from the machine and part circulating along the aprons, or, in the case of the apron 1, passing upwardly into the passage from the upper part of the drying chamber. The part which moves along each of the partitions is discharged from the ends thereof into the compartment below, so as to be circulated over and over again by the fans 7. When it is found that the air discharged has not taken up enough moisture, the openings 16 and 17 are regulated by means of doors 18 and 19 respectively. When they are closed, all the air discharged into the drying chamber below the partition 8 must circulate longitudinally thereof, and be discharged at the ends, where it can be taken up by the fans 7 and circulated again through the machine.

The air is discharged from the drier by means of fan 7', through a box 20 at the bottom, the top of which is formed by the slanting partition 21. Fan 7' is on a shaft passing through the machine, and is driven from the opposite side from which the fans 7 are driven.

#### Roller Delivery for Wool Scouring Machinery.

The accompanying illustration is a diagram illustrating a system of roller delivery for wool scouring machinery as practiced in connection with English machinery and which will interest our readers.

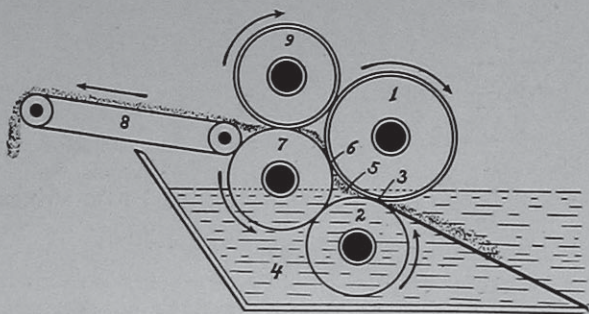

Examining the diagram, we see that rollers 1 and 2 are situated in such a position so as to give to the wool a wet nip at the point 3, consequently the dirt that still remains on the fibres at this stage, is squeezed out under very favorable conditions, because immediately the dirt is squeezed out, the water with which it is surrounded prevents any further adherence to either the fibres or the rollers. The revolution of the roller 2, tends to convey the dirt and sand into the tank 4, and as the water from this tank is constantly being pumped into a settling tank, there is very little danger

of the same collecting. Immediately after the wool has received a wet nip at 3, it is rinsed at the point 5, and should therefore be in comparatively clean state when it becomes subject to the dry nip 6 between rollers 1 and 7. The wool is then delivered to the lattice 8 and from there passes out of the machine; the roller 9 acting as a kind of fan-roller, assisting in conveying the wool to the lattice.

#### TESTING OF CHEMICALS AND SUPPLIES IN TEXTILE MILLS AND DYE WORKS.

(Continued from page 92.)

##### (3) Gravimetric Analysis.

The most important instrument in gravimetric analysis is the chemical balance, a specimen of which is shown in Fig. 2, it being the balance as built by Henry Troemner of Philadelphia.

The chemical balance consists of a central pillar firmly attached to the floor of the enclosing case. Upon the top of the pillar is a plane having a V-shaped crotch, lined with polished steel or agate, in which rests the beam by means of a steel or agate knife edge. At each end of the beam is a steel or agate knife edge from which hangs the frame which carries the scale pans.

On the centre of the beam is fixed a long delicate index needle which swings in front of a graduated ivory scale.

From the right hand side of the balance case extends inward a movable rod, controlled from outside this case by a milled screw head. This rod manipulates a piece of wire, shaped like a clothespin, known as a rider, which can be placed on any point of the graduated beam. The rider usually weighs 10 milligrams. The beam of the balance is divided into 10 main divisions, number 1 being nearest the centre of the beam, number 10 at the end. Each of these main divisions is divided into ten equal parts. The large divisions give the number of milligrams or 0.0001 of a gram and since a gram is approximately  $\frac{1}{30}$ th of an ounce, this balance weighs to  $\frac{1}{300,000}$  of an ounce.

When the balance is not in use, the beam is raised from its agate bearing by a simple mechanism. This is done by turning the milled screw head, shown in the front of the balance, by this raising the beam from its agate bearing, (setting the balance *at rest*) the knife edges are preserved and the balance is kept in good condition. The scale pans are supported by little discs coming from below. These are lowered when weighing, by pressing a button, so that they will not interfere with the scale pans.

At each end of the beam is a very small milled screw head which can be screwed in or out, and by which the beam is balanced. A circular spirit level or two tubular ones at right angles to one another, at the base of the central pillar, will indicate whether the balance sets level or not; the milled screw heads, under the corners of the case, are provided for regulating purposes. The whole mechanism of the balance is contained in a wooden frame with glass on the four sides; both the front and back windows slide up and down.

The workmanship of a fine balance is so delicate, that the greatest care should be used in setting it up and in handling its various parts. Many excellent balances have been ruined or greatly injured by pure carelessness, by striking the knife edges or letting the beam fall suddenly on the central agate bearing, thereby destroying the delicate ground knife edges, and as a consequence, the high sensitiveness of the scale is lost.

THE BALANCE IS SET UP AS FOLLOWS: The hangers (which carry the scale pan) should be placed on the beam so that the marks on each correspond—that is, each hanger has a mark corresponding to one on the knife edge of the beam to which it belongs, and as the hangers are not made interchangeable, correct placing should be observed. Care must also be observed in handling the pointer or needle that it is not bent. Should it scrape against the ivory scale when oscillating, lift off the beam, taking hold of it at the ends, and lay the pointer on a smooth flat surface and gently bend the point downward; then replace the beam and note any improvement. If it still scrapes, remove the beam and repeat the bending until the needle oscillates freely; however, it is not advisable to have the pointer too far away from the scale, as it makes it so much more difficult to read.

The balance is so delicate and sensitive, that great care should be taken in placing it. It should set on a firm foundation so that it will not be shaken by a wagon passing by or by people crossing the floor. It should be placed so that the direct rays of the sun cannot strike it, because the heat of these rays effect the balance when it is being used, so that accurate results cannot be obtained. It should be kept in a room free from acid fumes, and out of moist atmosphere, because the fumes and moisture will attack the metal parts. Danger from moist atmosphere can be partly overcome by having a small vessel (an eight ounce wide neck bottle) half filled with concentrated sulphuric acid, placed in one of the back corners of the case. The sulphuric acid does not give off any fumes, and absorbs the moisture in the air. Every year the old sulphuric acid should be replaced with fresh acid.

By means of the spirit levels, and the set screws under the corners of the case, the balance can be placed in a state of perfect equilibrium, and it should always be kept in such a state. To determine whether it is in adjustment, turn gradually the milled head which raises the beam off the support, and then push the button of the rod which supports the scale pans.

The needle should go to the same distance on either side, less a small fraction, due to decreasing momentum. If it does, the balance is in equilibrium; if it does not, the difference is adjusted by means of the screws at the ends of the beam. After the balance is once set up, the scale pans or beam should not be touched with the fingers. This is especially true immediately before weighing.

WEIGHTS. The larger weights (that is those of 1 gram and over) are made of brass. The box of weights contains one 10, two 5, one 2, and three 1 gram weights. The smaller weights are made of thin sheets of platinum, or aluminum with one corner turned up

so that they can be picked up readily with a pair of pincers. Remember, never touch the weight with the fingers, use the pincers which come with the weights. The smaller weights are generally arranged as follows:

one—	.5	gram or 500 milligram
two—	.2	“ “ 200 “
one—	.1	“ “ 100 “
one—	.05	“ “ 50 “
two—	.02	“ “ 20 “
one—	.01	“ “ 10 “
one—	.005	“ “ 5 “
two—	.002	“ “ 2 “
one—	.001	“ “ 1 “

The two last mentioned weights are in the form of wire because discs are too small.

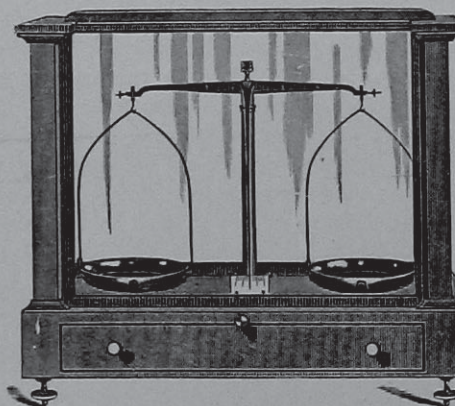

FIG. 2

HOW TO WEIGH. The scale pans are first brushed off with a small clean dry camel's hair brush. This brush should be used for this purpose only. The resting or zero point of the balance must be first determined; the beam is moved from its supports by slowly turning the milled drum head in the front of the balance as far as it will go, (then this drum head will not have to be held during the weighing) the button which moves the scale pan supports, is pressed with the left hand and held in that position. The beam now moves slightly, this is shown by the pointer on the ivory scale. The pointer is allowed to swing once to the right and once to the left or vice versa. The number of divisions it swings to one side of the centre is noted, then the number of divisions on the other side, and then the number of divisions it swings on the first side is read. The readings are made in the following manner: The centre point is 0. The divisions to the right are 1, 2, etc., the divisions to the left are—1—2, etc. Each of these main divisions are divided approximately by the person who is weighing, into 10 parts, so that half a division is read as .5, etc.

Suppose the balance swings 3.5 division to the right and 3.2 to the left and 3.4 to the right again, then we add the two readings on the one side and get their average:  $3.5 + 3.4 = 6.9$  or average 3.4 to the right. The pointer has swung 3.2 division to the left; the average of the right and left reading are then made:  $3.4 - 3.2 = 0.2$ . Divide this by 2, we get 0.1. The resting point of the beam thus is 0.1 of one division to the right.