

to use a reed hook for drawing in the warp threads in the reed, as now universally in use.

Diagram Fig. 5 is given to illustrate the construction and threading of the new reed, the illustration being a vertical sectional view through the lay and the new reed of a loom.

This illustration at once shows the complete invention, *i. e.*, that the upper portion of the reed can be swung away from the hand rail of the loom, so that the warp threads may be readily dropped into the spaces between the dents.

ANOTHER ARRANGEMENT for drawing threads more or less automatically in the dents of a reed is shown in Diagram Fig. 6; the invention being by the same parties as the one previously explained, and consists of a plurality of rotary disks 1, situated partially within the space between the dents 2 of the reed. These disks are mounted on a rod 3, which extends across the loom and is located directly back of the reed.

If it is desired to draw a warp thread through any space of the reed, the thread is put into one of the slits 4, in the threading disk 1, which occupies the said space, and then said disk is turned, thereby carrying the slit having the thread therein, through the space, onto the front side of the reed. If it is desired to draw a plurality of warp threads through the reed, said warp threads are placed in the slits of the proper threading disks and then all said disks turned, thereby drawing all the threads through the reed at one turning operation.

PRACTICAL POINTS ON NARROW WARE LOOMS.

By E. P. Woodward, *Master Weaver*.

Of the narrow ware looms in use to-day, none are doing a greater variety of weaving, so far as stock, design, and fabric structures are concerned, than the narrow ware looms built by the well known Crompton & Knowles Loom Works.

Their narrow ware weaving machinery includes looms of all types, for producing narrow ware goods, of all descriptions, from the coarsest sisal twine used for both warp and filling to the finest silk.

In every instance it will be found the object of the builder has been to construct as simple a machine as the class of goods for which it is designed will permit.

To illustrate: Their looms for weaving webbing such as is used for girths, halters or head stalls and flat and tubular fabrics of that class, are machines so simple and substantially built that when once rightly set up they will almost take care of themselves. This is accounted for more readily because *every motion of the loom is positive*.

The shuttles are operated by a rack and pinion gear drive common to all their tape and narrow ware looms.

The shedding device consists of side cams and their levers, to which the harnesses are fastened by means of suitable strapping.

Beam stands of strong and suitable construction take care of the different warps required, *i. e.*, ground, stuffer and binder warps.

A convenient and positive take up motion finishes the loom, resulting in a loom which is ready and capable of giving a good account of itself anywhere it runs.

Another type of narrow ware loom is that for weaving Mexican sisal and such twine into different width fabrics. Generally the sisal twine is used for warp as well as filling. These looms are built in different widths and with shuttles to suit the loom's construction.

The shuttle drive is of the rack and pinion gear style, actuated by a switch. The loom is heavily constructed to stand the heavy work required of it. The harnesses are operated by means of heavy side cams and levers and the shuttles are large, so as to carry as much filling as possible. Looms of this type are used for weaving flat as well as tubular goods.

The warp, consisting of heavy sisal twine, is put up in a rack, one end to each spool, and these ends are passed around a friction or tension drum and from there all enter the reed at the same tension.

Since in an average only about eight picks per inch are used in the construction of these fabrics, it will be readily seen that these looms produce plenty of fabric. These goods are used in many places for girths, cinches, bands, etc., and take the place of cotton webbing and leather girths for pack mules. Looms of this type have been running in Yucatan for some years, giving good satisfaction although operated by decidedly unskilled labor.

From these looms of a very simple construction, one may pass to the more complicated narrow ware looms of different construction and yet all embodying the same general principle or method of moving the shuttles, *i. e.*, by the sliding rack and pinion gear.

Here one can see a loom built to carry many shuttles and to use almost any type of shuttle the purchaser may call for.

The common equipment would probably be a straight shuttle and single bank lay. When desired, looms are fitted with two banks of shuttles for weaving one fabric above the other and combining them by means of a pile warp as when making plushes.

The shuttle drive can be arranged to drive all the shuttles of both banks in the same direction at once, commonly called straight drive, or they can be arranged to drive one bank in one direction and the other bank in the opposite direction or *cross-shot*. This latter drive has the advantages of tending to balance the momentum perhaps and it is much more convenient for the weaver to change shuttles as it is possible to stop the loom in such a position as to leave the lower bank of shuttles where they are free from *cover* by the upper bank and the filling at this point can be readily changed.

Looms for velvet ribbon weaving are equipped with the Knowles-Head when desired, which makes an *Ideal Shedding Device* for the work.

When lighter work is contemplated, the looms quite often can be fitted with a suitable dobby head. The dobby heads are very well suited to the handling of fine silk and cotton warps and impart a very slow

and steady motion to the harnesses throughout their entire change, in fact the dobbie gives about the limit of time in which a shuttle can safely travel through the shed.

Looms so far described have been of the one or two bank type with the shuttles maintaining a fixed position to the shed through which they pass. With such looms, it is possible to put but one kind of filling in the shed without changing the bobbin.

For weaving fabrics which require different fillings the lay fitted with three or four banks (drop shuttle) is used. These shuttles can be raised or lowered by a suitable device in order to bring any shuttle in position to pass through the shed at any desired pick.

With this loom, colors in both warp and filling can be handled in the same manner as in a full fancy drop box loom.

In this article some types of narrow ware looms of to-day have been briefly described. Details of construction or adjustments have not been treated. All of these machines have been described in their simpler forms. There are many devices which can be used upon them and all are designed for some special purpose.

What some of these devices are, and for what purpose they are constructed for, will be dealt with later on.

(To be continued.)

SILK FROM FIBER TO FABRIC.

(Continued from page 71.)

A rather important silk spinner of India is the *Anth. Assama* or *Muga Silkworm*, which is met with half-raised (*i. e.*, raised in the open air) in Assam, Darrong, Lakhimpore, Dhurumpore, Dehra-doon. In its fully wild state this worm is found in Katschar.

Muga means *amber*, the name being given to the cocoon on account of its yellow color. This silkworm thrives on different plants, the ones preferred being *sum*, *sunalu*, *tschampha*, *T. diglottica*, etc.

The bright colored Muga silk as is raised upon the *tschampha* is of the best of quality and fineness and carries the name *tschampha pattea muga*, it being a quality of silk exclusively worn by Rajahs and other men of prominence in India.

The second best quality is the so called *Maizankuria* or *Adda-Kurry* indicating the name of the plants upon which they thrive. The finest quality of the second variety is the so called *Soom-silk*, which is a beautiful fawn colored fiber; inferior brown sorts being *Soonhalloo* and *Digluttee*, and finally the *Patees hoonda*, a muga specie feeding upon the mulberry tree.

Anth. Assama produces from 3 to 5 generations a year, every harvest having its own name, and which adheres to the lot of silk thus produced. Fall and Winter harvests (October and February) *Katia* and *Dscharua* are the richest ones in quantity of silk produced, whereas the other harvests produce the best in quality. The dimensions of the cocoon are 50 by 25 mm, of egg shape, and possess a small hole, and are of a yellow, gray, red or white color. They are hard

to reel-off, yet at the same time, after disintegrating with potash solution (vegetable ash) are extensively



ANTH. ASSAMA—WORM.

pulled and spun. One thousand cocoons furnish about 220 g silk. Muga silk furnishes an extensive export



ANTH. ASSAMA—COCOON.

article of Assam, leaving this province of India mostly in the shape of hanks. Fabrics made from muga silk



ANTH. ASSAMA—MOTH.

will withstand washing superior to such as made from mulberry silk, retaining their lustre completely, the

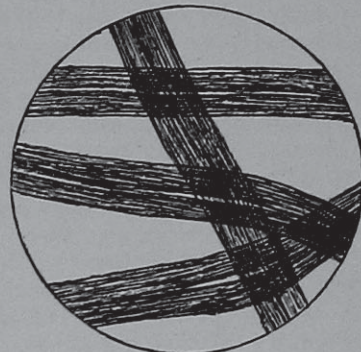

ANTH. ASSAMA—FIBRES MAGNIFIED.

thread being of astonishing strength. Muga cocoons are well suited for the manufacture of spun (fancy) yarns. In its structure, muga silk resembles tussah,

Posselt's Textile Journal

A Monthly Journal of the Textile Industries

PUBLISHED MONTHLY BY

E. A. POSSELT, 2028 BERKS STREET,
PHILADELPHIA, PA.

SUBSCRIPTION RATES:

United States and Mexico, \$2.00 per year.

Canada, \$2.50 per year.

Other countries in the Postal Union, \$3.00 per year.

Single Copies, 25 cents.

This Journal is published on the tenth of each month.

Postage prepaid by the Publisher.

Subscriptions begin with the number following the date on which the subscription is received at this office.

In writing about subscriptions, always give your full name and address.

When writing for changes in address, always give the old address as well as the new address to which copies are to be sent.

Money should not be paid to agents or solicitors unless they can show authority from this office. This Journal cannot be responsible for money paid to unauthorized persons.

Subscriptions are payable in advance. Money can be sent by check, draft, money order or in registered letter. Make all drafts, checks, money orders, etc., payable to E. A. POSSELT, Publisher, 2028 Berks Street, Philadelphia, Pa.

ADVERTISING RATES ON APPLICATION.

COPY FOR ADVERTISEMENTS must reach this office not later than the 25th of month preceding date of issue, to insure proper attention.

ALL COMMUNICATIONS WILL BE CONSIDERED AS CONFIDENTIAL.

Letters to receive attention must be accompanied by the signature of the sender, but this will not be published unless so requested.

We will always be glad to receive articles of a practical nature relating to the textile industries, and will publish such as are available.

EUROPEAN AGENTS: Sampson Low Marston & Co., Ltd., 100 Southwark Street, London, S E., England.

however takes mordants and dyestuffs easier than either tussah or eria silk, in fact in that respect closely resembles true mulberry silk.

Anth. Mezankooria is a native of British-Burmah and Assam, producing a most beautiful grayish white silk, of a considerable higher lustre than the best qualities of muga silk, and for which reason the same is preferred by the natives. The value of *Mezankooria* silk is 50% more than that of muga silk. With reference to dyeing, it acts the same as true mulberry silk.

Telea Polyphemus is the representative silk spinner of our country. The original color of this silk-worm is white, but which changes gradually to a greenish shade. The worm feeds chiefly on oak leaves, and produces a white or fawn colored cocoon, of a round shape and rich in silk, and in its character closely resembles tussah. The size of the cocoon is 40 by 25 mm.

Anth. Bauhinia is a native of Senegambia, producing a gray colored cocoon about 45 by 25 mm in size, and 80 cg in weight, the cocoons being sometimes open. The fibre obtained is a most beautiful, lustrous, pink colored, valuable silk.

(To be continued.)

We are pleased to announce that Mr. H. P. Page has associated himself with us as Business Manager of the Journal. He is a practical Textile man, knows the trade personally, having been formerly connected with Joseph R. Forster and Sons of Philadelphia, leaving them to accept the Secretaryship of the Philadelphia Mercerizing Co.

Mr. Page will give his undivided attention to the outside business of the Journal, doing everything in his power to increase its efficiency and value to all interested in the textile trade.

NATIONAL ASSOCIATION OF COTTON MANUFACTURERS.

The eighty-sixth annual meeting of the National Association of Cotton Manufacturers was held April 28 and 29, in Talbot Hall, Mechanics' Building, Boston.

An exhibit of mill supplies and textile machinery, held in the same building, was attracting a great deal of attention.

It was expected that Prof. A. Lawrence Lowell, who will succeed President Eliot of Harvard, and President-elect MacLaurin of the Massachusetts Institute of Technology, would address the convention, but they were unable to attend.

President Plunkett called the association to order shortly after 11 o'clock, April 28, and disposed of the usual business preliminaries before calling for the formal addresses.

The association medal was awarded to James R. MacColl, secretary and treasurer of the Lorraine Manufacturing Company of Pawtucket, R. I., being thus rewarded for his paper last year on "The International Relation Between Cotton Manufacturers."

His Excellency, Eben S. Draper, the popular Governor of Massachusetts, and who is a Member of the Association, then welcomed the Delegates on behalf of the State of Massachusetts. He expressed his great pleasure in being a member of this association and congratulated the manufacturers upon the fact that they were sure of the maintenance of a protective tariff and of a new era of prosperity as soon as the schedules were finally enacted.

In response to the Governor's address, Vice President Hobbs complimented the Association on the fact that at last, after 125 years of waiting, the Governor of this Commonwealth is a man connected with the Cotton Industry. *Governor Draper*, he said, *is the first man of that industry to occupy the Governor's chair in Massachusetts, and he is a most able representative.*

President Plunkett then read his annual address. He was followed by Colonel Clarke, secretary of the Home Market Club, who discussed "The Importance of Outside Conditions."

Prof. George F. Swain, L.L.D., was then introduced and addressed the convention on the subject "Conservation."

One of the strong points of these meetings of the Association are the reading of papers on subjects of interest to its members and of which thirteen were read during the second, third and fourth session. Amongst those of more than passing interest was

SEMI-COMBING by Mr. Elwin Holbrook Rooney, of Whitinsville, Mass. The definition of the word semi-combing will give an idea of the scope of the paper, said definition being: "*A method of obtaining a high production in a cardroom; one thousand (1,000) pounds per week of semi-combed work, with only about eight (8) per cent noils.*"

It will thus be seen that in the process of semi-combing, which includes carding and combing, the loss in waste is not greater than in the method of double carding. By semi-combing, the spinner is enabled to increase the production of his card from 25 to 50% above what he could produce in double carding and the result is that, by the process of combing instead of carding, he removes the shorter fibres from his cotton, (which he could not do by the use of the second process of carding) arriving at a *finer, rounder, stronger thread*, which can be spun with *less twist*, giving him a *greater production* with the same break; or if spun with the same twist, he will get an *increased breaking strength*; from 10 to 15% on 36's yarn.

The principal events of the afternoon session, April 29th, were the election of officers and the adoption of resolutions. The committee on officers for the ensuing year reported in favor of the old board and they were unanimously chosen as follows: President, Chas. T. Plunkett, of Adams; vice-presidents, Geo. Otis Draper, of New York, and Franklin W. Hobbs, of Boston; directors for three years, Geo. P. Grant, Jr., of Fitchburg; Edwin Farnham Greene, of Boston, and David S. Johnston, of Cohoes. C. J. H. Woodbury was re-elected as secretary and treasurer.

The board of managers of the Silk Association of America, at a special meeting April 15th, elected Mr. Jacques Huber as secretary of the organization in succession to Colonel Franklin Allen. Mr. Huber is well known here and abroad as a member of the firm of Swarzenbach, Huber & Co.

Mr. Ramsay Pequet, the well known Silk Expert of New York, formerly with Hogue & Co., was chosen as assistant secretary, and much of the work formerly performed by Colonel Allen will fall to his lot.

The meeting was presided over by Vice President Jerome Read, of the Read & Lovatt Manufacturing Co., in the absence of President Skinner.

Mr. Allen was the first secretary of the Silk Association, having been elected at its first meeting in May, 1872, and his active and conscientious labors during the succeeding five years were an important factor during those formative days of the association.

He became secretary again in 1898.

The Annual Convention of the National Association of Hosiery and Underwear Manufacturers is held in Philadelphia during this week—May 11 to 13. Sessions of the Association are held in the Continental Hotel, an exhibit of supplies and machinery being located at 921 Walnut Street. Mr. C. B. Carter is the Secretary-Treasurer of the Association, with offices at 683-5 Drexel Building, Philadelphia.

President Finley, of the Southern Railway, on returning from a trip through the South is responsible for the statement that business in the South is gradually recovering from the depression which began in the fall of 1907. East of the Mississippi River, conditions for cotton planting seem to be about normal. Reports from some quarters indicate that farmers are reducing their cotton acreage slightly and are giving more attention to other crops. There has been an improvement in both the domestic and export demand for cotton mill products.

To uphold his statement of the South recovering from the depression of the last two years, Mr. Finley mentions that his railroad has been able to resume work on improvements, in double tracking, revision of grades, etc., etc., all of which had been suspended during the depression, the company at the same time having placed orders for considerable new passenger rolling stock, also such as destined for express, baggage and mail service.

Textile industries in New England are feeling the wave of prosperity coming and mill stocks are quoted at higher prices. About \$20,000,000 of construction has already been undertaken by nearly forty mill corporations, some spending from \$200,000 to \$3,000,000 each. Most of the total expenditures are in Massachusetts.

Four large new plants to cost more than \$7,000,000 are under way. The largest of them being the Ayer mill of the American Woolen Co., the new Arlington mill, and the New Bedford Mill Corporation.

That a combination of silk industries in Southern France, representing \$10,000,000 of capital, will transfer their plants to this country was stated by Jean Duplan, head of a large silk dye works at Hazleton, Pa., April 15th, when Mr. Duplan, accompanied by D. A. Gillet, a French silk manufacturer, who has been investigating conditions in this country, sailed for Havre. Some time ago Mr. Duplan was empowered by various silk manufacturers of France to look the ground over in this country for the purpose of ascertaining the expense which would attach to the establishment of large silk plants here.

As a result of his investigation, he said, it is possible that a considerable part of the silk manufacturing properties of Southern France will be transferred to this country. Because of the tariff now in effect, he said, it would be more profitable for the French manufacturers to turn out their product on this side.

Every manufacturer of Carded Woolen Goods in this country has received a letter written by Gordon Dobson, President of the Maine Woolen Manufacturers' Association, and a prominent woolen goods manufacturer of Pittsfield, Me., calling upon this industry to organize at once for the purpose of obtaining the legislative recognition to which carded woolen goods manufacturers are entitled, and thus put them upon more equal terms with worsted manufacturers, which are organized.

Duckworth's Patent Traveler Magazine.

Travelers are a great expense in connection with ring spinning, amounting to about \$20.00 per thousand spindles the first year in connection with a new ring frame, after which, there will remain always an expense of from \$6.00 to \$8.00 per thousand spindles per year. New rings will always wear out travelers quicker. One method of economizing in the amount of travelers needed by the mill is to have the speed of the spindles, and the weight of the travelers, so proportioned that the travelers will not heat up and consequently lose their temper, wearing out and flying off.

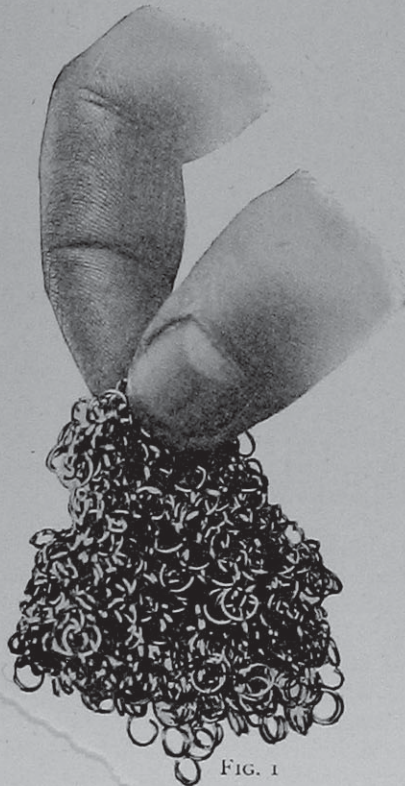

FIG. 1

Another item to save travelers, is to provide suitable holders and have them arranged conveniently so that the spinners will have no occasion to carry the travelers around in their mouths or pockets or leave them loose on thread boards or creel boards, to be in turn brushed off on to the floor.

Travelers have a faculty of bunching together as shown in illustration Fig. 1, so that it is difficult, if not impossible, to separate them without loss.

The Duckworth Traveler Magazine, shown in its perspective view in Fig. 2, obviates this disadvantage, takes a bunch of the travelers, and in regular operation drops them singly on a plate provided for this purpose to the magazine, so that there is no excuse for losing travelers in handling.

A comparison of the two illustrations tells the whole story. The magazine will pay for itself in a very short time, its price being only \$1.00, additional cylinders, 25c each.

For a description of the working mechanism of

this Traveler Magazine, see pages 181 and 182 of the December issue of the Journal.

COTTON SPINNING.

The Ring Frame.

(Continued from page 107.)

Ring Travelers.—On the spinning ring is placed the traveler, a small steel clip sprung over the upper flange of the ring, resting afterwards loosely upon it and being capable to be made to slide easily around on said flange of the ring. To illustrate the subject, Figs. 266 and 267 are given, and when *A* shows the traveler, and *B* the upper flange of a double flange ring. Fig. 267 shows how the traveler is sprung on the flange of its ring *i. e.*, the amount of clearance

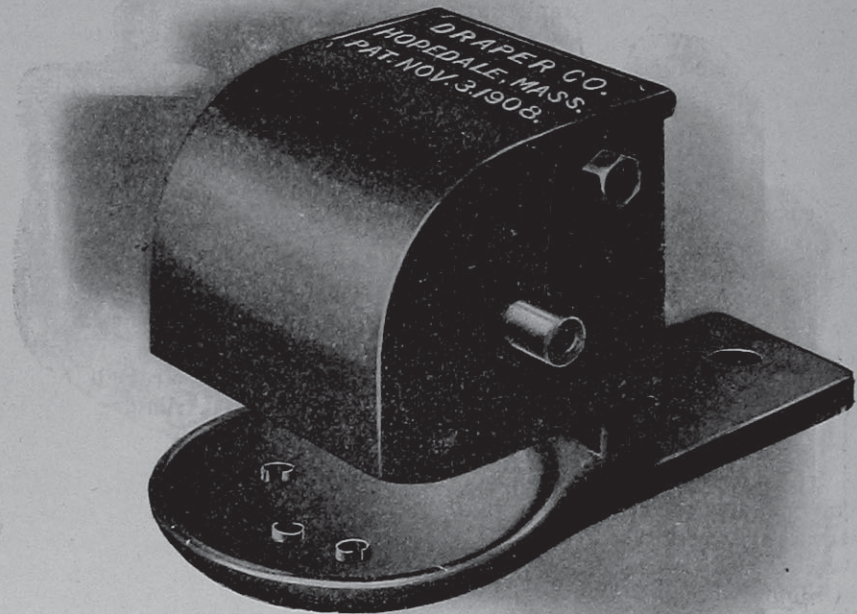

FIG. 2

(see dotted line *C*) it has to overcome in being sprung on, this being at the same time the amount of clearance that prevents it from flying off its ring during its rapid revolution around the latter in the process of spinning.

The traveler receives its motion by being dragged, by the yarn, around the flange of its ring; the yarn in its passage from the pair of front drafting rolls to the bobbin, turning at an angle at the point where it passes through the traveler. For this reason it will be seen that all the twist in the yarn is introduced between the traveler and the pair of front drafting rolls. The revolution of the traveler resembles the action of the flyer on our fly frames. The latter is then driven at a constant speed by spindle, while the bobbin is driven by a positive mechanism at a faster speed, so as to wind up the roving on the bobbin. In the ring frame, spindle and bobbin revolve at a constant speed together. The yarn, as coming from the front drafting rolls, in turn passes through the traveler on its way to the bobbin, the traveler being

dragged by the yarn around with the bobbin, but does not go quite so fast. This lagging back of the traveler is equivalent to a bobbin lead, and allows yarn to wind on bobbin, at the same time, the revolving of the traveler on its spinning ring being the cause of twist in the yarn.

A ring traveler, although the smallest device in use in a cotton spinning mill, plays a most important part. It performs a double duty, for it not only winds the yarn on the bobbin, but at the same time, on account of the revolution of the spindle, introduces the twist into the yarn as well. When one takes into consideration the average speed the traveler runs, *i. e.*, the distance it has to travel in a given time, it will be rather astonishing to quote, that, running at a speed of about 50 miles an hour, the entire circumference of the earth (about 25,000 miles) would be covered in this way in less than 21 days.

The primary function of the traveler, however, is to wind the yarn on the bobbin. As the traveler is drawn around the ring by the rotation of the thread, the more slowly the traveler moves (considering no change in speed of spindle) the more tightly the yarn is wound on the bobbin. The rate of speed of the traveler depends on its size, and that depends on the counts of the yarn spun; the rule being, that the coarser the count of the yarn spun, the heavier the traveler used must be. If the traveler used is too heavy in weight for the count of yarn spun, it will drag or move more slowly than the normal requirements, with the result that the percentage of broken threads will be increased, due to the extra weight of the traveler. In the same way the drag will be increased, to the injury of the yarn spun, provided the ring is not true, or the traveler worn or defective. Worn travelers have a bad effect on the yarn, more particularly so when dealing with rather low counts of yarn. On higher counts of yarn, travelers will break just as soon as they are worn, hence need less attention. In connection with medium or coarse counts, travelers should be changed at stated intervals.

Some spinners change travelers throughout at stated intervals, about every 5 or 6 weeks, whereas the better plan is to detect worn out travelers and remove them individually. This will secure an even draft and besides save in travelers, about one-third less will be needed. The spinners are taught to feel of the traveler every time they piece up an end, by putting their forefinger inside the ring on the traveler and the thumb on the outside of the ring; then by moving their forefinger to the left, they will detect at once any roughness or sharpness on the right hand side of the traveler, which is where the wear chiefly occurs. Care should be taken that the proper size of traveler is put on, and that different sizes of travelers do not get mixed with each other.

Good travelers are a necessity to good spinning. They should positively fit the rings, be adapted to the counts of the yarn to be spun, be of the proper shape and made of the best material. There are a number of shapes, some of which are preferred on account of

giving a more even tension to the yarn. It is a good plan to order your travelers always, if possible, from the same firm, because in time you will get acquainted with them, how they run and are numbered, and what kind is best for certain counts and qualities of yarn you are spinning, or are to spin; whereas if you are to use a traveler not accustomed to, the chances are that you will have to change two or three times before getting the right number. The traveler that does not clog up with lint and thus runs more easily, should be preferred.

Travelers, while in operation, will collect and carry with it fine fibres or lint, thus are liable to change their weight and consequent tension given to the yarn. These fibres which adhere to the traveler

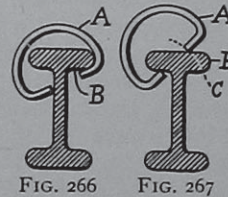

while revolving, are liable to either break the thread when the mass becomes large, or fly off and into the yarn. This clogging occasions considerable loss of time to the spinner and it increases the wear and tear of the traveler. To remedy this evil is the purpose of the traveler cleaner, as explained in a previous chapter. By the application of this cleaner, there is much less friction exerted upon the traveler, and consequently there is a saving in the wear of travelers, besides an increase of production, smoother and better yarn spun.

THE ACTION OF THE TRAVELER.

The size and weight of the traveler to be used depends upon the counts of the yarn spun, since the revolutions of the traveler must lag behind the revolutions of the spindle, *i. e.*, the bobbin, sufficiently to maintain proper tension on the yarn, so as to wind on the bobbin the length of yarn delivered by the front drafting roll, minus the contraction, imparted to the yarn on account of the twist. Here, considering more particularly, for sake of simplicity, the warp winding system, we have the problem of winding continuously delivered yarn (by the pair of front drafting rolls) on a revolving cylinder (the bobbin). As mentioned before, the yarn passes under an acute angle under the traveler, on its way to the bobbin, its pull upon the traveler revolving the latter. The same as with the winding problem in fly frames, if the guide eye of the presser foot, *i. e.*, the traveler in this case, would revolve at the same speed as the bobbin, no yarn could be wound, for which reason the same as on roving frames, there must be some difference between their speeds. Since the traveler is not driven positively, as is the flyer in the fly frames, but is pulled around by the tension of the yarn, it cannot be made to go faster than the bobbin, hence the only chance left open for it, is to have it lag behind the bobbin, although if considered from the point of a problem of winding, it would make no difference which of the

two runs the faster, and the only point necessary would be that the difference be a known one.

This will explain that since the speed of the spindle (bobbin) is a constant one, that the smaller the diameter of the bobbin, the more revolutions of the traveler are necessary to wind the same length of yarn, then when bobbin gets fuller; the extreme points between the number of revolutions being the empty and the full bobbin. It is evident thus that the tension upon the yarn, as exerted by the traveler, must gradually become less as the bobbin builds itself up, *i. e.*, becomes larger, in order to regulate the winding on of the yarn to the changing diameter of bobbin, so as to take up the constant delivery of yarn fed by the drafting rolls. From this it will be seen that the traveler regulates the twist, *i. e.*, that the speed of the traveler determines the number of turns per inch inserted in the yarn in a given length of it.

There will be always a dispute among practical men whether the spindle or the traveler puts in the twist, to which we have to admit that it is the latter, depending, however, upon the revolution of the spindle for its own revolution, hence the chance for difference in opinion. This assertion can be readily demonstrated. For example, consider drafting rolls stationary and a piece of yarn tied to the traveler at one end, and held by the rolls at its other end, and when, considering spindle absent, if then by any means the traveler could be made to revolve around the ring, twist would be inserted in the yarn, the same as if spindle were present, thus demonstrating that actually the traveler and not the spindle puts the twist in the yarn. However, if considering the traveler as a fixed guide to its bobbin, the revolution of the spindle (and bobbin) would carry the traveler around with it, and no winding would take place, but at the same time every revolution of the spindle would put a turn of twist in the piece of yarn. This will explain that it is the combination of these two problems which are required for ring spinning, the traveler being made to act as a guide to wind the yarn onto the bobbin, rotating at the same time quickly enough to put the required turns of twist per inch in the yarn.

(To be continued.)

The Sizing of Colored Yarns.

The sizing of these yarns for weaving is a most important process for cotton manufacturers. If subjected to an abnormal heat, possibly a boiling of the size, the color of the yarn is liable to either run, fade or become dulled. If using two or more colors in the warp, sizing may be the cause of one color staining the other. A fading of the colors will be more readily noticed in connection with light colors. Any one of the defects referred to, will influence the market value of the goods made from such yarns, hence the importance of the proper process of sizing colored yarns, to cotton mills.

In connection with large orders, for a certain style, such are sized on the slasher, as was explained on pages 227 to 229 of the March 1908 issue. However, such large orders for one style are not always met

with, orders for a few pieces of one style only being frequently received nowadays by a mill, in fact orders for one or two pieces only may now and then come in. In such cases, the mill then resorts to the sizing of the yarn in hanks, and when most of the trouble previously referred to is overcome.

Given suitable machines and the necessary conveniences, says the Textile Recorder, the advantages realized are shown in the saving of size liquors and the retention of the brightness of the colored yarn. Each lot, no matter how small, may be finished by itself. Each lot, if well sized, will work in weaving most satisfactorily.

The mechanical contrivances available for carrying out the sizing of hank yarns for such small lots comprise the old-fashioned *stick and peg*, which, in the hands of an experienced workman may still be relied upon to give good results; the starch box with rotary hooks attached over it; and recently many more or less complicated machines.

Passing in review these styles of working, it must be granted that the first-named and oldest method is, in the hands of most workpeople, the least satisfactory. Bare places and uneven sizing, due to uneven squeezing or wringing out, are very difficult to avoid.

The same complaint, but in a somewhat lesser degree, may be laid against the starch box, carrying on one side a stationary hook and on the other, a rotary hook.

Warps made from yarns sized by either of these methods do not conduct themselves in the best possible manner during weaving, and the faulty sizing becomes painfully apparent in the finished cloth. These remarks point to the features that should be present in any yarn sizing machine which shall be efficient. Regular expression of the surplus size carried by the yarn must be provided for.

A machine which has for a long time proved most effectual in actual and continual practice finds much favor on the Continent. The idea expressed in its arrangement is based on the principle that the yarn should be first evenly impregnated with the sizing liquor, and at once nipped by passing between two rubber-covered rollers, and later by a series of four similarly covered rollers. For this purpose a couple of elliptical-shaped rollers are in position directly over the sizing trough; the uppermost of these two, lifted high, carries the yarn. The top roller, when lowered, admits of the yarn engaging with the second roller, and the two draw the yarn evenly through the liquor in the size trough, simultaneously pressing the size closely into the threads. This arrangement naturally lends itself to different ways of working. Instead of the yarn being continually in motion during impregnation with the size, it may be allowed to steep for a few minutes before squeezing. Any way, after sizing, the top roller is raised, the wet yarn lifted from the undermost roller, and spread out flat by hand, and caused to pass through the other rollers carrying suitable pressure, from whence the yarn falls out behind into a suitable receptacle. Here it may lie for about half an hour. The yarn is then taken and placed on

a wooden arm and well shaken with sticks by hand, and arranged for drying.

The yarn prepared in this manner does not require brushing out as by the older methods, although there are, of course, some classes of yarns which may be none the worse for brushing out before drying. The provision of a suitable brushing machine for this purpose is a simple matter. A circular brush is found to give very satisfactory results, indeed greatly relied upon by many firms producing specialties in the way of yarns and threads. The advantages of this form of sizing and brushing apply in degree to yarns intended for the warp of cloths, especially for fine satins, brocades and delicately constructed blouse cloths.

WOOL SCOURING AND DRYING.

(Continued from page 117.)

THE MODEL D, PARALLEL RAKE WOOL SCOURING MACHINE.

The same is shown in Fig. 6 in its perspective view; Fig. 7 is a cross section of bowl, and Fig. 8 a section through Settling Tank, taken on line x—x.

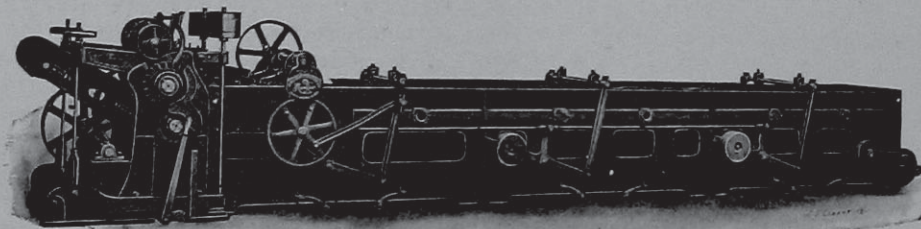

FIG. 6.

The wool is sometimes (in smaller mills) fed to the machine by hand, an endless traveling apron being then placed at the feeding end of the first bowl, whereas in larger mills an automatic self-feed is used for doing this work, the wool in this case dropping directly into the scouring liquor in the first bowl, and when it is submerged by perforated duckers, a hollow rectangular basket of sheet copper with perforated bottom.

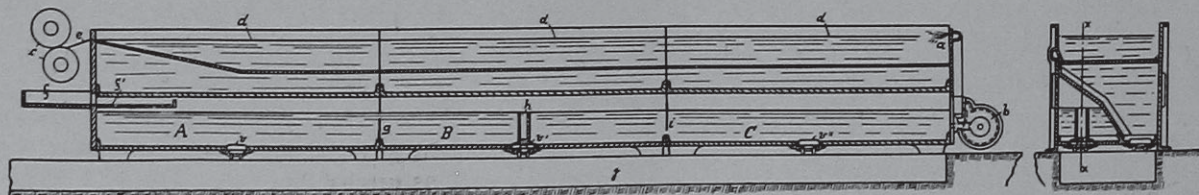

FIG. 8.

FIG. 7.

The wool is then carried forward by a current of liquor (a) supplied by a pump (b) through the feed end of bowl, and in turn passes through the bowl by the action of the teeth of the rake, attached to the rails by means of rake heads.

It is the motion imparted to the rake from which the machine gets its name *Parallel Rake*, said motion at the same time being the advantage of this machine over other systems, imparting to the wool under treatment as little agitation in its travel through the bowl

as possible; however handling it at the same time in such a way that it gets the full benefit of the scouring operation. Although this is an advantage to all classes of wools, it is more particular an extra strong point in favor, when dealing with long staple wools—combing wools.

“Parallel Acting,” or “Parallel Moving Rake,” without question would be a more definite name for this scouring machine, based on the fact that the tips of the teeth of said rake, while in the bowl, move parallel (one quarter of an inch apart) with the perforated false bottom of the bowl.

The length of the rake depends on the size of the machine, its weight being counterbalanced by suitably arranged lever weighting.

The motion of the rake is thus: Descending by suitably arranged crank and lever motion vertically into the liquor (or bowl) until the tips of the teeth of the rake are within $\frac{1}{4}$ inch of the false bottom, and when its teeth then move for about 14 inches parallel with said false bottom, after which they then rise again vertically out of the liquor and travel then above the liquor line (this time in an arc like travel) back to its

starting point; certainly an ideal motion for as little agitation to the wool under operation as is possible, in turn preventing any chance for roping, felting or stringing of the wool.

The wool is thus, by the action of the teeth of the rake, carried along the entire length of the bowl through the scouring liquor, until arriving at the carrier, which in turn delivers it to the bite of the squeeze rolls (c), the stock being wholly submerged in the

liquor from the time it enters the bowl until entering between the squeeze rolls. From there the wool is then delivered in a continuous web, by the doffer-apron, to the next bowl of the train of machines as used.

The last machine in the train, delivers the scoured wool in a continuous web, either into a truck in which it is carted to the dryer or the dyehouse, as the case may be, or the stock is delivered into a conveying apron, which automatically carries it into the self feed of the dryer.

The carrier, as delivers the stock from the bowl to the squeeze rolls, is an arrangement of bronze fingers, or forks, which have a forward and backward motion. The first carries the wool ahead over a perforated brass table so as to bring it within reach of the pair of squeeze rolls *c*, whereas the backward motion lifts the fingers of the carrier clear of the web of wool until it arrives at its initial position, descends, and moves ahead with a fresh supply, so as to keep up the continuous web of wool, delivered by the machine.

The level (*d*) of the liquor in the scouring bowl is kept three inches from the top, *i. e.*, somewhat higher than the bite of the pair of squeeze rolls *c*, what will show us that the wool enters the squeeze rolls in an open condition, full of scouring liquor or rinse water, hence the machine will deliver the wool in an open state.

Between the end of the bowl and the bite of the squeeze roll, the web of wool passes over a perforated brass table (*e*) and through which perforations the liquor, as squeezed out of the wool by the rolls, runs off, and when it is collected in tank *f* (made of copper) under rolls and returned by gravity through the perforated section *f'* of tank *f* to the first compartment *A* of the settling bowl, which settles and collects all of the sediment. It then passes over a partition *g* to the second compartment *B*, where the grease and scum are retained and flow off through an overflow pipe *h*. It then, being free from sediment and grease, passes under the partition *i* to the third compartment *C*, to be in turn again discharged (*a*) into the main bowl by the action of pump *b*.

The operation thus explained, is continuous, working with an exceedingly large body of liquor and constantly removing sediment and grease; comparatively clean liquor only being pumped to the main bowl, what permits the machine to be in operation practically the whole day. By the use of this constantly going on cleaning process of the liquor, a much finer product as compared to that obtained by other systems of scouring machinery is the result.

Three bowls as a rule are used in the train of machines, although smaller mills may content themselves with two, whereas again larger mills employ four, all bowls used being connected by steam injectors. If then the scouring liquor in the first bowl gets worthless for future use, valves *v*, *v'* and *v''* are opened and the liquor runs to waste, *i. e.*, into drain *j*. The injector, in connection with a four bowl train, then draws the liquor from number 2 bowl into number 1 bowl; the liquor from number 3 bowl into number 2 bowl, and finally the liquor from bowl number 4 into bowl number 3, rinse water in turn being entered into bowl number 4, and which during the scouring process changes itself into a very mild scouring liquor. As will be readily understood the liquor drawn into the first and second bowl must in turn be brought up to its respective standard strength for starting the work.

Philadelphia has 314,000 homes; 55,000 separate business organizations; 16,000 manufacturing plants, covering a range of 300 separate lines of manufacture, employing a quarter of a million of skilled laborers.

ARTIFICIAL WOOLS.

(Continued from page 116.)

Dry carbonizing does not affect the colors of the rags as much as the wet process, and they may be brought back to their original colors by washing them in a strengthened soap-solution.

For this purpose, fill a barrel nearly full of water; add 10 pounds of soap, and boil until the soap is dissolved; then add 20 to 25 pounds of GRAN-CARB-SODA, dissolve completely, when it is ready for use, using about 3 pails of this liquor to the water in the washer.

For this process, the dry carbonized rags are taken to a duster, dusted thoroughly, and then washed in the liquor previously referred to, after which they are hydro-extracted and dried. Duster, Hydro-extractor and Washer should be located in close proximity to each other, allowing however, sufficient room for the operator to be able to work comfortably. To carbonize 1000 pounds of woolen rags by the dry process requires about 70 pounds of muriatic acid (22%).

The rags thus carbonized, either by the wet or the dry process, are now ready for picking, *i. e.*, transforming into Shoddy or Mungo, as the case may be.

In connection with Shoddy or Mungo where the presence of vegetable fibre (cotton) is no detriment, carbonizing is omitted, the result from such rags being known as *Extract*.

The rags (whether carbonized or not) are now ready for the rag or shoddy picker.

Previously to this procedure, it is very important to have the rags properly dusted in a rag duster, since if not properly cleaned, they will fill the room with dust, when picking; wear out the teeth faster; injure the appearance of the shoddy, and clog up the card wire in carding. Also, in oiling the rags previously to picking, such as have been properly dusted will require less oil.

CONDITIONING RAGS FOR PICKING: After a thorough dusting, of the rags on a Smith and Furbush Rag Duster, known as their Square Box Willow, and as shown in its perspective view in Fig. 5, the batches of rags are laid on the floor besides the picker, or in the bins provided for the purpose, putting in a layer of each grade used, and sprinkling with a solution of equal parts of wool or lard oil and water. The thus prepared lot of rags must be left standing for about ten hours previously to pulling them, so as to allow the rags to absorb as much of the moisture as possible, as they then will work better in the picking and later on in the carding process.

The rags are now ready for the *Rag* or *Shoddy Picker*. A favorite make of such a Picker is the one built by the *Smith & Furbush Machine Co.*, of Philadelphia, and of which a perspective view is given in Fig. 6. This Picker discharges the pulled product under its feed-table, a room being built at the back to hold the stock, and is connected with the picker by a trunk, through which the picker blows the stock into said room.

The cylinder of the picker is its most important

part, the same is strongly built and runs in brass bottom steps. The dimensions of the cylinder are 31 inches diameter from points of teeth, 19 inches wide, with 17 inches face of teeth. The latter are made from steel, evenly hardened and tempered, and put in the wood in a most careful manner so that it is



FIG. 5.

very rare occurrence for one to come out, or lag to split. The picker is provided with a lumping attachment to throw out all lumps, bits, &c., from the shoddy.

Remember that when shoddy is injured in pulling, *i. e.*, picking, no amount of skilled carding can restore it.

When contemplating to install a rag picker, the first important thing to consider is the kind of teeth in the cylinder that will do best the work required.

The best speed for the cylinder is 850 revolutions per minute.

To pull soft woolen rags and suit different grades of stock, 10,000 No. 10 teeth is the best adapted.

For pulling hard woolen rags, better results are obtained with from 12,000 to 14,000 No. 11 teeth and running the feed more slowly.

To pull wool knit goods or other soft woolen rags, preparing them for garnett machine or metallic breast card, use from 3000 to 4000 No. 8 teeth in cylinder and run the feed faster. This will give a longer staple.

The numbers of the teeth indicate the size of steel the teeth are made from; the higher the number the finer the tooth. No. 11 is about the finest and No. 8 is the heaviest used.

The most suitable distance between feed rolls and cylinder, in an average considered, is $\frac{1}{8}$ of an inch, this being also the dimensions used by builders, but it will be found necessary to reset them for certain kinds

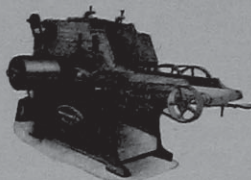

FIG. 6.

of stock. Remember, that the farther apart the feed rolls and cylinder are set, the longer the staple of the shoddy will be; also that by speeding the cylinder and reducing speed of feed rolls, a shorter staple will be the result, with less lumps, while a slower speed on cylinder and higher speed on feed rolls will produce more lumps. Be sure that the lumping device of the picker is set correctly, and when it will throw out all lumps over the back of the cover, and when these lumps then can be conveniently worked over, being placed on top of feed and used up as fast as made.

To regulate the space between feed rollers and

cylinder, do it by moving the cylinder, it being more convenient than to move the feed rollers and gearing. Loosen the pedestal bolts and move the cylinder as desired; but, before tightening the bolts again, see that the shaft runs free in the bearings and in line.

When at work, watch closely the result produced by different changes of speed in cylinder and feed rolls on the stock; it will guide you to obtain the best results.

One of the most important points in working a rag picker is to have a lap on the top steel roller and keep it in good working order. To attempt to pull rags with both rollers bare, would result in cutting them so short as to spoil the staple; but, by having a lap on roller, the rags will adhere to the same and be brought in contact with the rapidly revolving cylinder until they are reduced to shoddy. For this lap take a thin piece of rag of the same quality of stock as those to be pulled and after moistening, wrap it closely several times around the fluted part of the

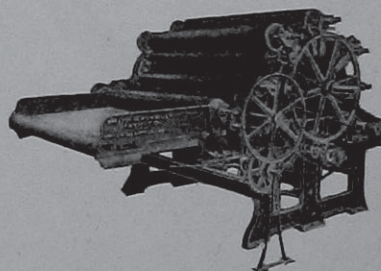

FIG. 7.

top roller. When in operation, the rags to be pulled, will roll around this and pull apart in itself with less friction than if pulled against the bare roller. When this lap, by working, becomes hard or badly worn, replace it with a new lap. Always leave the bottom roller bare.

To separate lumps from the shoddy, as previously alluded to, there is placed in the cover of the picker at its back a knife to operate on the lumps, raising them from the teeth of the cylinder, and, in the cover over the feed rolls is placed a fan to knock lumps, raised by the knife, back onto the feed apron again. Be careful that in setting the knife and fan, that they will only act on the lumps, throwing out as little shoddy as possible with them. Above the knife is the lumping or bit iron, a sheet-iron blade six inches wide, one edge working on hinges, the other edge having rods riveted into it. These pass through the top of the cover with thumb screws on the projecting ends of same, by which the lumping can be set to or from the cylinder as the case may require, said distance depending on the speed of cylinder and quality of rags to be pulled, the operator keeping in mind that the object of this attachment is to throw out, over the back door of cover, all lumps that escape the knife and fan, and to throw out as little shoddy as possible. Over the top of this back cover door of the picker is arranged a wood roller, for the purpose of carrying over the top edge of door any strings or bits that may gather on it, preventing them from going round with the cylinder.

To keep the teeth of a rag picker sharp and in good working condition, turn the cylinder around often. It should be turned daily where any quantity of shoddy is pulled, or say, after about every 1000 pounds shoddy pulled. The teeth, when new, are rough on the points and will not do good work until worn in better shape, which will require several turnings of the cylinder in the picker, before this is accomplished. After getting them in good working order, it will be noticed, after working the cylinder one



SHODDY, MAGNIFIED.

way some time, that the teeth will begin to wear dull on the working side and turn the edges and points of teeth in such a manner as to leave them in right shape to do good work on the other side, and when it then will be time to turn the cylinder again. Grinding the teeth injures their points, instead of sharpening them. The teeth must be in pulling and not cutting condition. When worn off some, the teeth are in the best condition for work; but, as they must necessarily be tapered for strength, when worn down considerably they become thick, requiring the cylinder



MUNGO, MAGNIFIED.

to be reversed more often. When the teeth becomes so thick as to injure the fibre, the cylinder requires new clothing and teeth.

The cylinder teeth will wear more in the middle than on the sides. To keep the face of the teeth level it will be necessary to grind the side teeth to keep them down with the other; but, as grinding the teeth makes them blunt on the ends, it is best to grind them as little as possible, only enough to keep them down, very little at one time and only as often as necessity requires. To grind them, take off the cover,

bolt or fasten in the most convenient manner a board on the back end of the picker frame, rest a piece of grindstone on this board and press it lightly against the side teeth with the cylinder in motion. Rest the flat part on a board, using the rough edge against the teeth, which will in time, wear hollow, forming the circle of the cylinder and become more effective. Where it is impossible to obtain grindstone, brown stone or any other gritty stone may be used. When the teeth in the cylinder are worn down in the centre it prevents accurate setting of the rollers and keeps a heavy lap in the middle, while they are clear on the ends, which, from the heavy pressure on the journals from the levers, will cause the rollers to break. The machine will also make more lumps when in this condition and produce uneven work.

Fig. 7 shows us the Smith & Furbush Rag Shredder, a machine which in its principle of construction is what we may term a coarse shoddy card, having for its object to either card out soft rags, or to better condition previously pulled hard rags for carding purposes.

(To be continued.)

FULL AUTOMATIC SEAMLESS KNITTING MACHINERY.

(Continued from page 119.)

Making the stitch by the cylinder cam requires careful study, so that a development of the cam outline, as given in Fig. 2, will be used to more clearly explain the operation. In order to have only a certain number of needles working for making the heel, it is necessary to raise the others out of the cam groove. These needles which are to remain out of action by being raised, are made with longer butts or shanks than the other needles, the two kinds being known as long and short butt needles respectively. In order to raise them, the jack cam *A* is brought into action, *i. e.*, pushed into the inner circumference of the cylinder cam, so that as it revolves, the long butt needles are pushed up, said needles being held in this raised position by means of a spring placed around the needle cylinder, the short butt needles remaining untouched. The cam cylinder in making the backward and forward movements, only operates these short butt needles which are down in working position. For example, the cylinder is revolving in the direction of the arrow, then a needle, after being passed by the point 1 of the needle rest, is moved upwardly by the switch cam *B* to the point 2, at which point it comes on the small projection of the upper pick *C* and is raised by it as the cylinder continues to revolve. The projection on the pick *C* is just large enough to hold one needle. At the point 3, the upper pick comes to the top cam *D* and the needle is placed in its highest position by said cam, thus raising one needle out of action. After the upper pick *C* has been moved up, the other needles are acted upon by the stitch cam *E* and the latches of the needles opened by the point 4. The upper pick *C* returns to its original position when the needle is off

of the projection. When the middle of the top cam *D* is acting on the needle, yarn is being deposited by the yarn carrier. This cam starts the needle down and enables the under side of stitch cam *F* to complete this movement, the stitch being cast off the needle, at the point 5. The end cam *G* then raises the needle up to its resting position at point 6, the switch cam *H* being easily raised from the under side by the needle, so that it does not interfere with the needles. The point 6 passes all of the working needles and then returns on the backward motion of the cylinder. As the cam goes back in the opposite direction from the first movement, a needle moves up on the switch cam

taking one away. This is necessary, because the upper picks still continue to operate and take one needle up each time.

The lower picks *K* and *L* must be released before they can operate on the needles. In the free position, they are situated above the shanks of the inoperative needles, that is, the projections from said picks. When the cam cylinder is moving in the direction of the arrow, the lower pick *K* comes with its projection over the top of two needle shanks (the size of the projection only allowing two), and as the cylinder continues to revolve, the needles are forced down by the pick into working position. On being released by the

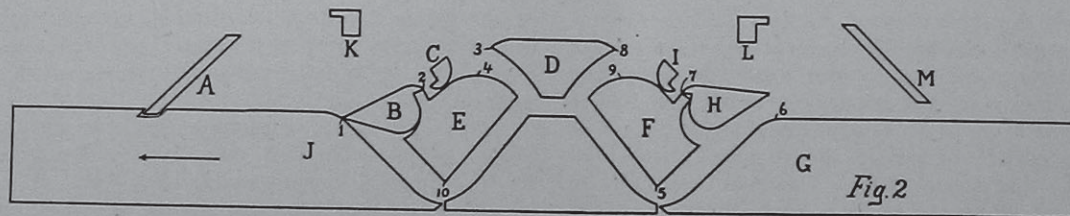

H to the point 7, at which point it comes on a projection of the upper pick *I*, which is raised as the cam cylinder continues its revolution. At the point 8, the needle is placed in its highest position by the top cam *D*, thus releasing the upper pick *I* which descends and rests on top of the shanks of the other needles in the same manner as the upper pick *C* on the opposite side. In this way a needle from the other side is placed out of action.

needles, the pick *K* assumes its original position after resting under the shanks until they are passed. As the cylinder returns on its backward movement, the upper pick *I* takes one of the returned needles back again out of working position, thus leaving the one needle.

The other working needles are acted upon by the stitch cam *F*, which carries them to their highest positions 9 with the latches open and the stitches resting on the needles below the latches. At the middle of the top cam *D*, yarn is deposited and as the needles are forced down by the under side of the stitch cam *E*, they catch the yarn in the hooks for a new stitch.

On this same backward movement, the lower pick *L* brings down two needles, one of which is placed back again out of working position by the upper pick *C* on the next forward movement of the cylinder. These operations continue until the heel is completed, when the clutch is thrown in with the continuously revolving piece and the cylinder consequently given a continuous revolution. At the same time, the lower picks are caught and held until the proper time, during the making of the toe. All of the needles which were out of operation are brought down by the under side of the pull down cam *M*, which is thrown into the path of the butts of the needles, and the same plain stitch is made as at first.

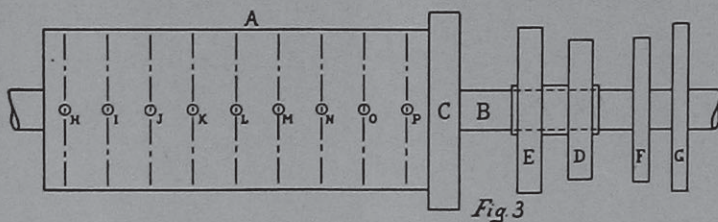

At the point 10, the stitch is cast off, and the end cam *J* then raises the needle to the resting point 1. In this manner, the stitches are made for the heel, raising a needle at each end, one at a time, for every movement of the cam cylinder. When sufficient needles have been raised out of action for the first portion of the heel, these needles which were placed out of action are brought down again, one at a time, at each end and at each movement of the cam cylinder. This is accomplished by means of the lower picks *K* and *L* in connection with the same pieces as used for placing them out of action.

While making the heel, an extra yarn or splice is run with the regular yarn in order to make that portion of the half hose or stocking stronger and heavier. To allow for this extra yarn, the stitch must be made longer, and to accomplish this, the needle cylinder is raised slightly. This causes the sinkers and needles to be raised, and as the needles go down to the same position as at first, the yarn as laid on the sinkers is drawn down the extra length that the sinkers were raised.

It was mentioned that one needle was replaced into working position at one time, which is true, but it is gotten by replacing two needles at one time and then

After making the plain part of the foot, the toe is made in the same manner as the heel. On completing the toe, the machine automatically stops off and is ready to have a new cylinder replace the empty one.

The method of obtaining these different movements for the several operations as explained, is shown by means of Fig. 3, which is a diagram of a pattern drum as used instead of the regular pattern wheel of the rib machines.

The drum *A* is a cylindrical piece, mounted on a shaft *B* and contains nine rows of holes, of these rows some containing more holes than others, extending around the drum, each row being in one plane perpendicular to the axis of the cylinder and equally spaced from each other. These rows are used to fasten the raisers for the pattern to the drum by means of screws. These raisers are of different shape for the different rows, according to the pattern desired. The pattern drum is given rotation by means of a ratchet *C* on the drum which is operated by a pawl. A regular pattern chain on the sprocket *D* is used in connection with the pattern drum to give the desired lengths of fabric of the different stitches. This pattern chain sprocket *D* is revolved by the ratchet *E* as operated by a pawl. A raiser on the chain pushes a lever up, which causes another lever to come up under the pawl for operating the ratchet *C*, and raise it out of action. This causes the pattern drum *A* to remain stationary and allows the yarn carrier to put in the required number of courses of that special stitch. The chain continues to revolve and causes the raiser to move from under the lever mentioned, which movement causes the ratchet to be operated by the pawl and consequently rotate the pattern drum again.

Near the end of the shaft *B* are placed two cams *F* and *G* for shifting the clutch levers, the cam *F* operating a lever to move the clutch into contact with the reciprocating motion for the cam cylinder. The cam *G* operates a lever for moving the clutch into contact with the continuously rotating wheel.

Each of the nine rows of holes of the pattern drum *A* forms a pattern surface with the cams screwed to them, for operating certain mechanisms in the machine.

The pattern surface indicated by row *H* is used for making a longer stitch while making the heel and toe in order to allow for the splice. This is done by operating a lever which raises the needle cylinder, thus producing the longer stitch as was explained.

Row *I* is used only when making ladies' hose for the purpose of shaping the stocking. The needle cylinder is raised in order to make a loose stitch which is gradually tightened as the stocking is made, by lowering the needle cylinder.

Row *J* is used for splicing the heel and toe, the cam placed on it being partly plain surface and partly inclined. The plain surface puts the extra yarn into contact with the regular yarn in order to create friction sufficient to carry it forward. The inclined surface separates the extra yarn from the regular yarn, but does not detach it. This splicing motion is situated above the machine and consists of a trough in which the extra yarn is passed, the end of which trough is provided with a cutting arrangement for this yarn when sufficient has been run. The trough is raised and lowered so that the extra yarn comes in contact with the regular yarn at the proper time and is then withdrawn. Friction and tension devices are also provided for the yarn.

Row *K* is used to bring the lower picks into action, which is done by moving a projection into the path of a finger situated on the cam cylinder. This action acts

through a lever to release the picks so that they are free to work.

Row *L* is used to put the lower picks out of action by moving a projection into the path of the finger so that it is raised by striking against it.

Row *M* is used in connection with making the splice by releasing the take-up spring of the feeding mechanism through suitable connections. This allows the yarn to be fed.

Row *N* is used to stop the machine when the half hose is completed, its use being unnecessary when making ladies' hose as the needle cylinder does not have to be changed.

Row *O* is used to give a kick off to the drum, that is, the drum is moved an extra distance in order to be in the proper position to give a required movement to the levers which will bring the take-up spring down more quickly.

Row *P* is used to operate the bob pin through proper levers. The bob pin operates the jack cams for raising and lowering the back half of needles when making the heel and toe of the half hose or stocking.

The Brinton Necktie Machine.

The H. Brinton Co., Philadelphia's most prominent Builders of Knitting Machinery are running their plant to its fullest capacity, in order to be able

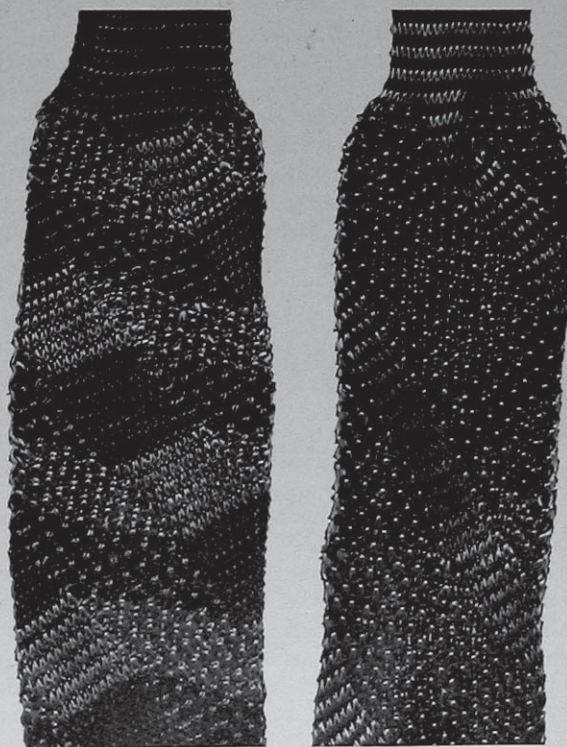

to supply the ever increasing demand for their Ribbers, Full Automatic Seamless Knitting Machinery, as well as their Necktie Machines; the demand for the latter of which is constantly growing since Knit Neckties became the "fad" of the season, the Brinton

Machine being the only successful machine of this type of knitting machinery in the market.

One of the most novel effects shown by the concern are plain knit ties in which the design is produced by means of *gauffré* effects, and for which there is at present a great demand.

Our illustration shows two designs of Neckties produced by means of a fancy weave in knitting on the Brinton Machine.

GREAT IMPROVEMENTS IN STOCK DRYING MACHINES.

The stock drying machines commonly in use heretofore were crude affairs compared to the machines that are now being built. The old machines were constructed of wood, they had the fan bearings inside in the heat, the stock was carried through on an endless wire screen which revolved about wood or sheet

passing around the sprocket wheels. This new conveyor will wear for a long number of years and during its operation is absolutely no trouble whatever. It operates more on the principle of coal handling machinery.

The Philadelphia Textile Machinery Company has put out a catalogue containing about Thirty cuts of this new machine. Many people are replacing the old type wooden machine with this new steel dryer.

PRACTICAL POINTS ON THE SHEAR.

(Continued from page 125.)

For grinding, a strop, bow, or fiddle, as it is sometimes called is used, the same consisting of a piece of leather belting about four inches wide and about sixteen inches in length, attached to a wooden handle,

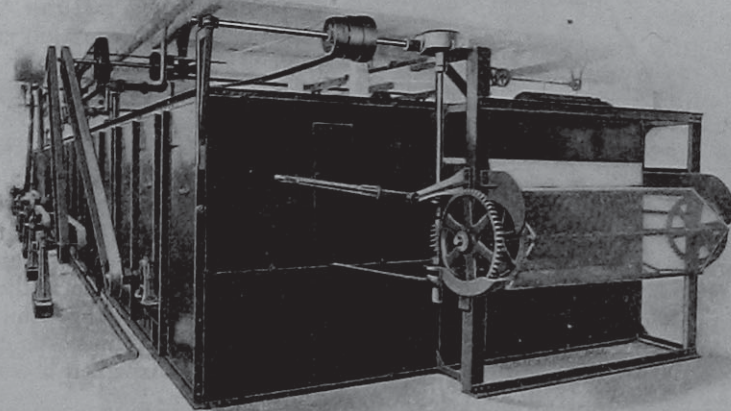

PROCTOR STEEL DRYER, VIEW OF DELIVERY END.

iron drums at either end, and the apron or conveyor was a continual source of annoyance, trouble and expense. The drying machines that are now being turned out by the Philadelphia Textile Machinery Company are constructed entirely of metal, the framework is made up of structural steel put together in accordance with the most approved engineering practice and the panels are made up of two sheets of metal with asbestos air cell between. The fan shafts are so arranged that all the bearings are outside the enclosure away from the heat where they may be reached at any time by the operators without shutting down the machines. In place of the old apron which was such a source of trouble this machine has in it what is called the "Interlocking" Chain Conveyor which needs no adjustment. This conveyor is guaranteed to run straight and true and requires absolutely no adjustment when once it is placed in the machine. It consists of a pair of endless chains connected together by cross rods, the carrying portion being made up of separate interlocking sections of galvanized iron wire cloth so constructed that the sections do not bend in

the leather being stretched over two cleats, as fastened at the proper distance apart, to said wooden handle.

A good mixture for grinding may be made of equal parts of No. 120 and flour of emery, mixed with a good lard oil to a thick paste, and when the grinding is nearly completed, finish up with a mixture of flour of emery and oil or at the finish with oil only. Spread this first mentioned mixture on the strop, and with the revolver turning backward apply the mixture to the revolver.

Now, by turning screw *d* at one end of the fly blades, draw the ledger blade up until it barely touches the fly blades, a feature which can be easily determined by the sound, after which do the same at the opposite end of the blades, until both ends strike lightly and evenly. Next draw up the middle of the ledger blade in the same way by its screw *d*, of the centre set, and follow this up with the two intermediately situated (see *X*) screws *d*, not shown in illustration, in connection with the broad shear. As soon as the ledger blade touches at any point, and thereafter

all through the grinding operation, vibrate the revolver constantly by hand, the full distance the journals will permit.

It is a good policy to change the place of beginning to apply the fiddle each time a fresh supply of emery is applied, since wherever the fiddle is first applied, that part is sure to get the most grinding and in this way things can be kept nearly even.

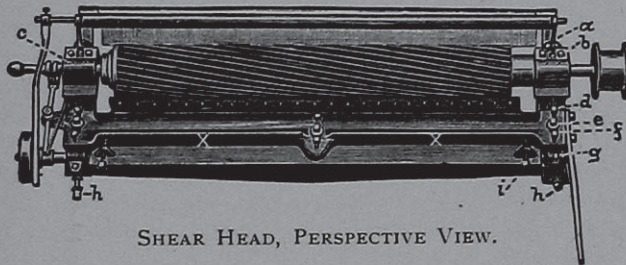

SHEAR HEAD, PERSPECTIVE VIEW.

Owing to setting the revolver back, grinding starts at the heel of the bevel on the ledger blade, forming a new bevel; keep on grinding until a slight turn of the edge shows that the grinding has reached the proper point. Apply the emery mixture freely, and as often as the sound of the grinding ceases, draw the ledger blade up and continue in this way until the bevel is finished, what will be seen by the appearance of the turned edge, and can be tested by wet tissue paper, in order to see if the fly blades will cut all the way across. If the edge be turned at any one point first, cease to draw up the ledger blade at this point until the edge turns all the way across. Wipe off the emery mixture from the front of the ledger, and examine the top of the rest, and when you will clearly see if the ledger blade is ground evenly. If the same is higher at any one place, draw up the ledger blade at that point only, until it is even, after which draw blade all across the width of the shear alike.

After bevel is complete, and the blades run lightly, finish grinding by running five or ten minutes with clear oil in place of the mixture. At no time during the process hurry grinding, and be sure that the fly blades run evenly, lightly and noiselessly, before stopping the use of the emery mixture. As soon as the fly blades cut evenly all the way across, take out the revolver, clean it from emery and oil, and do this also with the ledger blade. Now use a hone and rub lightly on ledger blade at a 20 degree angle, to remove feather edge made by the grinding, and finally finish honing by running the hone straight across from end to end. Wipe ledger blade after honing, and replace the revolver, bringing it about $\frac{1}{2}$ of an inch forward, so as to take a little away from the heel of your bevel. Put on the bevel and run the revolver backwards for about ten minutes, so as to polish the blades and insure smooth running, using for this purpose, oil and crocus. Take out the revolver and wipe all clean, using for this purpose saw dust and a whisk broom; also hone ledger blade slightly. Next clean boxes and journals, and put a few drops of oil in the former, and then replace the revolver in the shear head, screwing down the caps only moderately tight, and turn the revolver

the cut way first, in order to remove any feather edge that may have been produced in the honing process. Put on swab and then you are ready for shearing.

When starting shearing with a newly ground shear, be sure that the swab is well oiled, and at the same time, lower the revolver only a little at a time, until after a few pieces of cloth have been handled, in order to allow the blades to get smoothed up previously to lowering the revolver in the customary way.

After the blades have become smooth, it may become necessary to set them somewhat closer, by drawing up the ledger blade, a feature which can be resorted to, any time when the fly blades refuse to cut, that is provided they do not run hard. This grinding of the blades, on the shear, will do for a long time; however, in time both the fly blades as well as the ledger blade will need a general thorough overhauling, *i. e.*, regrinding on a special grinding machine. Some mills will have such a grinding machine, whereas others are without it, and when then blades have to be sent to the machine shop for this purpose.

A shear grinding machine, in which the ledger and cylinder blades are ground at the same time, will be found a valuable adjunct to any mill, since it is unhandy, when obliged, to send the blades to a machine shop to be ground. To accomplish this, many machines have been designed. Some were made with a long roller grinder, run in oil or water, but which would only either grind the fly blades or the ledger blade and not both at the same time. Messrs. B. S. Roy & Son, build a grinder designed to grind both fly blades and ledger blade at the same time, without oil or water. Fig. 7 shows this grinder in its perspective view. The same consists of a suitable iron frame, in which is situated a traverse grinder, fitted

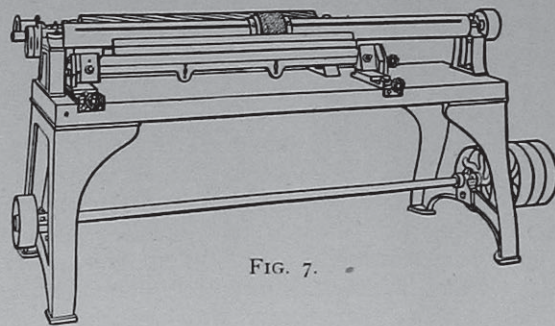

FIG. 7.

with a solid emery wheel, with about 4" face, and a differential motion for traversing the wheel very slowly while revolving. On each side of the grinder is a set of bearings, one set for the fly blades (shown in rear of illustration) and one for the ledger blade (shown in front of illustration). These bearings are adjustable to the grinder, the ones for the ledger blade being made to be adjusted to any angle, while the blade is being ground. By using a traverse grinder, the grinding wheel runs dry, oil or water being unnecessary as is required when a roller grinder is used. Different widths of blades can be ground on the same machine. With this machine, accurate and rapid grinding can be made, thus resulting in a saving wherever used.

However, after shear blades have been run for years and years and have been ground innumerable times, there will come a time when they will get so that even grinding will fail to make them cut properly, they will heat frequently and get rough, and it is next to impossible to do any good work with them, and when new ones have to be substituted by the machine builders.

DECATIZING WOOLENS.

By B. Kozlik.

(Continued from page 86.)

The various results of decatizing, according to the amount of decatizing done, are graded into luster, half-luster and dull-luster decatizing. The result of this finishing process depends upon different items, for instance the quality and the count of the yarn used in the construction of the fabric, the weave used in interlacing warp and filling, the other finishing processes the fabric has been subjected to, the intensity of the pressing given to the fabric, and finally depending considerably upon the execution of the decatizing process, and make of machinery used, the Schuchardt & Schütte machine as illustrated on page 85 being acknowledged, a most satisfactory make.

The finer and more lustrous the raw material used, the longer the fibres of the nap and the more parallel they are resting at the same time, the easier a good result with reference to decatizing is obtained.

Heavily pressed fabrics are more suitable for decatizing than such as have received only slight pressing. Considering steam decatizing and water decatizing, a lighter luster may be obtained by the first mentioned process.

To obtain a nice lustrous decatizing result, the finisher has to take this matter carefully into consideration already at the gigging, and when he must aim after luster to the fabric by means of excessive wet gigging. In the same way, such fabric should receive hydraulic pressing.

Reflecting, in connection with roller decatizing upon the greatest possible luster, the cloth must be wound under great tension upon the decatizing roller for a considerable time subjected to the influence of steam, leaving the fabric itself cool down while in this rolled up condition. If desiring only a slight luster, unwind the fabric from the roller at once as soon as the decatizing process is finished.

You can never obtain the same successful lustrous finish in connection with fabrics presenting a bare face that you can in connection with such as have a nap finish, since in connection with the thread bare face, the long fibres of the nap are missing on the face of the fabric. Fabrics interlaced with warp effect weaves, *i. e.*, in which the warp threads float to a considerable extent, like 3 and 4-harness twills, warp effect; the 4-harness broken twill, warp effect; the 5-leaf satin, warp effect, etc., will more readily permit a high lustrous finish.

In connection with a half-lustrous finish, and which is a medium between luster and dull-decatizing, the items previously referred to in connection with lustrous decatizing must be modified in their appli-

cation, whereas in connection with dull-decatizing, only a weak decatizing of short duration must be practised, unwinding the fabric at once from the decatizing roller as soon as the process is finished; don't let the fabric get cool while wound on its roller.

By means of decatizing, the fabric gains with reference to its general appearance, but it gains nothing with reference to its strength and elasticity, in fact, if the process is entrusted to a careless workman, he may, by means of excessive steaming, make the cloth tender.

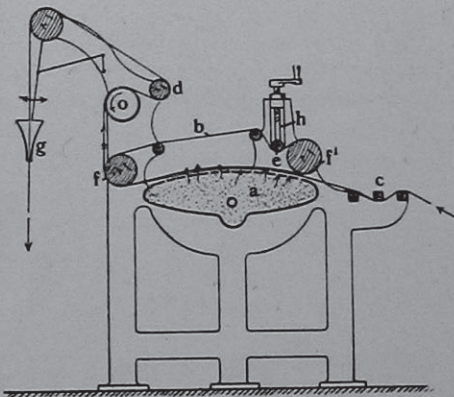

FIG. 4

Decatizing also influences the shade of the color of the fabric, a strong decatized fabric will present a darker shade than a fabric from the same range of goods dyed at the same time but less strongly decatized.

Conditioning the Fabric for the Market.

SECOND DECATIZING, TAKING OFF THE LUSTER

The next process the fabric is subjected to after Decatizing has for its object the removing of any surplus luster, the fabric by this process receiving the required final market finish. By the wool fibres again trying to resume as much as possible their original position in the fabric, out of which they were pushed during the various finishing processes, as tentering, stretching, etc., the fabric will shrink by being subjected to what is known as the *shrinking process* (also called *sponging*). If a fabric thus handled is then subjected to tailor's goose, its texture will not change, neither will the same when made up in the garment.

To produce this finish, a Second Decatizing or Taking off Luster is an absolute necessity. Napped goods require besides, a run through a Brushing Machine.

Processes and Machinery now referred to, have for their object the bringing of the fabric into proper condition for the market.

For the Second Decatizing, Steaming, Shrinking or Sponging, as variously called, a steam table is used, over which the fabric to be treated is made to pass slowly, but without any more tension than absolutely necessary to properly smoothen out and guide the cloth in its travel.

Fig. 4 shows in its section the Shrinking or Sponging Machine as built by Schuchardt & Schütte of

New York. A description of the process is best given by quoting letters of references accompanying our illustration, and of which *a* is the perforated steaming table, over which the cloth in its travel through the machine passes. In order that the fabric passes over this steaming table properly smoothed out, as well as under a slight pressure (no tension) the same is made to enter the machine by passing between the three stretching rods *c*. *b* is an endless apron made of felt cloth, which exerts a slight pressure on to the fabric, while passing over the steaming table, in turn compelling the steam to thoroughly enter into and through the fabric treated, before passing through the apron. Apron *b*, as well as the cloth steamed, pass around drafting roller *f*, hence rotate at a uniform speed. After leaving roller *f*, the fabric comes in contact with lustering roller *o*, rotating in a reverse direction (see arrow) to that of the travel of the cloth,

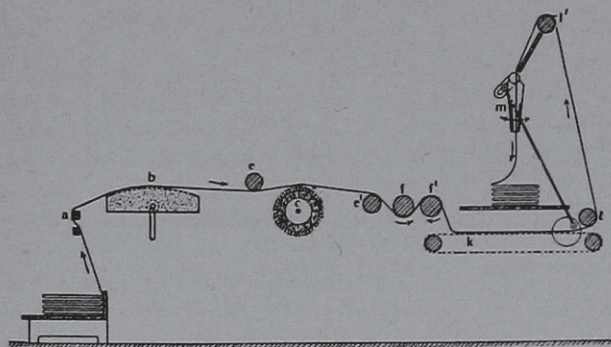

FIG. 5

said lustering roller being provided to impart to the fabric a smooth face. The fabric then passes around guide roller *d*, then to the folding device *g*, which folds the cloth in the usual manner on a table or truck.

The steaming table *a*, is a closed box, with holes in its arched bed, and which is covered with several layers of felt cloth.

h represents a tension device for exerting pressure, by means of roller *e*, to the endless apron *b*.

f' is the mate guide roller for the apron.

As simple as Steaming, *i. e.*, Second Decatizing may look to us, the process requires practical experience by the operator, since if carried on carelessly, the finish of the fabric may be spoiled. For example, if in its travel over the steaming table, the fabric does not pass in an entirely smooth, open way, *i. e.*, if creases are formed, no matter how small they are, the same are liable to impart to the fabric what is known as *luster stripes*, and which, more particularly in connection with light weight fabrics, are a detriment to a perfect finish. Be careful that the cloth does not pass over the steaming table under too much tension, since this is apt to stretch the fabric unduly in its length, with the consequent disadvantage of a tendency to shrink the fabric unnecessarily in its width. Such tension must be prevented under all circumstances.

Fig. 5 shows another steaming machine which is very extensively used, the builders of the same claim-

ing that by means of it, all chances for spoiling the finish of the fabric by the operator are omitted, besides preventing shrinking of the fabric in its width.

The fabric enters the machine by passing between stretch rods *a*, passing in turn over steaming table *b*, under guide roll *e* and over guide rolls *e'*. Between these two rolls, the fabric comes in contact with brush *c*, the amount of brushing imparted to the fabric depending on the setting (raising or lowering) of the guide rolls *e* and *e'*, a feature readily understood by the reader. From guide roll *e'*, the fabric in turn passes under drafting roll *f* and over drafting roll *f'*, after which it is delivered on to the endless traveling (lattice) apron *k*, passes over guide rolls *l* and *l'*, and from there into the folding device *m*.

The claim of the builders of this machine is that in permitting the fabric to travel in its loose open condition on the endless apron *k*, it is thoroughly cooled, without tension, hence no stretching of the fabric in its length takes place. Drafting rolls *f* and *f'*, are driven by a differential motion, whose surface speed is regulated by means of differential cones.

Rolls *f* and *f'* are placed side by side, in order to prevent the least pressure upon the warm cloth under operation. The surface speed imparted to these two drafting rolls *f* and *f'* regulates the length of time the fabric is under the influence of the steaming table, hence any amount of steaming can be given to the fabric by means of regulating the speed of these two drafting rolls. As previously mentioned, heavily giggered cloth, and in which the nap must rest in its proper direction, such fabrics after steaming are then run through a brushing machine, which, if so desired, may be connected direct to the steaming table.

Growth of the Silk Industry.

We imported in 1908 raw silk to the value of \$65,021,066, or about the same as in 1906, the imports in the intervening year 1907 having reached \$73,097,581. The largest share comes from Japan—about \$40,000,000 worth a year—while about \$15,000,000 worth is brought from Italy.

The latest census figures, those for 1905, showed that there were 624 silk mills in the United States, with \$109,556,621 capital employed, which was double that of 1890. In 1870 only \$6,231,130 was invested in silk mills, and in 1860 the amount was only \$2,926,980. The value of the products proportionately increased from \$6,607,771 in 1860 to \$133,288,072 in 1905. The raw silk used in 1860 was 462,965 pounds, and in 1905 it reached 11,572,783 pounds. The raw silk imported in 1908 amounted to 18,723,119 pounds, exclusive of waste.

The importation of manufactured silk goods, however, has continued to grow, having advanced from \$31,281,273 in the year 1905 to \$34,621,064 in 1906 and \$41,035,836 in 1907. There was a natural decline in 1908, owing to general business curtailment, the imports reaching only \$27,020,212. The share of France in this trade is about 40 per cent., Germany about 20 per cent., and Switzerland and Japan each about 10 per cent.

POINTS ON SILK LUSTERING AND DYEING.

Lustering is a most important process in a silk mill, the operation closely following that of dyeing, and has for its purpose to condition the silk for further mechanical treatment and at the same time give it the proper feel or handle. The latter includes, but does not consist solely in the *rustle*, although the latter characteristic point is of much importance, in many cases, later treatment depending considerably upon it.

The amount and character of handle to give to silk, depends entirely upon the use it is to be put to in wear, as well as the prevailing fashion; experience being a necessity for a satisfactory result.

The average buyer of a silk dress tests it by its rustle and weight, which clearly shows that silks heavily weighted offer far more attraction to the average public than such as are not, or if so, only little weighted.

In hot and very dry weather, for sake of quality as well as production, it is necessary in the spinning as well as the weave rooms of a silk mill to keep the air moist by means of one or the other of the many Humidifying Apparatuses now in the market. In such weather, silk must never be lusted with sulphuric acid, or dried excessively, for when over dried, such silk is almost incapable of taking up the moisture necessary for further treatment. In the loom, over dried silk is apt to become electrified, more particularly when used in ribbon looms, and where, in its travel from bobbin to the fell of the fabric, it rubs against either glass or varnished wooden rods. In either case, the silk clings to the rods and is broken by the increased tension thereby given to it.

Silk destined for the manufacture of velvet or plush, especially schappe silk, requires a special lustering method, so that the threads will cut properly. Velvet pile is produced by placing in the warp shed of each pile pick a fine, flat metal wire, having a small groove on its top, in which travels the knife of the trevette, thus severing the pile; or the wire is formed minus this groove but having one of its ends formed into a knife blade, which cuts its way through the loops when pulled out of the fabric.

Plush refers to a longer pile than velvet and most frequently is made on the loom known as double plush loom, *i. e.*, weaving two fabric structures at one time, one above the other, in such a way that the pile threads connect the two fabric structures. These pile threads, as travelling from one fabric structure to the other are then cut automatically in the loom, by means of a knife, travelling to and fro in the loom, in the centre of the pile. Unless the lustering has been satisfactorily done, the pile will not cut properly.

To produce a perfect lustre, the silk must be suitably dyed. It is frequently treated in single acid baths, and manufacturers of dyestuffs usually prepare the samples for their pattern cards in that way, however silk thus treated loses greatly in lustre and in handle.

Silk should be dyed in a bath containing fat and albumen, afforded to perfection by bast-soap, obtained in degumming the silk. This bast-soap is added to the dyebath, and with the addition of acid forms an

emulsion of fatty acid in which the silk is dyed. The silk then regains possession of the albumen it had lost in degumming, as well as taking up fatty acid. Silk thus dyed becomes fit for lustering, which then only consists of a simple scouring. Sulphuric acid gives silk a straw like handle, hence it is not to be recommended. Acetic acid is too volatile, the benefit to the handle it imparts to the silk, when used, disappearing in time. The best acids to use are citric and tartaric, the former in the shape of lemon juice. These acids are not volatile, and give a good and permanent handle; however silk treated with them must not be dried to excess, or it will take up its necessary moisture with difficulty. Phosphoric acid is an excellent substitute for the two organic acids referred to; is cheap, not too acid, non-volatile, and extremely hygroscopic; unlike sulphuric acid, it only enters loosely into combination with silk. These properties make phosphoric acid excellent for the purpose, favoring at the same time the subsequent treatment of the silk. The hygroscopic power of the acid obviates the necessity of having to be so careful not to over-dry the silk. Phosphoric acid gives quite as good a handle as any other agent used for the purpose.

If lustering black silk, without bast-soap, or weighted silk to which a good handle is difficult to impart, or if a special, delicate handle is required, oil and acid are used. The oil used, must be the very best of olive oil, absolutely free from an uncombined fatty acid. The proper quantity of it (from $\frac{1}{10}$ to 3%) is mixed with a little carbonate of soda and emulsified by a strong current of direct steam, this emulsion being stirred up energetically in the acid bath, and the silk passed through it about five times. This must be done quickly before the oil separates. If the emulsion separates during the treatment, oily stains will appear on the silk. The acid used is almost invariably citric, but, for the sake of economy, a little sulphuric acid is added first, in order to neutralise the carbonate of soda, and thus prevent any waste of citric acid, which is rather expensive. Citric acid, however can be quite well replaced by the far cheaper phosphoric acid.

Silk, especially black silk, may easily turn rancid under this treatment, due to the use of inferior olive oil, or the use of too much oil, or owing to the silk not being properly rinsed before the brightening process. If it happens, the silk is put through hot water in which china clay is suspended, the latter removing the excess of fat. This is the only method which does not affect the color of the silk.

Silk for velvet, more particularly schappe, must be dyed with plenty of bast-soap, giving it enough fatty acid, so that Turkey-red oil is not needed. Oxystearo-sulphuric acid, is of great assistance to the bast-soap, however not more than 3% of the weight of the silk must be added to them. Silk intended for velvet will not cut well in the loom if any mistake is made with bast-soap dyeing. Silk intended for such pile fabrics is prepared in a bath containing 3 to 7% (of the weight of the silk) of alum or the corresponding amount of sulphate of alumina. This bath is used at