

TEXTILES

A Monthly Technical Journal

VOL. 15. NO. 1.

Publication Office **BOSTON, MASS.** New York Office
79 Milk Street 42 West 39th Street

JULY, 1919

MARCUS FRIEDER, President

GENERAL SILK IMPORTING COMPANY

25 Madison Ave., New York

Yokohama Shanghai Shameen, Canton
Milan Lyons

RAW, THROWN, SPUN SILK

SMITH & FURBUSH MACHINE COMPANY

PHILADELPHIA, PENN.



Builders of Complete Outfits of Machinery for the Manufacture of Woolen Yarn, also Cotton Waste, Asbestos Yarns, etc., on the Woolen Principle; Shoddies, Cotton or Wool, with either Cards or Garnetts; Felts for the Mattress and Upholstery Trade; Wiping Waste; Rewoven Jute Gunny Bagging

Specialists on Machinery for using all sorts of Textile and Fibrous Wastes



*The Mechanical
Weather Man*

says:

Weather
may come and
weather may go,

But Carrier
makes weather
whether or no!

Carrier Engineering Corporation

Automatic, Guaranteed AIR CONDITIONING EQUIPMENT for Heating, Humidifying, Cooling, Ventilating the Textile Mill

39 Cortlandt Street, New York, N. Y.

BOSTON BUFFALO CHICAGO PHILADELPHIA

Cooley & Marvin Co.

BOSTON, MASSACHUSETTS

Tremont Building

CHICAGO, ILLINOIS

Conway Building

Accountants and Engineers

AUDITS—COST SYSTEMS—APPRAISALS
INDUSTRIAL MANAGEMENT

Manufacturers, when planning for increased output, greater efficiency and lower costs find that questions arise upon which thoroughly reliable information is needed. If your organization cannot supply the facts, promptly, you need our service.

If your costs are not accurate, if your expenses are too high, shipments delayed, goods imperfect, the factory congested at some points and idle at others, you need our service. Your inquiry is invited.

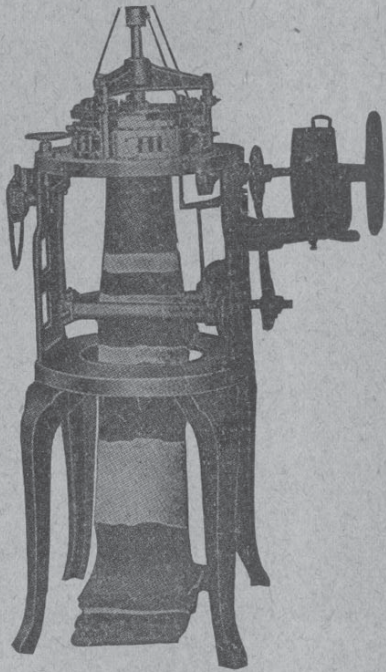

STAFFORD & HOLT
BATHING SUIT
MACHINE

The Stafford & Holt Jersey Sweater Machine

The latest and best machine for making fabrics made in the single stitch such as used in Bathing Suits and Jerseys.

Automatically stripes various colors in widths desired.

Recognized by the knitting trade as the most perfect machines for Jerseys and Bathing Suits.

Write for Catalogue

STAFFORD & HOLT
LITTLE FALLS, N. Y.



YOUR SHARE

OF
\$10,000,000

You are entitled to more
of this expenditure

"Do you realize that over \$10,000,000 worth of full fashioned stockings are made in America each year?

If you are today making a cheaper line of hosiery and possess the ambition and initiative to reach out for the highest quality in your line of product, let us show you what is required in the way of machinery.

Full fashioned hosiery is today an American product. Only a small percentage is still imported.

The same is true of the machinery for making full fashioned hosiery. It is an established domestic industry and we can show that it will pay you to buy our machines and get into the class of the manufacturers of the best American hosiery."

TEXTILE MACHINE WORKS

The Makers of
The Standard Machine for making
American-made Fashioned Hosiery
READING, PA.

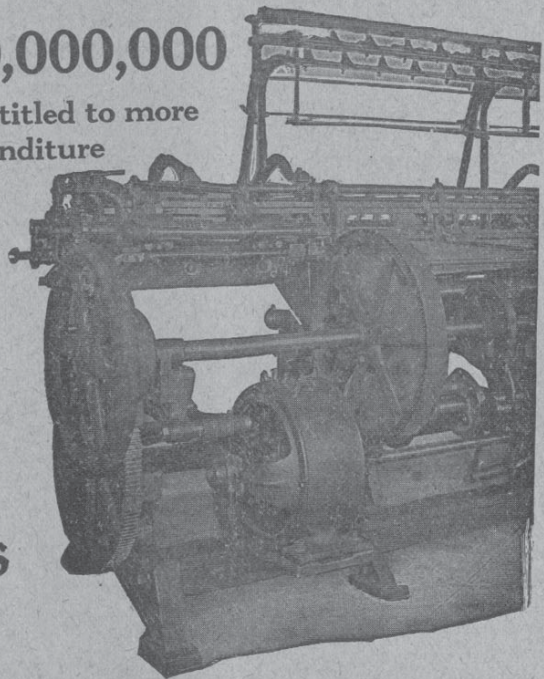

FOR WOOL AND SHODDY

Always
Uniform
and
Reliable
★
Once Used,
Always Used



Unequalled
Scouring Agents
and Fibre
Lubricators
★
Do Not Gum
Penetrating

SAMPLES GLADLY SENT ON REQUEST

WRITE US ABOUT YOUR NEEDS.

BRADFORD OIL COMPANY, INC.

Lynn, Mass.

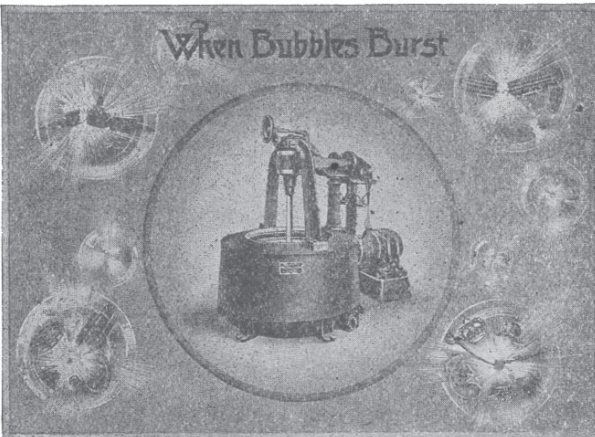

TOLHURST EXTRACTORS

are always found running smoothly, quietly, efficiently—without any fuss—doing their work uninterrupted, day in and day out, in war or in peace—boom or panic. They have run like this since 1852 and, each succeeding year, have run better.

There are few things in this world that one can tie to, but among them is the

TOLHURST EXTRACTOR

Built Right — Sold Right — Found Right

TOLHURST MACHINE WORKS
Established 1852 TROY, N. Y.
New York Office, 111 Broadway

Southern Rep.
FRED H. WHITE
Realty Bldg.
Charlotte, N. C.

Western Rep.
JOHN S. GAGE
Harford Bldg.
Chicago, Ill.

Canadian Rep.
W. J. WESTAWAY CO.
Sun Life Bldg.
Hamilton, Ont.

H. BRINTON COMPANY

Circular Knitting Machinery

RIBBERS KNITTERS BODY MACHINES

Each style the latest, with all
modern improvements. Simple
in construction, well built of
the best materials.

*Catalog and samples
mailed on request*

213-217 Race St., PHILADELPHIA, PA.

Machinery on the Ceiling Would Double Production

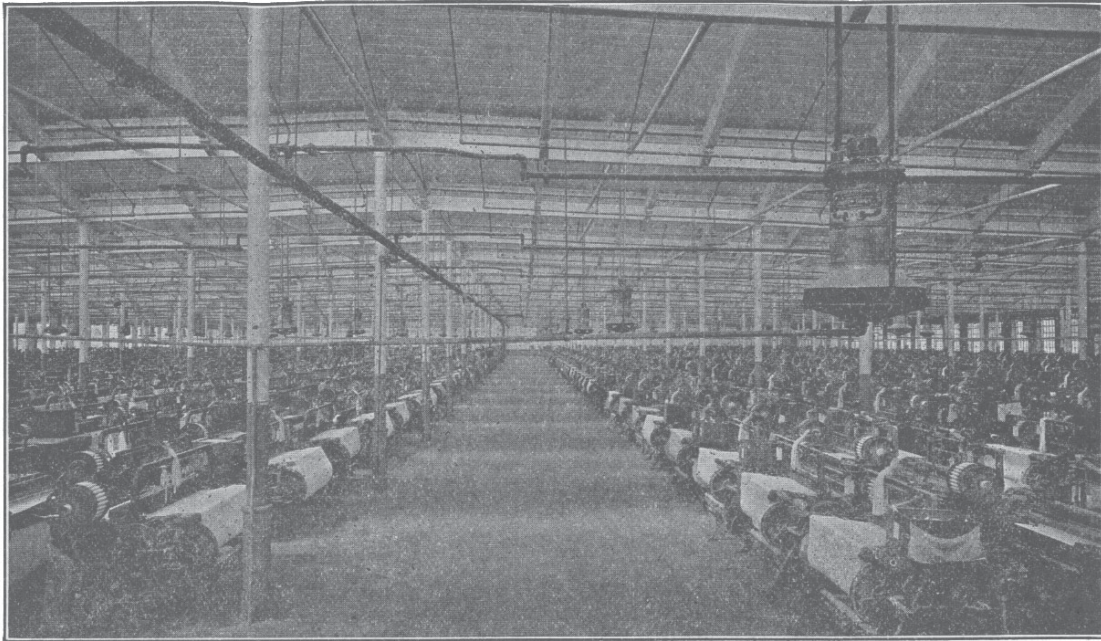

HUMIDIFIERS ARE EQUAL TO USING THE CEILING FOR PRODUCTION

YOU place your machinery on the floors of your mill, mostly in response to the application of the laws of gravity.

But if some one would design textile machinery to operate successfully on your ceiling—and you could get operatives that had the faculty of working and walking upside down—this additional equipment would have some effect on your production.

Wouldn't it?

And also on your profits?

Turbo and Cramer humidifying equipment—scientifically designed for your specific manufacturing problems are the equivalent of just this.

They are just as if you used the ceilings of your plant for additional machinery.

Only.

The operatives still stay on the floor.

Machinery on the ceiling would present quite a problem.

Humidifiers near the ceiling—out of the way—solve problems.

Don't think—just because you have a humidifying equipment—you have gotten all there is out of it. Installations of humidifiers—are engineering problems. We have made much and exhaustive study of the subject—have learned much during the past few years particularly.

If you have not had the benefit of our data as applied to your problem, there is something more in humidifiers for you. Even if you have humidifiers now.

One of our customers installed Cramer humidifiers—he was already equipped as he thought—and saved \$28,000.00 the first year. The humidifiers cost him less than that amount.

Our engineers can determine accurately.

Parks-Cramer Company

*Engineers & Contractors
Industrial Piping and Air Conditioning*

Fitchburg

Boston

Charlotte

TEXTILES

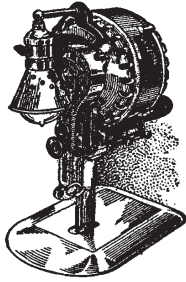

EVERY TIME-SAVING AND CON-
VENIENT DEVICE IS PROVIDED ON

UNIVERSAL CUTTERS

ASK FOR A TRIAL. NO OBLIGATIONS

UNIVERSAL CUTTER CO.

NEW YORK
245 Seventh Avenue
BOSTON

CHICAGO
506 S. 5th Avenue
BALTIMORE

PHILADELPHIA
605 Arch Street
MINNEAPOLIS

St. Louis, Mo.
CLEVELAND
1220 W. Sixth Street
SAN FRANCISCO

**Headquarters
for Technical Books**

TEXTILES is able
to supply any
book on textile sub-
jects, which is now in
print.

If interested in any
kind of textile books
listed or not listed in
our book catalog, write
us and we will be glad
to procure same for
you.

Address Book Department
TEXTILES
79 Milk St., Boston, Mass.

"The House of Taylor"

HOTEL MARTINIQUE

BROADWAY, 32d & 33d STS.
NEW YORK

One Block from Penna. Station.
Baggage Transferred Free.

Equally Convenient for
Amusements, Shopping
or Business.

Direct Entrance to
B'way Subway
and Hudson
Tubes.

600
ROOMS
400 BATHS

RATES

From \$2 Per Day

A SPECIALTY
155 PLEASANT ROOMS
With Private Bath

\$3 Per Day

The Martinique Restaurants Are Well Known
for Good Food and Reasonable Prices.



The Perfect PATENT KNIT-ALL Cone

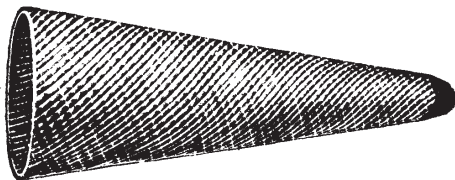

The smooth round polished point allows the yarn
to knit off without catching and breaking



SEE THE POINT

All Sizes All Colors
All Kinds of Paper Tubes

Made by

THE PAIRPOINT CORPORATION

Paper Mill and Tube Factory, New Bedford, Mass.

ANDREW G. PIERCE, Jr., Pres.

THOMAS A. TRIPP, Vice-Pres.

FREDERICK R. FISH, Gen. Mgr.

WILLIAM A. CLARK, Treas.

Does Your Office, Store, Factory,
Kitchen, Bathroom or Corridor
NEED A NEW FLOOR?

Before installing wood, linoleum, oilcloth, tile, marble or other material that will wear out and need renewing in a short time

Get Our Price on a Floor That is Everlasting

We install any size job in a single day without disturbing existing conditions.

IT IS ALSO DUST, DAMP, VERMIN AND FIRE PROOF

Hundreds of high class testimonials from homes, business houses, hospitals, factories, etc. Phone or write for prices and particulars.

Bell 'Phone—Belmont 182

Write for folder C.

Keystone 'Phone—West 649

PHILA. MINERAL FLOORING CO.

5632 SUMMER STREET

PHILADELPHIA, PA.

COREY
LATCH NEEDLES

Are made in a model factory by employes of long experience, under the best factory conditions. The COREY is the needle par excellence—it is positively superior. Our factory is the largest individually owned needle factory in America.

FOR QUALITY

Specify COREY needles. Best workmanship, perfect design, great strength and durability, high grade steel, and permanent smoothness characterize the COREY latch needle. Our line is unrivalled—COREY and quality are synonymous when applied to needles.

Send for Prices and Samples

William Corey Company

Chauncey H. Williams, Sole Owner

MANCHESTER, N. H.

W. D. HUSE & SONS

LACONIA, N. H.

The HUSE Improved Winder

Occupies only about half the floor space and runs with half the power required for ordinary winders.

Spindles friction driven—no bands. No vibration. Adapted for winding small sized bobbins by simply changing the cams, or two sizes of bobbins can be run at same time.

Variable speed attachment furnished for skein winding. Extremely simple, durable, smooth-running and has very few parts.

Furnished with any number of spindles desired.

These are but a few of the many points of supremacy.

Write for our catalogue giving full information.

The HUSE Ribber

This machine is made in any size desired from $2\frac{1}{4}$ to 6 inches in diameter, and with attachments for making welts, loose courses, tuck stitches and stripes, double knee and high spliced heel.

Can also be used without extra attachments for producing straight ribbed work.

Adapted for making rib tops for half hose, rib legs for ladies', misses' and children's stockings, also for shirt cuffs, drawer bottoms, etc.

Built with either one or two feeds, as best adapted for work required.

Simple, very few parts, and well built throughout.

Send for our new catalogue.

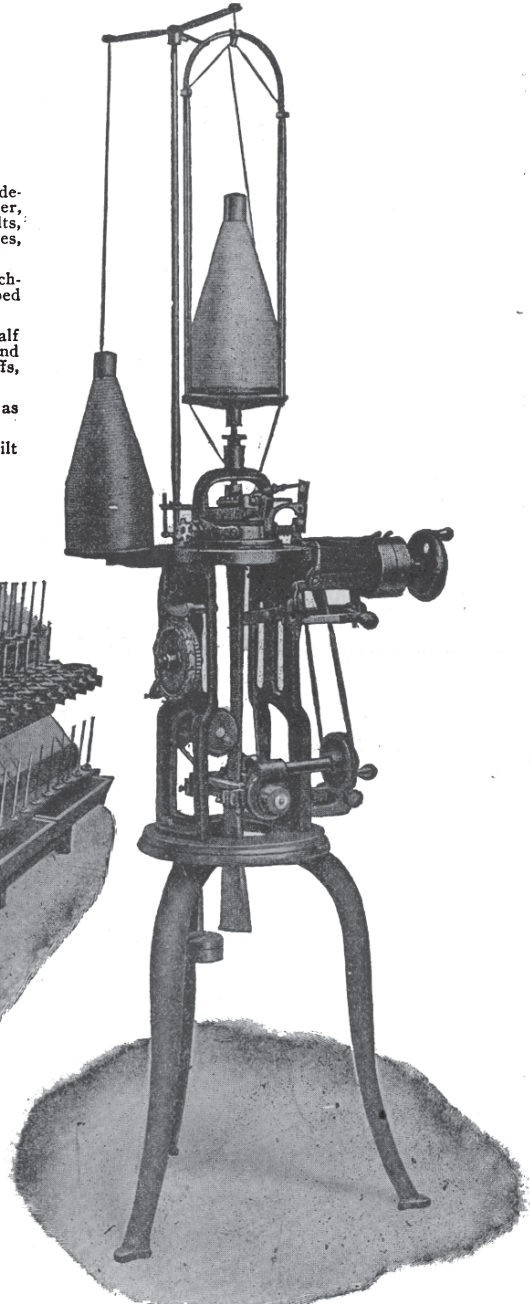
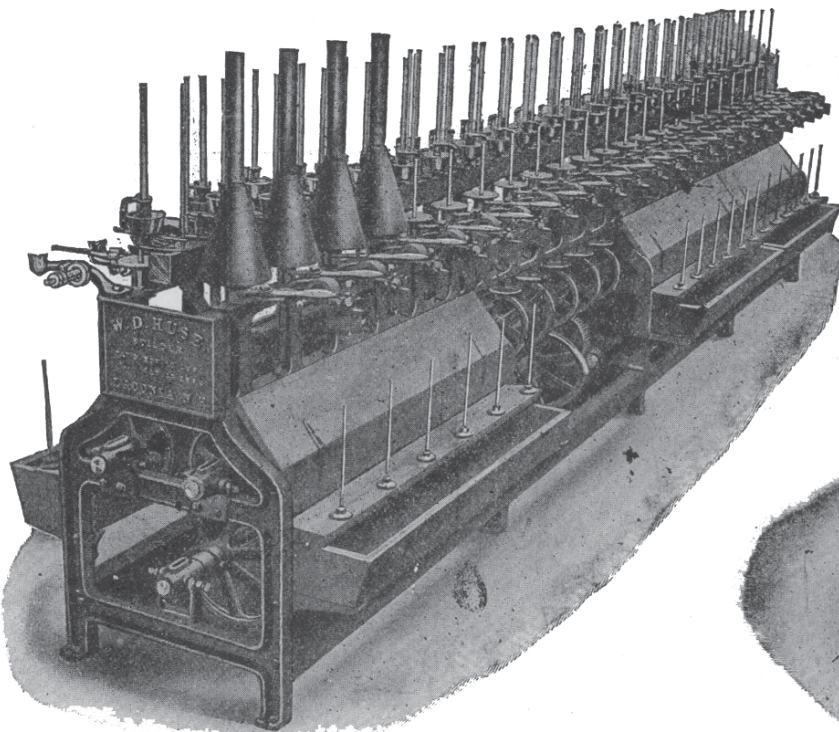

LACONIA NEEDLE COMPANY, LACONIA N. H.

Manufacturers of
HIGH GRADE LATCH NEEDLES

Thoroughly finished, durable and, we believe, the most satisfactory and economical needles that can be produced. Made by skilled needle makers, from the highest grade wire and on new, improved and accurate machinery.

These needles are carefully inspected before leaving our factory and no effort is spared to keep our output up to the very highest standard. We are confident you would be pleased with these needles. May we send you samples?

TEXTILES

A MONTHLY TECHNICAL JOURNAL OF THE
TEXTILE TRADE

Published by

THE TEXTILES COMPANY

Post Office Square Building : : 79 Milk Street, Boston, Mass.

Telephone Main 19

EDWIN B. PILLSBURY, Business Manager

SAMUEL S. DALE, Editor

Cable Address, "Textiles, Boston"

New York Office: 42 West 39th Street. Telephone Greeley 4295

J. CARLISLE LORD, Manager

SUBSCRIPTION

In the United States	\$1.00 per Year
To Canada and Foreign Countries	\$1.50 per Year
Single Copies	15 Cents

REMIT TO "TEXTILES" BY EXPRESS OR POSTAL MONEY ORDER, CHECK OR BY ENCLOSING CURRENCY WITH ORDER AT OUR RISK. ADVERTISING RATES SENT ON APPLICATION

Entered as second-class matter January 14, 1916, at the post office at Boston, Massachusetts, under the Act of March 3, 1879, (Copyright, 1919, by Samuel S. Dale.)

ALLEN BLEACHING KIERS

ALLEN KIERS are either of the Allen Patent Injector Type or "Allen Worcester" Kiers, equipped with Motor driven pump and especially constructed Heater.

The "Allen Worcester" Kier, which is wonderfully popular, is mechanically correct and can be depended upon to do exceptionally good work. The motor driven pump gives positive and even circulation and the strength of the liquor is maintained throughout the Boil. Tendered goods are impossible.

Let us show you these Kiers in operation.

Allen Heating Boilers, Horizontal, Tubular, Upright and Locomotive Type, have been on the market for many years. We also manufacture the Allen Improved Logwood Extractor.

WORCESTER STEAM BOILER WORKS

WM. ALLEN SONS CO., Proprietors

GREEN, PLYMOUTH AND WASHINGTON STS. : WORCESTER, MASS.

"BRETON" MINEROL "F"

BORNE, SCRYMSER COMPANY
80 South Street, New York

BOSTON

PHILADELPHIA

Works: Elizabethport, N. J.

PRODUCTION RESUMED

Last February our Works, located at Burrage, Mass., were destroyed by fire. Rebuilding has now proceeded far enough to enable us to resume the production of Sulphur Black; the manufacture of other colors and chemicals is well under way.

Sulphur Black is the most important color for the American textile industry; we know that our Sulphur Black is the only color of its kind made in America that equals and surpasses in quality the best that mills were accustomed to use prior to the World War. Therefore, this Company, owned and manned without exception by Americans, considers it not only good business, but a duty to its customers, to resume the manufacture of a color, the absence of which would place the American Textile industry at a disadvantage in the markets of the world.

Our productive capacity is sufficient to care for the needs of the American Textile industry; in doing this, quality of product will dominate our efforts.

Atlantic Dyestuff Company

SALES OFFICES:

BOSTON
88 Ames Bldg.

PHILADELPHIA
1530 Real Est. Trust Bldg.

NEW YORK
230 West 13th St.

CHARLOTTE
706 Com. Nat. Bank Bldg.

PROVIDENCE
334 Westminster St.

CONTENTS FOR JULY

Misbranding of Merchandise 11
 More Imperative than Food 12
 System for the Repair Shop 12
 The Identification of Textile Fibers 13
 French Worsted Drawing 15
 The Mechanics of Textile Processes 16
 Air Moistening in Textile Mills 17
 The Construction of Weaves 18
 Power Transmission in Textile Mills 19
 Foreign Language Study 20
 Practical Fixing of Cotton Looms 21
 "Straight Line" Textile Calculations 22
 Boiling-Off Silk 23
 The Lighting of Textile Mills 24

QUESTIONS AND ANSWERS 25

Calculating Change Gears for Looms
 Analyzing Cloth

KNITTING DEPARTMENT 26-27

The Manufacture of Knit Goods
 Attachment for Hosiery Machine

DYEING, BLEACHING AND FINISHING 28-29

The Process of Carbonizing
 Oxygen in Sodium Peroxide
 Dyeing Variegated Yarn

"HURRICANE" DYEING, DRYING AND FINISHING MACHINERY, PRESSES, ETC.

**"Hurricane" Carbonizing Equipments
 For Raw Stock and Cloth**

The illustration shows the "Hurricane" Dryer and Carbonizer for Raw Stock and Rags. We also manufacture a complete continuous system for Carbonizing in the piece. This consists of a saturating and squeezing machine operating in conjunction with a Drying and Carbonizing machine.

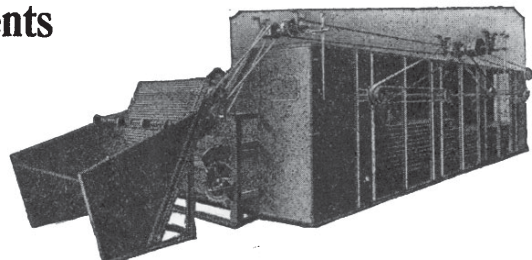

SEND FOR DESCRIPTIVE LITERATURE
 Drying—The "Hurricane" Way—Less Cost

Automatic Dryer and Carbonizer for Raw Stock

THE PHILADELPHIA DRYING MACHINERY CO.
 MAIN OFFICE AND WORKS: STOKLEY ST. ABOVE WESTMORELAND, PHILADELPHIA, PA.

DU PONT AMERICAN INDUSTRIES



Sulphogene Blacks

GX, BX, AX

Sulphur Blacks are among the most important dyestuffs used in the cotton industry for obtaining fast blacks. In purchasing these products cotton manufacturers and dyers should give careful consideration to the following features now offered in the Sulphogene Blacks being manufactured by this company on a very large scale.

SHADE—The range of shades offered is such as to satisfy the various requirements—for a greenish cast, Sulphogene Black GX, for a bluish cast, Sulphogene Black BX, and for a reddish cast, Sulphogene Black AX.

☞ *Quality*—The entire manufacturing process is under thorough laboratory control, thus insuring, in every delivery, absolute uniformity in strength and shade, and freedom from those properties likely to cause tendering of materials or spontaneous combustion.

☞ *Quantity*—This product is being manufactured in sufficient quantity to furnish immediate and ample supplies for all requirements and at all times.

☞ *Price*—The price is based on the current cost of raw materials and production. It is fixed as low as possible in order to secure the widest sale and to retain and increase the economies resulting from large scale manufacture.

E. I. du Pont de Nemours & Co.

Dyestuffs Sales Dept.

Wilmington ∴ Delaware

Branch Offices:

New York Boston Providence
 Philadelphia Chicago
 Charlotte, N. C.

DU PONT

TEXTILES

VOL. XV

JULY, 1919

NO. 1

MISBRANDING OF MERCHANDISE.

The misbranding and misrepresentation of merchandise are abuses that still bear heavily on the consumers and the honest merchants and manufacturers of the country. Some relief has been afforded by the Federal Trade Commission, but that Commission is already overburdened with work and furthermore lacks the power to apply the necessary remedies in the innumerable cases that are constantly arising in all parts of the country in connection with the misbranding and misrepresentation of merchandise, many of which involve small transactions which are nevertheless burdensome on the consumers.

What is needed is effective legislation that will protect the purchasers of all kinds of merchandise in all parts of the United States, whether at wholesale, at retail, between different States or within the boundaries of any one State. For the attainment of these objects uniform legislation is needed by Congress and all of the States, because United States laws of this kind cannot reach intrastate commerce. If the States took the lead in enacting laws against misbranding and misrepresentation the chances are that eventually there would be forty-eight kinds of legislation by the forty-eight States. If on the other hand a model law against misbranding and misrepresentation should be enacted by Congress, the great advantage of uniformity throughout the country would be secured at once so far as interstate commerce is concerned, and the United State law would exert a powerful influence in bringing about identical or similar legislation by the various States.

The bills to attain these objects that have been introduced in Congress and State Legislatures are of two kinds: (1) Those which, like the so-called "shoddy" bills, require certain classes of goods to be labeled to indicate the quality, composition or other feature of the merchandise; (2) Those which, like the British Merchandise Marks Act, forbid the false labeling of merchandise.

Although no bill of the first named class has ever become a law and been tested by experience, it has been proved repeatedly that this kind of legislation would not only be unworkable, but would place a burden on honesty and a premium on misrepresentation and fraud because of the impossibility of detecting violations. For example, the honest manufacturer selling goods made of 75 per cent. of wool and 25 per cent. of shoddy would so label them, while the dishonest manufacturer could place the label "All New Wool" on goods made of 25 per cent. of wool and 75 per cent. of shoddy without the possibility of having the deception exposed.

Legislation of the second named class, however, occupies a different footing. Its workability is not only evident to all who will study the question carefully, but has been demonstrated by an experience with the British Merchandise Marks Act, which for thirty-two years has prohibited under penalty of fine and imprisonment the false trade description of goods offered for sale in the United Kingdom, and which has been extended with equal success to most if not all of the British dominions and colonies.

The discussion of this question of misbranding during the past twenty years has made the merits of the British Act known in the United States, and as a result a bill patterned closely after the British law was introduced in the House in

1916, by Congressman A. W. Barkley, of Kentucky. Mr. Barkley has introduced this bill with an unimportant change at the present session and it is now pending before the House Committee on Interstate and Foreign Commerce. The main provisions of the Barkley Misbranding Act, as it is called, are summarized as follows:

1. Makes misbranding in interstate or foreign commerce a misdemeanor punishable by fine or imprisonment or both, unless goods are marked by order of a foreign purchaser in accordance with the laws of the foreign country to which it is shipped.

2. Rules and regulations for administering the law to be made by the Secretary of Agriculture. Examination of specimens of goods bearing suspected marks to be made by the Bureau of Standards.

3. Secretary of Commerce to refer the Bureau's findings of misbranding to the proper U. S. district attorney, who is required to prosecute the accused.

4. Goods are deemed misbranded under the Act:

(a) If an imitation of or under the name of another article.

(b) If contents of package have been removed and other contents substituted.

(c) If contents of package are not plainly and correctly stated in terms of weight, measure, numerical count or quality.

(d) If goods bear any false or misleading mark as to weight, measure, numerical count, State or country in which they are manufactured, materials of which they are composed, mode of production, patent or copyright, name of manufacturer, quality, trade name or other particular.

(e) If goods have been misrepresented in an advertisement.

5. No dealer to be prosecuted if he can establish a guaranty of the mark by the wholesaler, jobber, manufacturer or other party from whom goods were purchased.

6. Condemned goods to be sold and proceeds paid into Treasury of United States.

7. Misbranded goods when offered for import to be refused admission and to be destroyed if not reexported within three months.

There are defects of omission and commission in the Barkley bill which should be remedied by amendments, and to which we will call attention at another time. But it deserves favorable consideration, because based in the main on the right principle.

MORE IMPERATIVE THAN FOOD.

"Sixty-five tons of knitting yarn, originally purchased by the American Red Cross for the making of socks and sweaters for American soldiers, has been manufactured into 78,000 yards of cloth and 33,000 shawls, fifty inches square, and shipped abroad to help provide for the destitute war sufferers of Europe.

"The shawls are especially heavy. The cloth consists of 50,000 yards, all wool, for blankets and heavy garments, and 28,000 yards, eighty inches wide, with a cotton warp.

"In addition, the American Red Cross has since the first of the year shipped 1,060,617 pounds of yarn and more than 22,500,000 yards of material for the making of garments—textiles valued at \$11,295,141, and including dress goods, cotton flannel, outing flannel, bathrobing, bleached and unbleached cotton sateen, twill jeans and gingham. Large quantities of buttons, hooks and eyes, thread, needles and similar accessories have also been shipped.

"This material will be used in France or sent to Belgium, Poland and the Balkan States, where most needed, and will

TEXTILES

be fashioned into garments by the people who are to receive it.

"It is estimated that the German invasion of France and Belgium alone made wanderers of 1,250,000 formerly happy country people, and Red Cross investigators have reported the need for clothing among these and other war sufferers as being more imperative than food."

The above item was sent to TEXTILES by the American Red Cross with a request to publish, evidently without the slightest realization that it was conclusive evidence of mismanagement of those in charge of that organization. The readers of TEXTILES will recall our exposure of the waste of hand-knitting when the craze assumed serious proportions in 1917. In spite of our private and public appeals to stop the waste, the head officials of the Red Cross refused to change their policy until compelled to do so by an order of the Government in

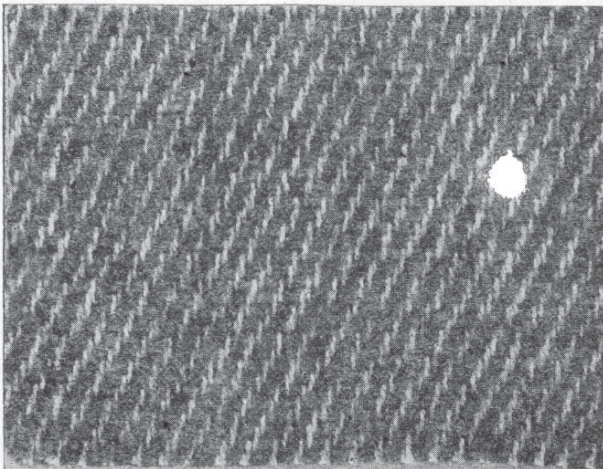

MORE IMPERATIVE THAN FOOD.

August, 1918, a few weeks after our exposure has been sent to every part of the United States by the Literary Digest.

The waste and extravagance in the hand-knitting of the yarn are also found in the disposal of the tons of odds and ends by their manufacture into cloth and blankets. We submitted samples of the Red Cross cloth and blankets to leading firms in the trade and were informed that the market values of goods to serve the same purposes were \$5 for the 4-pound blanket and \$3 per yard for the cloth. The blanket fabric is made of the 4-ply worsted yarn which was sold to hand-knitters at what was claimed to be cost, \$2.80 per pound. This makes the yarn alone cost \$11.20 per blanket, to which must be added the cost of weaving, finishing and waste in these processes, in order to reach the total cost of the Red Cross blanket of which the market value is \$5.00.

The 29-ounce cotton warp cloth, shown in the illustration, is composed of 28 per cent. of warp and 72 per cent. of worsted filling. At 60 cents per pound for the warp and \$2.80 per pound for the worsted the yarn alone costs \$3.97 per yard. To this must be added the cost of weaving, finishing and waste in order to reach the total cost of a fabric with a market value of \$3.00 a yard.

Great as is the loss in disposing of the tons of odds and ends by manufacturing these goods, it is far less than that involved in the original plan of knitting the yarn by hand, for the hand-knitted goods not only cost much more, but were of little or no use for the war service for which they were made.

Never in the history of the world has there been greater need of clothing to relieve human suffering than at the present time, and never so far as we can learn has there been more wasteful and inefficient methods of wool manufacturing than in the production of these knitted and woven fabrics of the Red Cross.

SYSTEM FOR THE REPAIR SHOP.

Waste and extravagance are sure to result if the mill manager does not keep close track of the repair work by the machinists and woodworkers in a textile mill. He should know, not only how many men are employed, their wages and the total pay roll in the repair shops, but also for what departments of the mill their work is done. In this way the manager can locate the cause of any excessive

REPAIR SHOP

WEEK ENDING Jan 17 19PRICE .35, .40, .45, .70NAME Pro. Born, W. Smith, J. G. Jones, R. E. Bell.

	Sun.	Mon.	Tues.	Wed.	Thurs.	Fri.	Sat.	Total Hours	Rate	AMOUNT
Picking		2		3			2	7	40	2 80
Carding			2	1		1	3	7	40	2 80
Drawing		3	1		4	5	1	14	35	4 90
Slubbers				1		2		3	35	1 05
Intermediates					2		1	3	45	1 35
Fine Speeders			1	2		2	1	6	45	2 70
Warp Spinning		1	2	3		2	3	11	40	4 40
Filling Spinning		2		2	1			5	45	2 25
Twisting				1	3			4	45	1 80
Beaming		1	1			2		4	45	1 80
Spooling						3		3	45	1 35
Warping		2	3	1			2	8	40	3 20
Slashing							5	5	70	3 50
Web Drawing Mch.		3	1	2				6	40	2 40
Web Drawing Hand					3			3	45	1 35
Weaving		4	3	5	5	3	2	22	45	9 90
Cloth Room				3				3	40	1 20
Water Wheel	10			1			1	12	70	8 40
Power	9		1			2	1	13	70	9 10
Elec. Power	10	1		1	4		4	20	70	14
Mill Buildings	3		1					4	35	1 40
Village		5	4					9	40	3 60
										85 25

cost for repairs. Sometimes it is due to bad management in the repair shop itself. At other times it is the fault of the overseers who call on the repair shop to do work in the various departments.

The blank form shown this month is made out by the master mechanic and sent to the manager's office at the end of each week. It shows the number of hours spent on repair work each day for each department, the weekly total hours, rate of wages per hour, total wages for each department.

The Identification of Textile Fibers

By Dr. Louis J. Matos

[The object of these articles is to give mill men in a concise form free from unnecessary technicalities, a complete description of the testing of fibres. The illustrations will consist of original drawings made by the author from actual mounts forming part of an extensive series of tests. Dr. Matos' high reputation as a textile chemist and chemical engineer is a guarantee as to the value of this work. He will be pleased to co-operate with anyone interested in making tests, and reply to any questions regarding the subject.—Ed.]

The fibres used in the textile industry have increased greatly in number during the last twenty years. From time to time there have been discovered and gradually developed to commercial importance fibres of various kinds that adapt themselves to certain specific uses in the manufacture of fabrics. This multiplicity of fibres has been the prime cause for the development of methods which enable one

is commonly employed for fibre work. For the ordinary work of the mill it should be equipped with a quarter-inch and a one-inch objective, together with a one inch and a two inch eye-piece. The microscope should be equipped with a fixed stage and a concave mirror. The principal accessories for microscopic work consist of glass slides 3" x 1", Fig. 1, of which a dozen will be a sufficient supply. There will also be required a number of thin oblong cover glasses 3/4" x 1 1/2", a few teasing needles, which may readily be made by taking a few fine sewing needles and carefully inserting the eye end in a piece of soft wood about the size of a lead pencil, Fig. 2, a pair of fine pointed steel tweezers, Fig. 7, and a number of plain white china dishes, which serve for wetting the fibres under examination.

The chemical reagents for testing the various fibres include the following, which may be com-

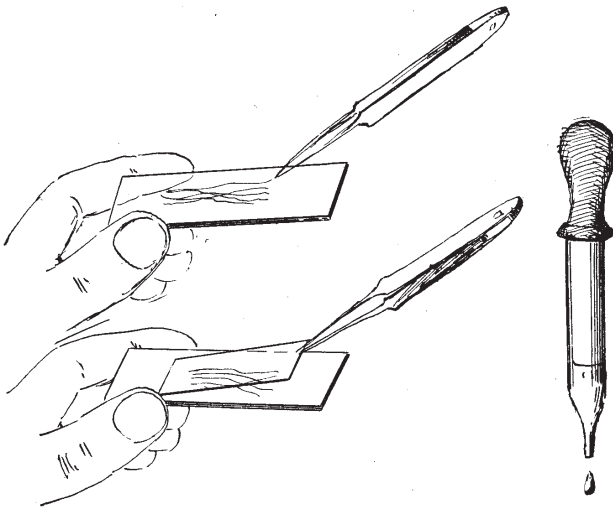
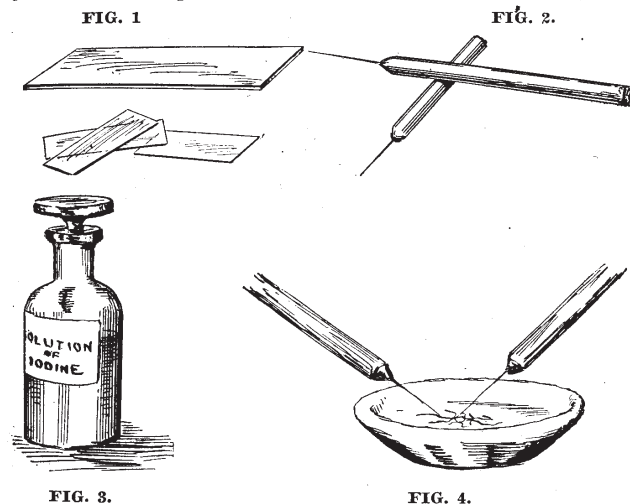

to identify with more or less exactness the more important fibres and to compare one fibre with another.

Three important groups of fibres are recognized at the present time, vegetable, animal and artificial. The vegetable fibres most commonly used are cotton, flax, hemp jute, ramie and a few others of lesser importance. The animal fibres comprise wool, hair and natural silk, that is, silk from the silk worm, of which there are several varieties. The artificial fibres are artificial silk of various kinds and artificial hair, which is in fact a very coarse artificial silk.

The identification of fibres presents no great technical difficulty, but the methods should be thoroughly understood at the beginning. The operator should have experience in identifying fibres of known origin by methods that have been thoroughly worked out beforehand. For example, if one has never studied the physical or chemical properties of cotton, it would be impossible for him to state with certainty that a given fibre is cotton. The same applies to other fibres. It becomes necessary, therefore, for one undertaking fibre work to make a more or less thorough study of the important fibres of each group and to make a careful comparison of one with the other.

Two methods that are used jointly in identifying fibres are based upon the use of the microscope and a few simple accessories. The compound microscope

pounded by a friendly druggist if the operator does not feel sufficiently qualified to prepare them. These reagents should be contained in two ounce glass stoppered bottles, Fig. 3, with the exception of No. 6, the stopper of which should be rubber:

LIST OF REAGENTS.

No. 1. Solution of Iodine:		
Potassium iodide		1 gram
Water		100 c.c.
Iodine		5 grams
No. 2. Glycerine and Sulphuric Acid Mixture:		
Concentrated sulphuric acid		30 c.c.
Pure glycerine		20 c.c.
Distilled water		10 c.c.
No. 3. Zinc Chloride and Iodine Solution:		
Iodine		2 grams
Potassium iodide		10 grams
Zinc chloride		60 grams
Dissolved in water		28 c.c.

- No. 4. Ammoniacal Copper Hydroxide Solution:**
Copper hydroxide is precipitated, filtered off and dissolved in concentrated ammoniacal. Keep in the dark.
- No. 5. Beta-Naphthol Solution:**
Beta-Naphthol 2 grams
Alcohol 40 c.c.
- No. 6. Caustic Soda Solution 10%:**
Caustic soda 10 grams
Water 90 c.c.
- No. 7. Nitrating Acid:**
Concentrated nitric acid 50 c.c.
Concentrated sulphuric acid 50 c.c.
- No. 8. Rosaniline Solution:**
Crystal fuchsine ½ gram
Water 50 c.c.
Boil and decolorize by adding either a few drops of caustic soda solution or concentrated ammoniacal, and filter.
- No. 9. Glycerinated Ammoniacal Copper Solution:**
Sulphate of copper 10 grams
Water 100 c.c.
Glycerine 5 grams
Add caustic soda until the precipitate which forms is redissolved.
- No. 10. Aniline Sulphate Solution:**
Aniline sulphate 1 gram
Water 100 c.c.
- No. 11. Phlorogucine Solution:**
Phlorogucine ½ gram
Distilled water 100 c.c.
- No. 12. Iodine and Sulphuric Acid:**
A fragment of iodine is dissolved in alcohol and water is added until the solution is light yellow. The fibre to be examined is moistened with a solution of sulphuric acid 1:2, and then with the iodine solution.
- No. 13. Fuchsine Solution:**
Fuchsine crystals 5 grams
Alcohol 95% 100 c.c.
- No. 14. Lead Acetate Solution:**
Lead acetate 5 grams
Water 100 c.c.
- No. 15. Picric Acid Solution:**
A saturated water solution of picric acid.
- No. 16. Basic Zinc Chloride Solution:**
Zinc chloride 100 grams
Water 85 c.c.
Zinc oxide 40 grams
Boil until the solution is complete.
Boil until the solution is complete.

To this list of reagents there may be added a few others, mention of which will be made in subsequent articles.

The method commonly adopted for examining fibres is to separate the fibres by the aid of the testing needles and tweezers until several fibres are isolated. This is best done in a few drops of water in one of the china dishes, Fig. 4. In the case of yarns a short section should be untwisted while wet with water or a little glycerine, and the thread then pulled apart with the needles while immersed. A glass slide is then carefully cleaned and by means of the tweezers one or two of the fibres are removed from the butter dish and laid lengthwise in the centre of the glass, Fig. 5. With the aid of an ordinary medical dropper, Fig. 6, a few drops of reagent No. 2 are placed upon the slide and one of the thin cover glasses carefully placed over the fibres, lowering it so that no water bubbles appear, Fig. 7. Any excess of solution that is squeezed out may be removed

by means of a small piece of filter or blotting paper, as shown at Fig. 8. The slide is then ready to be placed on the stage of the microscope and examined.

After repeating the operations above described several times, the operator will acquire facility in isolating fibres for examination, since it is manifestly impossible to arrive at any reliable conclusion in examining fibres when they are placed on the slide in compact bunches. It is better to make several slides of suspected fibres rather than to overcrowd a single slide with a large number of fibres.

When chemical reagents are to be applied to a fibre two methods are commonly used. One is first to isolate the fibres in a butter dish with the aid of pure water and the testing needles. When a sufficient number have been separated, they may be removed to a second butter dish in which the several reagents are added. The other method is to isolate the fibres in water as above indicated, transfer a few of them to the glass slide, place the cover glass in position, then apply successively a few drops of the desired chemical reagent at one end of the cover glass and by means of a small triangular clipping of filter paper soak up the reagent from the other end

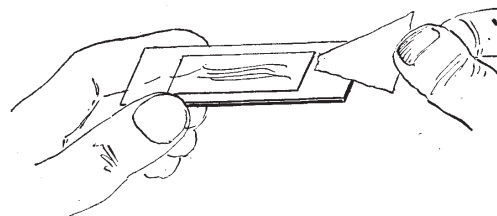

FIG. 8.

of the cover glass. By this means the water originally on the slide is gradually displaced by the reagent. It should be noted that in making tests with chemical reagents, the fibres are tested with each reagent separately instead of adding one reagent after another to the same fibre. In adding chemical reagents to textile fibres the principal point to note is the influence that the reagent has on the physical properties of the fibre and also whether or not the fibre is changed in color.

The preceding remarks apply to all fibres. The specific reagents are applied as occasion requires. For example, if a fibre dissolves completely in caustic soda, the conclusion arrived at at once is that it is not a vegetable fibre, since vegetable fibres do not dissolve in caustic soda. If, however, the fibre is treated on the microscope slide with reagent No. 4 (ammoniacal copper hydroxide solution) and is seen to swell up, becoming thoroughly distorted and afterwards dissolving, the conclusion arrived at at once is that it is a vegetable fibre and not an animal fibre.

Some fibres, for example, cotton, when viewed under the microscope are identified at once without any specific tests. When the physical properties are recognized under the microscope, it is best to identify the cotton fibre by its characteristic twist and by the fact that one end of every cotton fibre is pointed while the other end is always open.

French Worsted Drawing

By Leon Faux

(A Series of Articles on French Worsted Spinning)

M. G. B. INTERSECTING GILLS.

Each set of fallers in the M. G. B. gill box, Fig. 108, consists of 27 elements, the faller being $\frac{1}{4}$ in. thick, $1\frac{1}{2}$ in. high over all, and a working height of $\frac{3}{4}$ in.

The row of pins are set in the center of the faller for working ordinary wools, and set to one side for short wools, Fig. 109.

The working zone of the pins is formed by 16 fallers of each set, or a total of 32 fallers. They operate with a progressive penetration of the layer of wool for a part of the

working distance. The working zone is shown at Fig. 109, $acoo'$. The progressive penetration takes place from o to a' by the inclination of the slides Ch . From a' to a the fallers move in a horizontal direction, so that the compression of the fibers is uniform throughout the area $aca'c'$.

The pitch of the working screws is uniform, that of the return screws gradually decreases in order to bring the faller into a vertical position in order to facilitate its entrance into the thread of the corresponding screw where it should enter. Other characteristics of this gill box are as follows:

The direct and reverse motions of the trumpet K^1 , which, instead of being driven by a cord and grooved pulley, is driven by a horizontal gear-rack 1 fastened to the carriage T and driving the pinion 2 fixed to a gear 3 driving pinion 5 of K^1 by connection through 4. This positive drive ensures equal movements of the trumpet forward and backward.

The cams on the screws are oiled by automatic devices in order to prevent the soiling of the machine by the spreading of the oil over the various parts, and to make sure of a constant lubrication to prevent wear of the machine.

Fig. 110 shows the can gill box built by Martinot

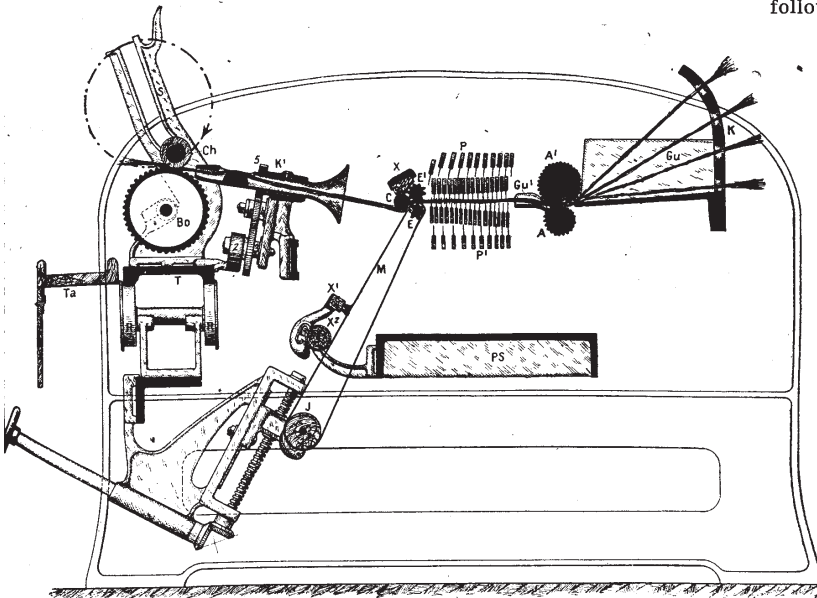

FIG. 108.—THE M. G. B. GILL-BOX.

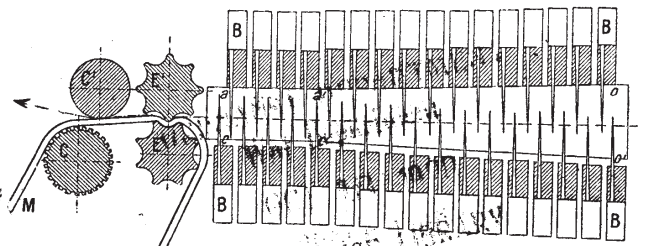

FIG. 109.—FALLERS FOR M. G. B. GILL-BOX.

and Galland. The sliver is run into the can as follows: The stationary, flat funnel K^1 reduces the volume of the sliver and guides it to the funnel K^2 , which condenses it into a round sliver or ribbon under the action of the drawing rolls $R R^1$. From these rolls the sliver is carried through the passageway Z of the can cover Cp . The passageway Z has a planetary motion which lays the sliver in spirals superimposed in the can. This facilitates its withdrawal in good condition, even when the wool is short.

TEXTILE COLOR CARD.

The Fall 1919 Season Card recently issued by The Textile Color Card Association, 354 Fourth Av., New York, has been in such demand as to necessitate the Association putting out a pocket edition of the card. The colors, thirty-two of which are in silk and ten in wool, are exact duplicates of those on the regular season edition. In place of the usual cloth binding, this new card is made of lightweight cardboard with the ribbons and woolen samples cut and pasted to the card.

It has been pointed out that the advantages of a card of this kind are many. Convenient to carry and easy to mail, they will be found suitable by those needing quantities of cards for distribution purposes, especially in the exporting trade, where the American Cards are now being used extensively.

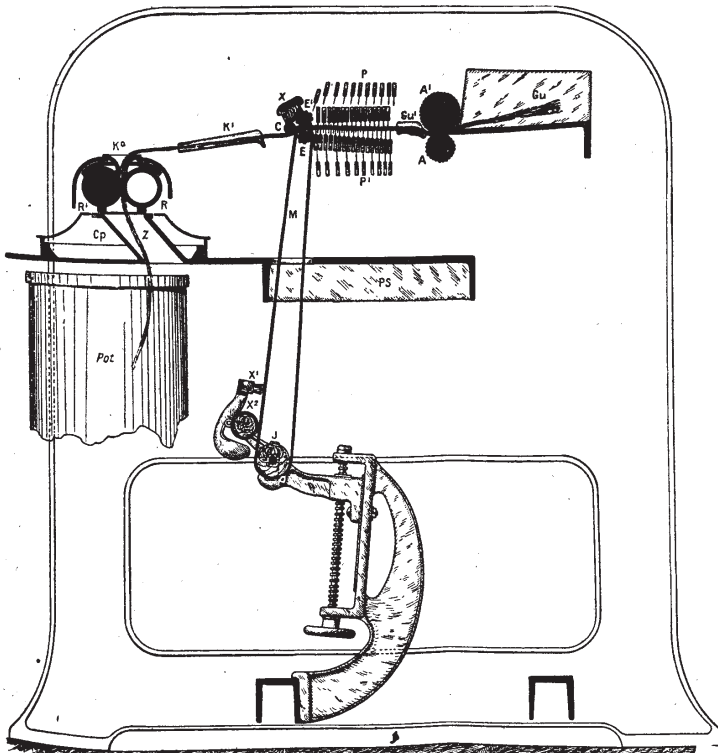

FIG. 110.—MARTINOT AND GALLAND GILL-BOX.

The Mechanics of Textile Processes

By W. Scott Taggart

Ex.—A beam (neglect its weight) is 16 ft. long between its supports. Weights of 5, 3 and 7 tons are placed so that the 5 tons is 4 ft. from the left-hand support, the 3 tons is 6 ft. from the left support, and the 7 tons is 7 ft. from the right support. What is the pressure on each support?

First find the pressure on support A, Fig. 131. Let x = this pressure. This means that we must find the moments of the forces round B. As the pressure on A acts upwards it will tend to turn the beam clockwise round B, so will be posi-

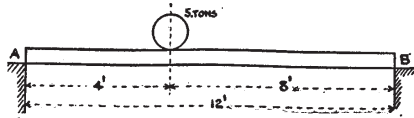

FIG. 131.

tive, or +. The three weights will all tend to turn the beam anti-clockwise round B, so the moments will be negative, or —.

$$\begin{aligned} \text{Moments of A will} &= x \times 16 \text{ ft.} = 16x \text{ ft. tons.} \\ \text{" 5 tons " } &= 5 \times 12 \text{ " } = 60 \text{ ft. tons.} \\ \text{" 3 " " } &= 3 \times 10 \text{ " } = 30 \text{ " " } \\ \text{" 7 " " } &= 7 \times 7 \text{ " } = 49 \text{ " " } \\ 16x - 60 - 30 - 49 &= 0 \\ 16x &= 139 \\ x &= 8 \frac{11}{16} \text{ tons.} \end{aligned}$$

So that the pressure on A = $8 \frac{11}{16}$ tons.
and " " B = $15 - 8 \frac{11}{16} = 6 \frac{5}{16}$ tons.

Ex.—A beam 10 ft. long is supported at a point 3 ft. from

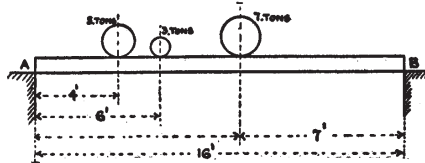

FIG. 132.

one end. If a weight of 3 tons is placed on one end, what force must be applied at the other in order to obtain a balance? Neglect the weight of the beam.

Sketch the conditions of the problem as in Fig. 133. F is clearly the point round which the beam will turn if any movement takes place. The 3 tons at A will turn it anti-clockwise, and the x tons at B will turn it clockwise, so that the moment of the 3 tons round F—the moment of x tons round F = 0.

$$\begin{aligned} (3 \text{ tons} \times 3 \text{ ft.}) - (x \text{ tons} \times 7 \text{ ft.}) &= 0. \\ 3 \text{ tons} \times 3 \text{ ft.} &= x \text{ tons} \times 7 \text{ ft.} \\ 9 &= 7x \\ x &= 1 \frac{2}{7} \text{ tons weight at P.} \end{aligned}$$

The whole of the weight on the beam will be supported by F, so that F is carrying $3 + 1 \frac{2}{7} = 4 \frac{2}{7}$ tons.

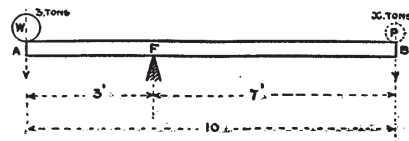

FIG. 133.

Ex.—A bent lever as in Fig. 134 is weighted at A by a freely hanging weight of 20 lb. What weight, hanging from B, will balance the lever if AF is 12 in. and BF is 6 in. long? AF is inclined to the horizontal at 45° and BF at 60°.

First draw the lever to scale, as in Fig. 134, to the particulars given in the question. Both weights W and P will hang vertically. The distance they act from the fulcrum F will be measured on a line through F at right angles to the direction in which the weights are acting. This line is CFD. The moment of weight W round F will therefore be Wx , and the moment of weight P round F will be Py .

$$\begin{aligned} \text{Then } Py - Wx &= 0 \\ Py &= Wx \\ P &= Wx \div y. \end{aligned}$$

$W = 20$ lb. By scale it is found that $x = 8 \frac{3}{4}$ in. and $y = 3$ in. The weight P must be calculated.

$$\begin{aligned} P &= (20 \times 8 \frac{3}{4}) \div 3 = (20 \times 67) \div (3 \times 4) \\ P &= 55.8 \text{ lbs.} \end{aligned}$$

The examples just given arise out of the general question of equilibrium and the moments of a force. Experiments were previously made to prove the laws of equilibrium, and the reader may feel confident that the methods adopted in the examples are correct because they are based on these laws. It is, however, an easy matter to verify, by trial, answers to most questions that may be asked, and readers are strongly recommended to find an answer experimentally and then test the answer by the law.

A very simple arrangement can be fitted up for experiments on beams, rods, levers, etc. Fig. 135 will give the

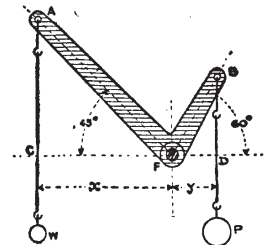

FIG. 134.

general idea. Careful measurements of distances and exact notes of the weights and readings of the spring balances are, of course, absolutely necessary in all these experiments.

Fig. 136 illustrates the arrangements for experiments on levers. A stud F is fixed in the upright board and a rod AB bored at the center to fit the stud F loosely. If AB is made long enough it can be used for a variety of purposes.

Ex. A weight of 12 lbs. is placed 13 in. from the center

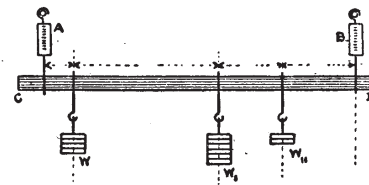

FIG. 135.

F in Fig. 136. How far from F must a weight of 28 lbs. be placed so that the rod AB is balanced?

First place the weight W of 12 lbs. at 13 in. from F. Now slide a weight of 28 lbs., P, until AB remains horizontal. Measure its distance from F and the problem is solved. Compare the result by calculating the position of P by the principle of movements.

As the lever is in a balanced condition it is in equilibrium.

$$\begin{aligned} W \times x &= P \times y \\ (12 \times 13) &= (28 \times y) \\ (12 \times 13) \div 28 &= 5.57 \text{ in.} \end{aligned}$$

The weight P is therefore hung 5.57 in. from F.

During the experiment the reader will observe that the

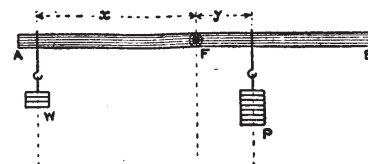

FIG. 136.

lever AB will balance in any position, so naturally the moments round the center F will always equalize each other.

Baling Press.—Spencer & Cook Ltd., Stalybridge, Eng. An improved press for baling cotton, wool, waste, felt, rags, paper and like materials. Ease of operations, high density, economy of power and durability are among the claims made for it.

Air Moistening in Textile Mills

In the June issue of TEXTILES we gave a tabulation of the moisture regain, as determined by Schloesing, for silk at the three temperatures, 54°, 75° and 95° and at each degree of relative humidity from 1 to 95 per cent., also a chart showing the moisture in silk in process of manufacture during March, April and May in a mill heated to 70° when the outside temperature falls below that point and without artificial moistening of the air, the data being obtained from Schloesing's tables and the U. S. Weather Bureau observations at New York, for the year ending February, 1918. The accompanying chart shows the moisture regain for silk under the same mill conditions for June, July and August of the

moisture regain of 23.5 parts per 100 parts of dry silk. At this time the daily fluctuations are particularly violent, as will be seen by referring to Aug. 24, with a regain of 13.8 parts in the forenoon and 23.5 parts in the afternoon.

These figures show plainly without further explanation the effect of the weather on the moisture in silk in process of manufacture, and the necessity of keeping the relative humidity of the air uniform in the work rooms in order to obtain uniform results in manufacturing silk goods.

The accompanying table gives the readings of Schloesing chart of moisture regain for cotton for the three temperatures, 54°, 75° and 95°, at relative humidities from 1 to 96

Moisture Regain for Cotton

At 54°, 75° and 95° F., and Relative Humidity from 1 to 95%.											
%	54°	75°	95°	%	54°	75°	95°	%	54°	75°	95°
1	.45	.40	.35	20	3.80	3.58	3.46	39	5.47	5.08	4.80
2	.81	.75	.70	21	3.90	3.68	3.52	40	5.53	5.15	4.86
3	1.14	1.07	1.01	22	4.00	3.75	3.60	41	5.62	5.22	4.91
4	1.40	1.32	1.26	23	4.10	3.85	3.67	42	5.70	5.31	4.98
5	1.64	1.55	1.49	24	4.20	3.93	3.75	43	5.78	5.40	5.07
6	1.90	1.80	1.73	25	4.28	4.00	3.82	44	5.83	5.48	5.12
7	2.10	2.00	1.93	26	4.35	4.05	3.90	45	5.92	5.53	5.20
8	2.25	2.18	2.10	27	4.47	4.07	3.98	46	6.00	5.63	5.27
9	2.42	2.32	2.27	28	4.55	4.23	4.05	47	6.07	5.70	5.32
10	2.57	2.50	2.40	29	4.62	4.32	4.12	48	6.12	5.80	5.42
11	2.72	2.66	2.52	30	4.70	4.40	4.20	49	6.23	5.87	5.52
12	2.87	2.80	2.67	31	4.80	4.50	4.26	50	6.32	5.92	5.60
13	3.00	2.90	2.80	32	4.88	4.57	4.33	51	6.40	6.02	5.67
14	3.15	3.00	2.90	33	4.96	4.63	4.40	52	6.48	6.10	5.76
15	3.27	3.10	3.00	34	5.02	4.72	4.46	53	6.58	6.18	5.87
16	3.38	3.20	3.10	35	5.11	4.80	4.52	54	6.68	6.27	5.95
17	3.50	3.30	3.17	36	5.20	4.87	4.60	55	6.77	6.35	6.02
18	3.60	3.40	3.27	37	5.28	4.92	4.65	56	6.86	6.45	6.10
19	3.70	3.50	3.35	38	5.38	5.00	4.72	57	6.98	6.52	6.20
								58	7.08	6.60	6.30
								59	7.20	6.70	6.38
								60	7.30	6.80	6.47
								61	7.42	6.90	6.58
								62	7.52	7.00	6.67
								63	7.67	7.12	6.78
								64	7.80	7.23	6.90
								65	7.92	7.32	7.00
								66	8.03	7.48	7.12
								67	8.18	7.60	7.22
								68	8.33	7.72	7.36
								69	8.46	7.87	7.50
								70	8.62	8.00	7.62
								71	8.80	8.18	7.78
								72	8.98	8.35	7.92
								73	9.16	8.50	8.07
								74	9.38	8.70	8.22
								75	9.58	8.88	8.40
								76	9.78	9.07	8.58
								77	10.00	9.30	8.78
								78	10.22	9.50	8.97
								79	10.50	9.72	9.05
								80	10.78	10.00	9.35
								81	11.07	10.25	9.22
								82	11.40	10.57	9.92
								83	11.70	10.90	10.21
								84	12.07	11.22	10.55
								85	12.40	11.60	10.85
								86	12.80	12.00	11.22
								87	13.30	12.40	11.60
								88	13.80	12.90	12.00
								89	14.45	13.40	12.48
								90	15.00	14.07	13.00
								91	15.60	14.85	13.72
								92	16.30	15.72	14.60
								93	17.10	16.60	15.60
								94	18.00	17.60	16.60
								95	19.00	18.70	18.20

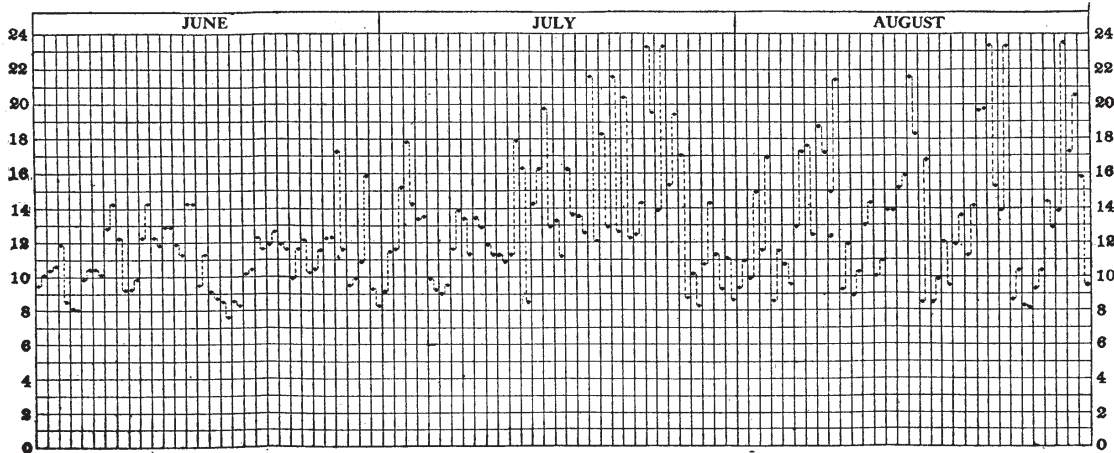

DAILY FLUCTUATIONS OF MOISTURE IN SILK IN PROCESS OF MANUFACTURE.

same year. The moisture regain for the spring months showed wide fluctuations from day to day and between forenoon and afternoon, but remained during the season within these extremes: the lowest, 2.6 parts of water to 100 parts of dry silk on March 6; and the highest, 10.4 parts of water on April 21. Wide apart as are these extremes they appear moderate when compared with those reached in the summer and winter. The accompanying chart continues the exhibit through the summer months, June, July and August, during which the same wide fluctuations occur from day to day and between forenoon and afternoon, but with a pronounced rising tendency which culminates in the latter part of August, the extreme being reached on August 23, 24 and 29 with a

per cent. This is the first tabulation of Schloesing's data ever published. Next month we will give the tabulation of the moisture regain for wool, thus completing the series for silk, cotton and wool.

Cleaning Motion for Card Flat-Brush.—Dronsfield Bros. Ltd., Oldham, Eng. An improved cleaner for card-flat brushes. It consists of two motions, a reciprocator attached to the brush-roller shaft and imparting a slow lateral traverse to the brush, and oscillating brackets which swing the brush-comb in and out. The advantages are cleaning of the card-covered surface of the flats and thorough cleaning of the bristles.

The Construction of Weaves

By E. Bittner

FIGURED WEAVES.

If risers are inserted in or removed from a weave the weave effect loses its original character, and in these places the floats of the threads are lengthened or shortened, pro-

Fig. 493

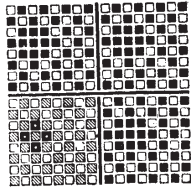

Fig. 494

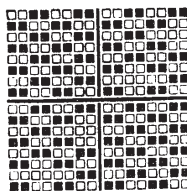
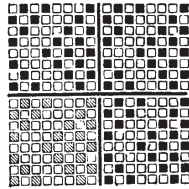

FIG. 497.

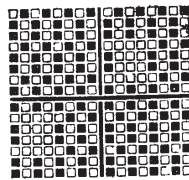

FIG. 498.

ducing a figured effect. The plain rib, twill and satin weaves are used for figured weaves.

In drafting a figured effect on a plain weave the latter is drafted on a certain number of warp and filling threads, and risers are then inserted in accordance with

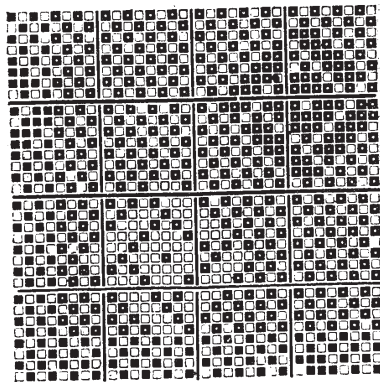

FIG. 496.

the selected motif, Figs. 493-496. These weaves on a plain ground are used for cotton, linen, silk and union fabrics.

The figured effects are drafted on rib, twill and satin weaves in the same way as on a plain ground, Figs. 497-507.

Fig. 493. Plain ground, 8x8. Risers added. Usually the filling float is on the face.

Fig. 494. Plain ground, 8x8. Risers removed for a zigzag effect.

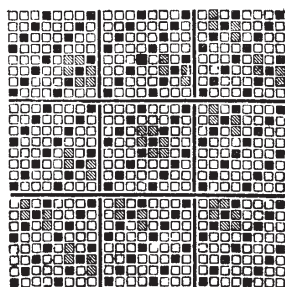

FIG. 495.

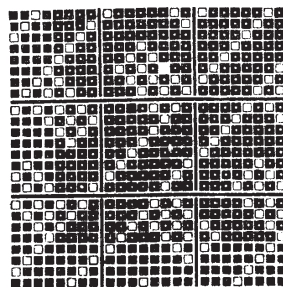

FIG. 501.

Fig. 495. Plain ground, 20x20.

Fig. 496. Plain ground, 28x28. Risers removed and added, giving a more pronounced pattern when the warp and filling are of contrasting colors.

Fig. 497. Rib ground, 16x16. Risers removed.

Fig. 498. Mixed rib ground, 16x15. Risers removed.

Fig. 499. Rib ground, 16x16. Risers added.

Fig. 500. Twill ground, 16x16. Risers added to for spots arranged in broken twill order.

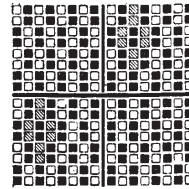

FIG. 499.

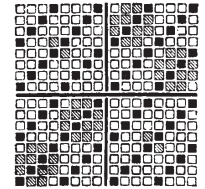

FIG. 500.

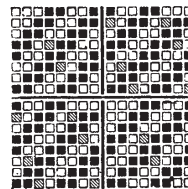

FIG. 502

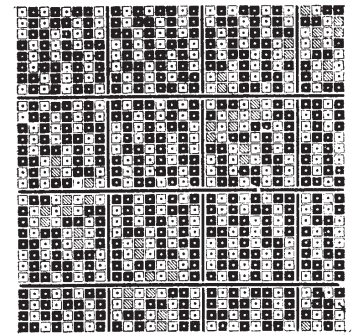

FIG. 507.

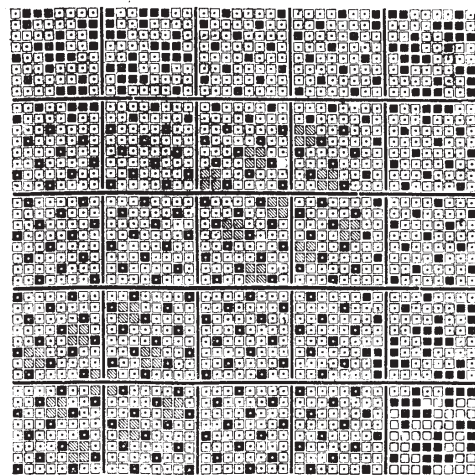

FIG. 503.

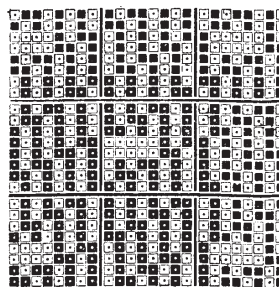

FIG. 505.

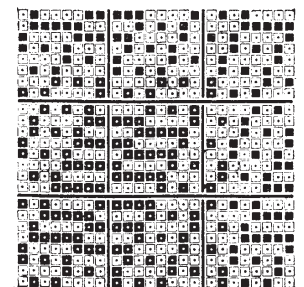

FIG. 506.

(Continued on next page)

Power Transmission in Textile Mills

By Charles L. Hubbard

The greatest admissible distance between bearings for shafts of varying size, limiting the deflection to $\frac{1}{80}$ -inch per foot of length, under the conditions of strain noted above, are given in Tables IV and V, which are for turned steel and cold-rolled steel respectively.

Ex. A turned line-shaft is to transmit 120 horse-power at a speed of 400 revolutions per minute. For a certain portion of its length it is free from pulleys, being used for transmission only. What size of shaft should be used and what is the limiting distance between bearings for that portion carrying no pulleys?

$$120 \div 4 = 30$$

Referring to Table II under turned lined-shafts, we find

TABLE IV. (Turned Steel Shafting). Limiting distance between bearings. Torsional strain only. No bending strain except from own weight.

DIAM. OF SHAFT	DISTANCE BETWEEN BEARINGS	DIAM. OF SHAFT	DISTANCE BETWEEN BEARINGS	DIAM. OF SHAFT	DISTANCE BETWEEN BEARINGS	DIAM. OF SHAFT	DISTANCE BETWEEN BEARINGS
1 1/2	7.5	2 1/2	10.5	3 1/2	13.1	5	16.6
1 5/8	7.9	2 3/4	10.8	3 7/8	13.4	5 1/4	17.2
1 3/4	8.3	2 3/4	11.2	3 3/4	13.7	5 1/2	17.6
1 7/8	8.6	2 3/4	11.5	3 7/8	14.1	5 3/4	18.3
2	9.	3	11.8	4	14.4	6	18.8
2 1/8	9.4	3 1/8	12.2	4 1/4	14.9	6 1/2	19.8
2 1/4	9.8	3 1/4	12.5	4 1/2	15.5	7	20.8
2 1/2	10.1	3 1/2	12.8	4 3/4	16.1	7 1/2	21.8

this number calls for a 3-inch shaft, and Table IV gives the limiting distance between bearing for a shaft of this size, used for transmission only, as 11.8 feet.

SHAFT AND PULLEY ARRANGEMENTS.

While the laying out of a system of shafting for a large mill is the work of an engineer, there are often cases where it is desirable to make changes or extensions without securities be considerably reduced by arranging the pulleys so as to neutralize the belt pull, a scheme sometimes possible for doing this is illustrated in Fig. 19.

THE CONSTRUCTION OF WEAVES.

(Continued from previous page.)

Fig. 501. Twill ground, 24x24. Risers added.

Fig. 502. Twill ground, 16x16. Risers added and removed.

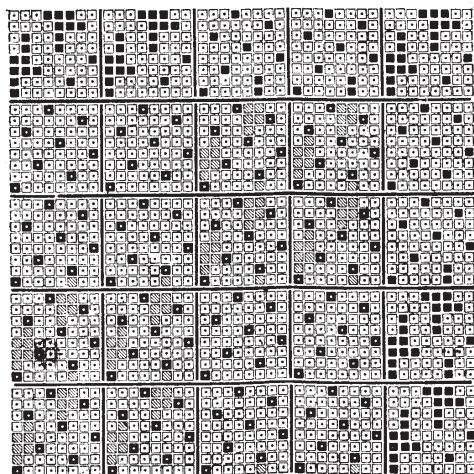

FIG. 504.

Fig. 503. Satin ground, 30x30. Risers added.

Fig. 504. Satin ground, 32x32. Risers added.

Fig. 505. Satin ground, 18x18. Risers removed.

Fig. 506. Satin ground, 18x18. Risers added.

Fig. 507. Satin ground, 28x28. Risers removed.

ing expert advice. The following suggestions, together with rules and tables, will be found of use in work of this kind.

Two common arrangements for laying out a line of shafting are shown in Figs. 17 and 18. If the line is very long there will be an inclination for it to twist at the extreme end, especially if much power is taken off. This condition may be greatly improved by arranging to supply the power at the center of the line as shown in Fig. 17.

For shorter lines, the power may be supplied at one end, as in Fig. 18 if more convenient. The general arrangements of bearings and couplings are shown in the illustrations. The head-shafts should be in a single piece of as short a span as possible, with the couplings outside the main bearings.

Line-shafts extend in both directions in Fig. 17 and in one direction in Fig. 18, reducing in size as power is delivered to the various counter-shafts or machines connected with them. Sometimes a friction clutch cut-off coupling is used instead of the rigid coupling shown in the cuts. This enables the line-shaft to be disconnected from the head-shaft without stopping the prime mover, which is often of much importance in case of accident or minor repairs, especially in the double arrangement shown in Fig. 17.

Receiving and transmitting pulleys should be placed as close to the bearings as possible, framing short "headers" between the main tie-beams for this purpose when necessary. If this cannot be done conveniently the span between bearings may be increased and the size of shaft enlarged according to Table III.

The transverse or bending strain on a shaft may some-

TABLE V. (Cold-Rolled Shafting). Limiting distance between bearings. Torsional strain only. No bending strain except from own weight.

DIAM. OF SHAFT	DISTANCE BETWEEN BEARINGS	DIAM. OF SHAFT	DISTANCE BETWEEN BEARINGS	DIAM. OF SHAFT	DISTANCE BETWEEN BEARINGS	DIAM. OF SHAFT	DISTANCE BETWEEN BEARINGS
1 1/2	7.5	2 1/8	10.2	3 1/4	12.6	4 3/4	15.1
1 3/4	7.9	2 1/2	10.6	3 3/8	13.	4 1/2	15.7
1 5/8	8.4	2 3/8	11.	3 1/2	13.3	4 1/4	16.3
1 7/8	8.7	2 3/4	11.3	3 3/8	13.6	5	16.8
2	9.1	2 3/4	11.6	3 1/2	13.9		
2 1/8	9.5	3	12.	3 3/8	14.2		
2 1/4	9.9	3 1/8	12.3	4	14.5		

COUPLINGS.

In line shafting the coupling of the lengths together is a matter of much importance, as all errors of alignment are likely to increase the friction at the bearings, and, if sufficiently pronounced, to fracture the shaft under continued operation.

The strength of the coupling should equal that of the shaft so far as resistance to torsion is concerned. If solid pulleys are to be used at any point the coupling should be one that is easily disconnected. With split pulleys, which are now widely used, this requirement is not necessary and the shafting may be coupled up permanently by means of rigid couplings, which tend to maintain an accurate alignment under continuous use.

A typical flange or plate coupling is shown in Fig. 20. This is made in medium and heavy patterns, according to the service required. In textile mills, where the load is more nearly uniform, the stresses in the couplings are not so great as where heavy loads are thrown on suddenly, as in rolling mills.

With the coupling shown in Fig. 20 the end of the shafts to be joined are keyed to the flanges, which are accurately bored and faced in a lathe, and then bolted together.

An important requirement in the design of any coupling

is the absence of projections which may catch in the clothing of anyone coming near them. The bolts in the coupling shown are protected by lips or extensions at the outer edge of the flanges. In some makes of couplings of this type the flanges are recessed in order to secure more accurate alignment when erected.

When shafting for a considerable piece of work is made up at the shop the flanges are forced on by hydraulic

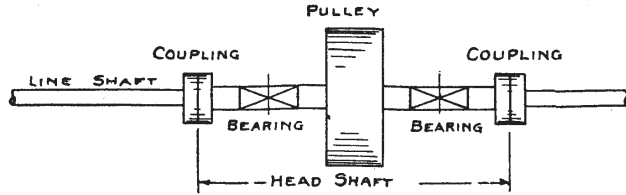

FIG. 17.

pressure, after which they are refaced, thus ensuring more perfect results.

Forged flanged couplings are made by upsetting the ends of the shafts to be joined, so as to form discs or flanges of the proper size, which are turned up in line with the axis

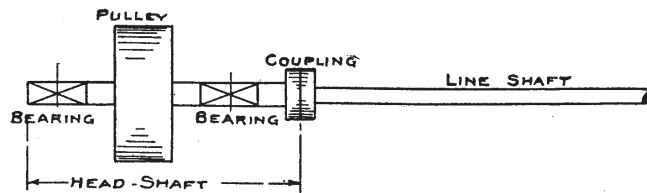

FIG. 18.

of the shaft in a lathe and bolted together like those shown in Fig. 20.

A side-clamp coupling for medium duty is shown in Fig. 21. This is made in halves, with recesses for the bolts which clamp the coupling around the shaft. It is about four diameters in length and can be removed without disturbing the shaft. Couplings of this form are sometimes pro-

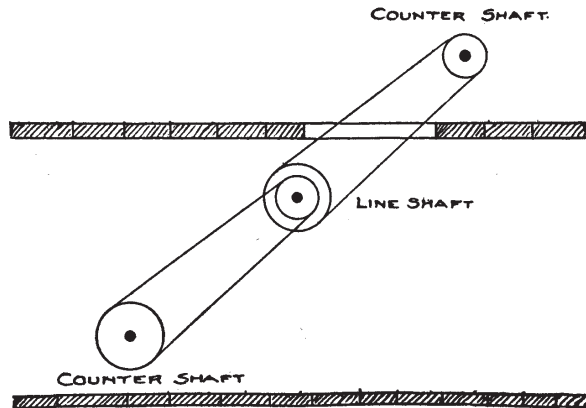

FIG. 19.

vided with a smooth outer casing which completely covers the bolt heads.

The double cone coupling, adapted to medium loads, and

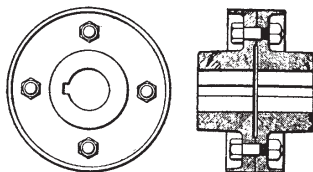

FIG. 20.

shown in Fig. 22, is somewhat more complicated than those previously shown, but has the advantage of being easily removable and allows for some variation in the diameter of the shafts upon which it is placed.

This coupling consists of an outer sleeve finished to receive two cone bushings bored to the diameter of the shaft and drawn together by three bolts, as shown. The effect of this is to clamp the ends of the shafts to the sleeve by means of the bushings. As a precaution against slipping, and to provide additional strength, a key is run the entire length.

An internal clamp coupling is shown in Fig. 23. This consists of a single casting, combining an inner clamp with an outer casing, between which are inserted lengthwise, taper screws bearing the entire length. The clamps are

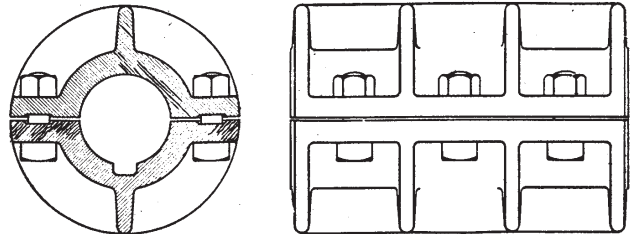

FIG. 21.

divided across the centre of the coupling as indicated, thus making the grip upon the ends of the two shafts independent. This type of coupling is light, simple in construction

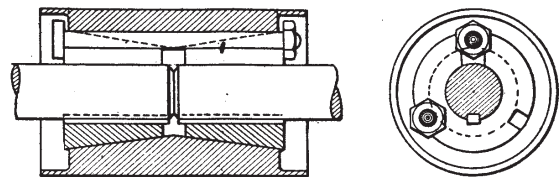

FIG. 22.

and easily removed, and like the one previously described, is provided with a key to prevent any possibility of the shaft slipping in the clamp.

FOREIGN LANGUAGE STUDY.

The realization that Germany's success in capturing foreign trade has been due in large measure to the ability of her commercial travellers to speak, write and read foreign languages, led to a movement in England, beginning in 1915, to train Englishmen in the same accomplishment. The "Textile Mercury" gives the following account of a plan of the Bradford Dyers' Association to help the work along:

The Bradford Dyers' Association are now offering a further number of scholarships for Spanish, Portuguese and Arabic. The number is not yet definitely settled, and from ten it may be increased to fifteen, which it is proposed to divide into, say, eight, Spanish, four Arabic, and three Portuguese. The scholarships are open to anyone between 18 and 30 who is prepared to enter the textile trade, and a technical knowledge of the trade is not an essential condition of eligibility. Preference will be given to those who have served in the forces.

The scholarships will include a year's free study and travel, and at the end of the course the students will be under no obligation to the B. D. A., apart from the fact that the students must associate themselves with some branch of the industry. It is the intention of the directors to send those selected for the Spanish course to Madrid, and while there they will be admitted for a short period to the University of Spain. Those taking Arabic will, prior to their travel to Egypt or North Africa, be required to attend a course in the language at the London University. All expenses incidental to the courses and travel and living will be defrayed.

If this first venture proves the success it is hoped, it is proposed to run similar courses for the next four or five years. Already 350 applications have been received, and the task of selection is going on apace. In making the selections, the committee are being guided not by education of technical knowledge, but rather by personality, and should the scheme produce the results anticipated by its sponsors, the textile trade will be represented abroad in the course of the next few years by men of our own nationality conversant with the native languages and with a knowledge of the special requirements of native trade.

Practical Fixing of Cotton Looms

By John Reynolds

LINING UP 2-1 BOXES.

Lining up consists in placing both boxes on a line with the race plate of the loom. Start from the first or top box. Get this box on a line with the race plate by turning the adjusting nuts C, Fig. 98. A steel straight edge will be found useful for this work. When the first box has been lined up, push in the sliding tooth O, Fig. 98, and turn the loom over so that the second box will rise. Now test the second box to see if it lines up with the race plate of the loom. If this box should be $\frac{1}{4}$ in. too high the stud K, Fig. 98, is too far out from the center of the box-crank L. To remedy this fault loosen the stud K and move it towards the center of the crank L, but be sure to move it so that the boxes will move only one-eighth or one-half of the distance in excess of that required. Then bring the first box in position again

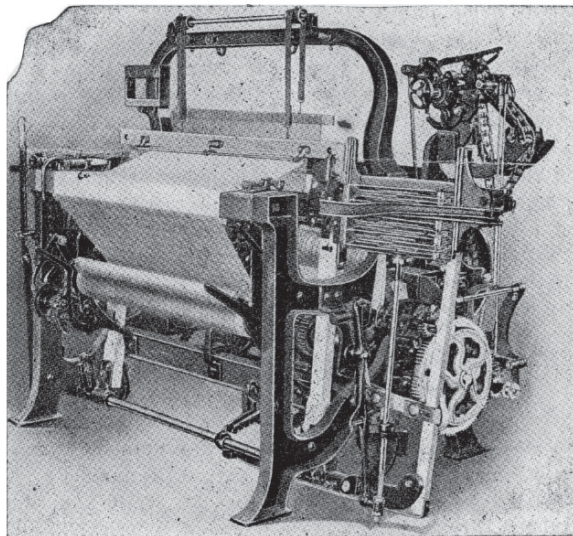

FIG. 101.—A 4 AND 1 BOX GINGHAM LOOM.

and line this box with the race plate. Regardless of the distance that the box moves, whether too much or too little, take only half of this distance by the stud K on the box crank L. Be sure to come back again to the first box and get the other half from the adjustments on the bottom of the box-rod.

If it is found, when coming from a level first box to the second, that the second box is about $\frac{1}{8}$ in. too high or too low, get the adjustments from the stud F on the forward end of the box lever. Moving this stud out will give more throw to the boxes; moving it in will give less. This slot is used to get a rise or fall of only $\frac{1}{16}$ in. to $\frac{1}{8}$ in. Under no circumstances should the stud I be moved after it has once been centered with the center of box crank. It is bad practice to get this stud off of the center.

TIMING THE BOXES.

The boxes must not begin to move until the loom crank has passed the bottom center. The movement must be completed before the crank reaches the top center. They must be level and at rest when the pick is to be delivered.

One method of timing the boxes is as follows: With the loom crank on the bottom center push in the sliding tooth O and move the segment gear Q until the first tooth is fully engaged with the projection or knuckle of the sliding tooth. Tighten up the segment gear, otherwise the weight of the boxes will cause it to slip. The only objection to this method of timing is that no two fixers will set the loom crank in the

same position for the bottom center, and the distance of one tooth is the difference between right and wrong timing.

A method practiced by experienced loom fixers is to take the shuttle out of the box and draw the lay of the loom forward until the dagger strikes the bunter. With the loom crank in this position the boxes should be raised or lowered a full $\frac{1}{8}$ in. This is easily determined by watching the back lip of the box where it runs parallel with the lower edge of the picker slot. This is almost a standard setting with box-loom builders. Many of the later types of box looms are built with the segment gear Q keyed on the bottom shaft with the timing as described here.

ADJUSTING THE RELEASE MOTION.

A release motion is intended to guard against breakage. If the shuttle is half in and half out of the box when the boxes are changing, it is obvious that something would have to break if some means were not employed to prevent it, hence the use of a release motion, which works well if adjusted correctly. The spring E must be strong enough to keep the two parts of the motion together when working

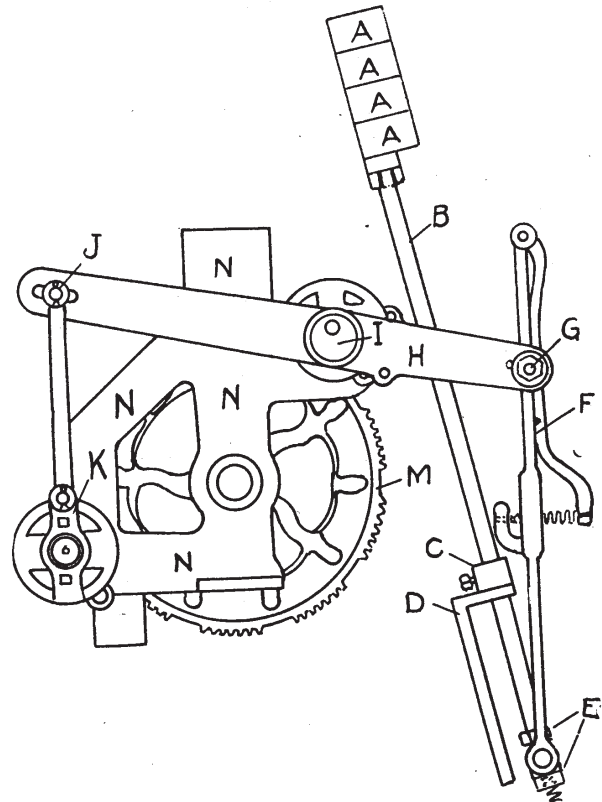

FIG. 102.—BOX LIFTING MECHANISM.

under normal conditions, but must open up when the shuttle gets fast. Sometimes the shuttle will be so tightly bound in the box and in contact with the picker than when the boxes are changing the pressure will be too great, and the release motion will be forced open.

Some fixers remedy this condition by putting two springs on the release motion. This will effect a cure in one way, but on account of the additional pressure the teeth and the knuckle of the sliding tooth O will wear out very quickly. By the exercise of care this can be avoided. Place the shuttle half in and half out of the box. Have the sliding tooth fully engaged. Move the loom by hand and it is then easy to determine the amount of pressure required to open the release

motion. Too much pressure is liable to break the teeth on the segments or break the end of the box lever G. Too little pressure leaves the boxes with a weak foundation. There is no hard and fast rule governing the strength of the spring. This is a matter of judgment.

Pickers play an important part in the running of a box loom. Pickers should never be bought from stock or without regard to the looms on which they are to be used. The manufacturer of pickers usually measures the loom parts in order to get the proper fit. A new picker should need no trimming. A rawhide picker should make its own hole. Pickers not in use should never be allowed to dry out. They should be kept in a bath of linseed oil. The wooden plug should not be taken out except when the picker is about to be used. After running a few weeks the picker will gather dirt and lint which clogs up the passage. Do not use a file to take out the dirt. A half-inch twist drill will clean out the picker, leaving a smooth passage. Pickers should be oiled by the weaver at least twice a day.

When a new bracket is put on the loom it often fits so as to bring too near to the boxes the end of the spindle at the end of the lay. This is a dangerous condition, because it causes a tendency to throw the shuttle out towards the weaver. If there is any variation the spindle should be a little farther from the boxes at the beginning of the pick than at the finish. This will cause a tendency to push the shuttle towards the reed.

All adjustments must be made when the shuttle is on the box or dobbie side of loom. This should not be forgotten. Otherwise many bad warp breaks will be made.

4 AND 1 BOX MOTION.

The fixer who has paid strict attention to the explanation of the 2 and 1 motions will have little difficulty in handling the 4 and 1 box motion. The same methods are employed in leveling the boxes, adjusting the picker and picker spindle, timing the boxes and fixing the release motion. The only difference is in the timing of the boxes and operating the boxes for the different patterns. What is termed "boxing" the colors requires some judgment. The main point is to avoid skip boxes; that is, jumping from box 1 to box 4 or from box 4 to box 1, or even from box 1 to box 3 and the reverse. While the box motion is built to skip boxes, it is good practice to avoid them because the easier and shorter the lifts or drops, the longer the motion will run without fixing. There are times when skip boxes cannot be avoided. If the boxes are set to skip unnecessarily, the fixer, weaver and manufacturer suffer from the consequences.

Fig. 101 shows a 4 and 1 gingham loom of the ordinary type. This 4 and 1 box loom is frequently equipped with a head motion, as shown in the upper right-hand corner of Fig. 101. This loom is of very solid construction and gives little trouble to the fixer.

Fig. 102 shows the box lifting mechanism and illustrates the directions for lining up the boxes, which is really the only difficult operation in fixing this loom. AA are the boxes; B, box rod; C, check collar; D, rod guide bolted to the rocker shaft; E, adjusting nuts; F, release motion; G, adjusting slot in box lever; H, box lever; I, eccentric; J, rear slot in box lever; K, box crank adjuster; L, box crank; M, star wheel; N, frame holding the entire motion.

Particular attention must be given the eccentric I, the box crank adjuster K and box crank L.

Acid Tank for Transport. British Dyes, Ltd. An improved tank to replace the carboy for transporting acids. It is made of steel lined with ebonite. Baffle plates prevent swinging and splashing.

"STRAIGHT LINE" TEXTILE CALCULATIONS.

BY SAMUEL S. DALE.

SIZE OF RUBBER THREAD.

The number or count of square rubber thread, such as is used in elastic fabrics, indicates the number of threads in one inch when laid side by side. Thus a No. 36 rubber thread is 1/36-inch square.

The size is sometimes indicated by the number of yards per pound. The yards per pound vary in *inverse* proportion to the area of a cross section of the thread. For example, the length of one pound of No. 20 rubber thread, with a sectional area of 1/400 square inch, is one-quarter of the length of one pound of No. 40 rubber thread, with a sectional area of 1/1600 square inch or one-quarter of the area of the No. 20 thread.

As the count indicates the actual dimension of one side of the thread in fraction of an inch, the square of the count varies in *inverse* proportion to the sectional area. Thus a 20s thread has an area of 1/400 sq. in.; a 40s, 1/1600 sq. in., the areas being in *inverse* proportion to 400, the square of 20, and 1600, the square of 40.

It follows from the above that the yards per pound are in *direct* proportion to the square of the count. For example, 40s (square 1600) rubber will have four times as many yards per pound as 20s (square 400).

The specific gravity of vulcanized rubber as found in rubber thread varies with the amount and kind of material mixed with the rubber in the process of manufacture. The best authorities give the specific gravity as .925. At this density a cubic foot of rubber weighs 925 ounces. No. 1 rubber thread is 1 inch square and at a specific gravity of .925 the number of yards per pound is found as follows:

$$1728 \text{ cu. in. rubber} = 925 \text{ ozs.}$$

$$1 \text{ yd. No. 1 rubber (36 cu. in.)} = 19.2 \text{ ozs.}$$

$$16 \text{ (ozs.)} \div 19.2 = 5/6 \text{ yd. No. 1 thread per lb.}$$

The length in yards per pound for any number of rubber thread is found by multiplying the square of the number by 5/6.

Ex. Find lengths per pound of No. 20, 30, 40 and 50 and 60s rubber thread.

$$400 \times 5/6 = 333 \text{ yds. 20s per lb.}$$

$$900 \times 5/6 = 750 \text{ yds. 30s per lb.}$$

$$1600 \times 5/6 = 1333 \text{ yds. 40s per lb.}$$

$$2500 \times 5/6 = 2083 \text{ yds. 50s per lb.}$$

$$3600 \times 5/6 = 3000 \text{ yds. 60s per lb.}$$

The number of rubber thread is calculated from the yards per pound by reversing the above operation, multiplying by 1 1/5 being equivalent to dividing by 5/6.

Ex. Find number of rubber thread measuring 750 yards per pound.

$$750 \times 1 1/5 = 900.$$

$$\text{Square root of } 900 = 30, \text{ number of rubber thread.}$$

The size of rubber thread is also determined by a gauge, similar to that used for wire. Owing, however, to the compressibility of rubber, it is difficult to determine the size accurately in this way.

The method of calculating the size from the length and weight is more reliable, but in using it in cloth analysis allowance must be made for the reduction of the size by stretch and absorption, when determining the original size of the thread. The tension under which the thread is held in an elastic fabric reduces the size by destroying some of the power of contraction. There is also a diminution of size by reason of the absorption of the rubber by the surrounding textile materials; this varies with the amount and kind of impurities used in the manufacture of the thread.

No general rule can be given for change of size from either of these causes.

Boiling-Off Silk

By J. L. Girard, Chemical Engineer

HANDLING PIECES IN LOOPS.

This method of handling silk piece goods is extensively used for a large number of light fabrics, mousseline, pongee, crepe-de-chine, etc. The piece is hung on loops or rings of cotton thread which are sewed at regular intervals on one or both selvages. These rings of cotton thread are then hung on sticks, and the piece takes the position shown at Fig. 1. B B show the sticks in cross section; F, the loops or rings of cotton thread; P, the folds of the piece. This illustration shows the piece hung by both selvages, there being a ring or loop of cotton thread around each end of the stick, corresponding to the two selvages, which are thus

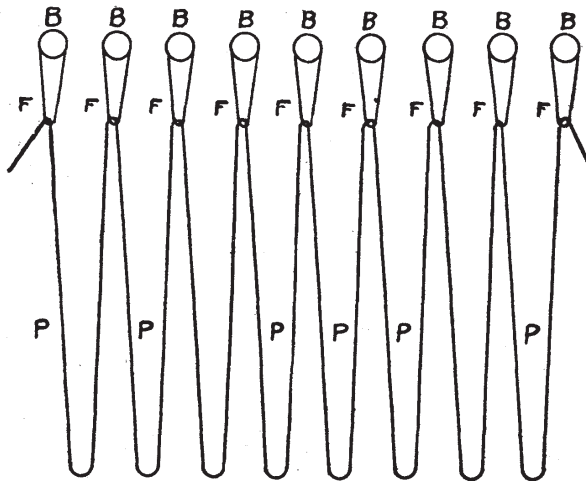

FIG. 1.—DYEING PIECES IN LOOPS.

suspended vertically in the bath. When the sticks rest on the sides of the tub the piece can be readily immersed completely in the liquor, and by moving the sticks so as alternately to separate and bring them together, the folds of the cloth are alternately separated and brought together, which facilitates the action of the liquor on both sides of the cloth.

The other method of looping the pieces consists in at-

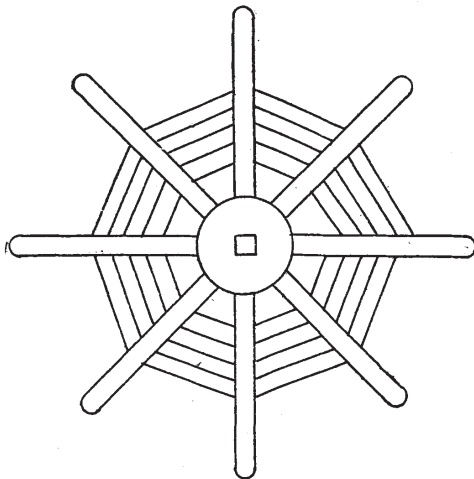

FIG. 2.—STAR FOR DYEING PIECE GOODS.

taching the rings or loops of cotton thread to one selvage only, sometimes passing the loop of thread through several folds of the piece at one time. If the loops are then hung on the sticks the piece assumes a position at a right angle to that shown at Fig. 1, one selvage being looped horizontally at the top of the tub, the other, which is not looped,

being at the bottom. The manipulation of the pieces in the bath is the same, being similar to the handling of skeins, except that it is not necessary to move the pieces from the top to the bottom as they are completely immersed in the liquor.

Larger tubs are required for handling the pieces in loop form than for skein dyeing, or piece dyeing in rope form. The dimensions of the tubs are made to suit the width of the goods. The details of the boiling-off process are naturally identical with those already described.

HANDLING PIECES IN THE OPEN WIDTH.

This method of handling the pieces, which is accomplished mechanically in a number of different ways, consists in keeping the piece spread out during the operation, preventing the possibility of its forming folds. It is used for both heavy and light goods in which folds are liable to form, and cause streaks that show after drying. It is also employed for fabrics in which the boiling-off bath causes a contraction or shrinkage of the yarn, for example, certain fabrics made of mixed wool and silk. In the last named case the piece is kept under tension on rolls to counteract the shrinkage as much as possible, this arrangement being known as boiling-off under tension.

For heavy and delicate fabrics, *gros satin*, for example, there is still used a very old arrangement formerly employed in blue-vat dyeing, and which is known as the *champagne*

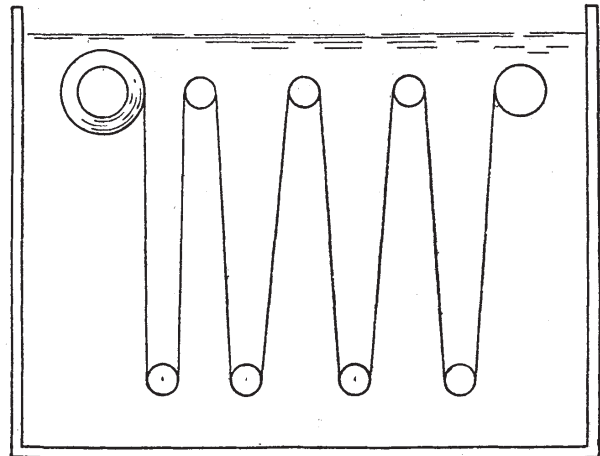

FIG. 3.—DYEING SILK PIECES UNDER TENSION.

or star. This arrangement consists of a vertical stem or shaft, on which are placed two hubs each carrying a set of horizontal spokes arranged in the form of a star, as shown in the plan, Fig. 2. These spokes each carry a row of hooks on the inside. The selvages are fastened to these hooks, and the piece is thus wound in spiral form between the two stars, as shown in the illustration.

The production with this device is small, and it requires a very large bath, but a perfect circulation of the liquor between the folds can be produced by moving vertically the *champagne* or reel, which is simply hung in the soap bath. No matter how delicate the goods are there is no danger of their becoming marked, as the pieces do not come in contact with any solid part of the device. With this arrangement the pieces are given the two soap baths, degumming and boiling-off, rinsing and weighing baths, etc. The cloth is removed only when all of the operations are completed.

(Continued on page 36)

The Lighting of Textile Mills

By Neville S. Dickinson, Electrical Engineer

PRISMATIC GLASS REFLECTORS.

Prismatic glass reflectors are also very efficient. They are not opaque, but allow a small amount of light to pass through the glass to the ceiling which adds somewhat to the cheerfulness of a mill. These reflectors control the light distribution very closely. Observe the difference in distribution obtained from the reflectors illustrated by Figs. 21 and 22. Fig. 24 represents the light distribution produced by the reflector shown at Fig. 22; Fig. 25, the light distribution obtained from the reflector shown at Fig. 21.

Reflectors are manufactured for all sizes of lamps and in several shapes. The variation in shape or contour is for the purpose of light control, that is, to supply reflectors that will produce an even illumination on the working plane for various ratios of lamp spacing to mounting height. For example, Fig. 21 is an "intensive" type and suited for spacings $1\frac{1}{2}$ times the mounting height, while Fig. 22 illustrates the "extensive" type, which gives an even illumination when

sizes together. The dome and bowl shapes, shown at Fig. 26, are widely used for mill lighting. The bowl reflector is suited for spacings not exceeding $1\frac{2}{3}$ times the suspension height above the working plane. It gives a low angle of cut-off and so shields the eye from the direct rays of the lamp.

The dome reflector gives a slightly wider distribution. The lamp filament cannot be so well shielded and is therefore not so desirable a type of reflector. Bowl-frosted lamps should be used with it. In fact, bowl-frosted lamps should be used with all types of reflectors unless the mounting height is exceptionally high.

The new RLM standard dome reflector represents a very desirable type of reflector. It has only recently been placed on the market. It has a low angle of cut-off and to obtain uniform illumination the spacing should be about equal to the mounting height. Bowl-frosted lamps should be used with this reflector.

The efficiency of porcelain-enameled steel reflectors depends upon the quality of the enamel. It should be smooth and white, otherwise the absorption will be high.

Compared with the glass reflectors, steel reflectors are naturally much more rugged and there are many places

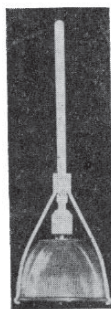
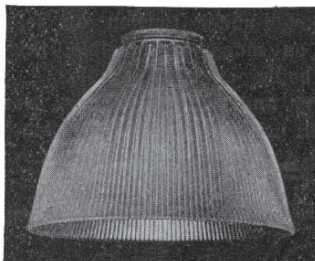
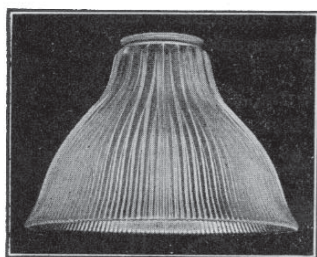

FIG. 21.

FIG. 22.

FIG. 23.

the spacing is equal to the mounting height, say 10-foot centers and 10 or 12-foot mounting height.

Fig. 23 shows a prismatic reflector which has an adjustable holder, which by a slight change in the position of the reflector may be used for several sizes of lamps. The type illustrated is suited for lamp spacings from $1\frac{1}{2}$ to $1\frac{3}{4}$ times the mounting height above the working plane.

It should be observed that the reflectors so far illustrated have had a low angle of cut-off; that is, the reflector is of such a shape and the lamp filament is so placed with respect

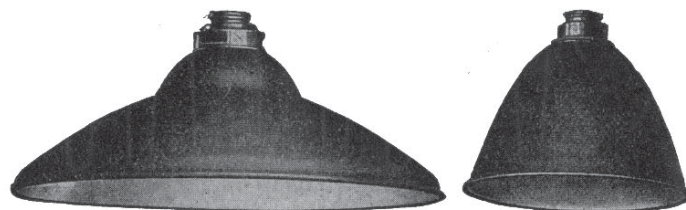

FIG. 26.

where it would not be wise to install the former. Glass reflectors are stronger than is generally supposed and both types, mirrored and prismatic glass, are widely used for textile mill lighting.

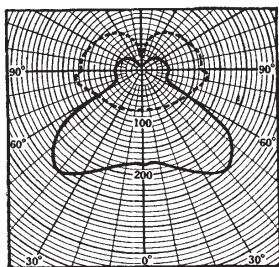

FIG. 24.

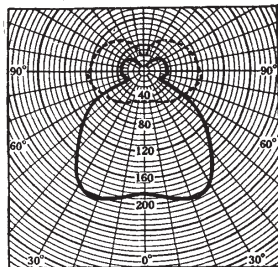

FIG. 25.

to it that when the right size of lamp and reflector are used together no light is transmitted in a direction vertically upward more than 60° , Figs. 24 and 25. This feature eliminates direct glare and is of great importance.

PORCELAIN ENAMELED REFLECTORS.

Porcelain-enameled steel reflectors are less expensive than the glass reflectors. They are less efficient and light distribution cannot be so well controlled with them. With these reflectors, as with the glass reflectors already mentioned, it is necessary to use a lamp and a reflector of the right

CHICAGO SALES OFFICE.

Wm. B. Scaife & Sons Company, of Pittsburgh, announces the opening, on July 1st, of a Chicago sales and engineering office at 38 South Dearborn street, with Charles F. O'Hagan, formerly chief engineer of the company at Pittsburgh, as resident engineer and manager.

This company is the oldest manufacturing concern west of the Allegheny Mountains. During the more than one hundred years since their business was founded, they have from time to time, as conditions arose, added to their manufacturing facilities. They now manufacture black or galvanized, riveted, brazed or welded steel tanks for air, gas and liquids, steel shipping drums, range boilers, steel structures, also the well-known We-Fu-Go and Scaife water softeners and filtering equipment.

WALES REPRESENTATIVE TO VISIT ENGLAND.

T. J. L. Crane, of the Wales Advertising Co., 110 West 40th street, New York, will sail for England on July 1. He will remain abroad for some time in the interest of clients of the Wales agency. Mr. Crane is an Englishman, is familiar with British methods, and has a wide acquaintance in trade circles abroad. He has spent many years in the United States, and is in charge of a number of national campaigns handled by the Wales Advertising Co. During the war he served in the Royal Flying Corps of Canada.

QUESTIONS AND ANSWERS

We invite subscribers to submit any questions they desire answered regarding the manufacture or sale of textile products. Any question sent to us will be answered at once if the information is in our possession. If it is not, we will submit the question to experts and their replies will be published promptly. In urgent cases we will, if practicable, send the inquirer an advance copy of the reply. Inquirers are requested to state their questions as clearly, concisely and fully as possible. This will save time and misunderstanding. The names of inquirers are held in confidence.

CALCULATING CHANGE GEARS FOR LOOMS.

Editor of "Textiles":

The ratchet gear on a plain loom has 80 teeth and the take-up pawl is driven by an eccentric on the cam shaft, which makes one revolution for every two picks. Fastened to the same shaft as the ratchet is a 20-tooth pinion that drives the change gear, the latter being compounded with a 16-tooth which in turn drives a 54-tooth gear on the shaft of the sand roll. If the actual circumference of the sand roll is $13\frac{3}{4}$ and 2 per cent. is allowed for contraction of the cloth after it is taken from the loom, what is the constant of the take-up motion? If a 38-tooth change gear is on the loom how many picks per inch does the cloth contain?

SIBLEY (193).

A good way to calculate the change gear for a required number of picks or the picks resulting from a given change gear is to calculate first the number of picks per tooth of the change gear. In the example stated by "Sibley" this calculation is as follows:

The cam shaft makes one revolution for every two picks. This is equivalent to 160 picks for one revolution of the 80-tooth ratchet gear. With a 100-tooth change gear the number of picks per revolution of the sand roll is:

$$(160 \times 100 \times 54) \div (20 \times 16) = 2700 \text{ picks per rev. of sand roll.}$$

Allowing for contraction of cloth the effective circumference of the sand roll is:

$$13.75 \times .98 = 13.5 \text{ inches. Then: } 2700 \div 13.5 = 200 \text{ picks per inch with 100-tooth change gear, } 200 \div 100 = 2 \text{ picks per inch for each tooth of change gear.}$$

With this constant, picks per tooth of change gear, the change gear for a given number of picks per inch or the number the picks per inch with a given change gear is easily found.

Referring to "Sibley's" example:

$$38 \text{ (change gear)} \times 2 = 76 \text{ picks per inch with 38 change gear.}$$

Find change gear required for 60 picks per inch.

$$60 \div 2 = 30\text{-tooth change gear for 60 picks per inch.}$$

If, as in the example given by "Sibley," the change-gear is a driven gear, the number of picks per inch increases with the number of teeth in the change-gear and, consequently, the number of teeth is multiplied by the constant in order to determine the picks.

If the change-gear is a driver the number of picks decreases as the number of teeth in the gear increases, and the constant is divided by the number of teeth in order to determine the picks.

ANALYZING CLOTH.

Editor of "Textiles":

Please explain the method of analyzing a small sample of cloth to find how it is made, including number of ends and picks per inch, weight per yard, yards per pound, size of yarn and percentage of cotton and wool.

OHIO (98)

The best method of analyzing is that known under the name of "straight line" analysis. The "straight line" die has an area of 1-300th square yard (4.32 sq. in.) and may be of any desired form, a rectangle 1.8x2.4 in. being usually the most convenient. It is used in connection with the "straight line" system of analyzing cloth to determine the weight per yard, yards per pound, size of the yarn and threads per inch in a given sample of cloth.

If a cutting die is not available the sample can be cut with shears or a knife around a piece of tin or

cardboard of the required size. In addition to the cutting die or template, an ordinary grain scale accurate to 1-10 grain, and a large needle for raveling the cloth are required. The number of threads per inch is found by cutting the threads projecting on each side of the sample and dividing the total number thus found by the length in inches of the respective side.

If it is desired to "boil out" mixed fabrics to determine the percentage of vegetable and animal fibers, an alcohol lamp, a small cup and a supply of caustic potash or caustic soda are required. The wool is dissolved by boiling in a solution of the caustic ($\frac{1}{4}$ oz. caustic to $\frac{1}{2}$ pint water) for fifteen minutes. The difference between the weight before and after boiling and drying is the weight of the animal fiber. The undissolved material is the vegetable fiber, the weight of which is usually increased 5 per cent. to allow for a shrinkage in weight by boiling. The sample to be boiled should be sewed up in a small sack of cotton cloth to prevent loss of the residue. This vegetable residue should be dried by exposure to the air at the ordinary temperature in order to retain the normal amount of moisture. The sample boiled out can be of any convenient size and need not be measured.

The formulas for making the calculations are given below. The weight per yard and yards per pound can be found by formulas j, k, l, m, n, o, p, q and r.

(a) Average cotton yarn number = threads per inch + grains per 1/300th sq. yd.

The cotton yarn number of any particular group of threads can be determined by the same method after counting and weighing separately.

(b) Average cotton yarn number = (threads per in. \times sq. yds. per lb.) \div 23 1/3.

(c) Average cotton yarn number = (threads per inch \times 24) \div (ozs. per sq. yd. \times 35).

(d) Woolen runs = cotton yarn number \times .52 1/2.

(e) Worsted yarn number = cotton yarn number \times 1 1/2

(f) Linen lea or woolen cut = cotton yarn number \times 2.8.

The spun yarn number is calculated for cotton, woolen, worsted and linen from the finished yarn number by allowing for changes that may have occurred in length and weight. In the following formulas these changes are expressed by the yield of finished cloth in percentage. Thus, if the spun yarn shrinks 10 per cent. in length or weight in weaving and finishing, the yield of finished cloth is 90 per cent.

(g) Spun yarn number = finished yarn number \div yield % in length.

(h) Spun yarn number = finished yarn number \times yield % in weight.

(i) Spun yarn number = (finished yarn number \times yield in weight) \div yield % in length.

(j) Ounces per running yard 52 1/2 in. wide = grains per 1/300th sq. yd. no calculation being necessary.

(k) Ounces per running yard = (grains per 1/300th sq. yd. \times width in inches) \div 52 1/2.

(l) Ounces per square yard = (grains per 1/300th sq. yd. \times 36) \div 52 1/2.

(m) Ounces per square yard = (grains per 1/300th sq. yd. \times 300) \div 437 1/2.

(Continued on page 32)

Knitting Department

THE MANUFACTURE OF KNIT GOODS.

BY JOHN CHAMBERLAIN

FASHIONING COURSE.

In the manufacture of fashioned hosiery the fashioning is always effected by narrowing, as the hose is begun at the top of the leg for the legging, and at the wide part of the foot on the footing frame. The actual narrowing course is timed by one of a system of ratchet-wheels and pawls, by means of which the fashioning is repeated after a given number of courses in accordance with the shape desired. The camshaft is moved endways so that a second set of cams control the movements of the needle bar and catch bar, and other cams are brought into action to give the movements to the narrowing mechanism and to rack the screw-boxes.

The actual reduction of the width of the fabric is obtained through the agency of the points P, which number six on each selvage. These points have cranked stems, and are carried in tricks in narrowing fingers B, Fig. 11, at 1.

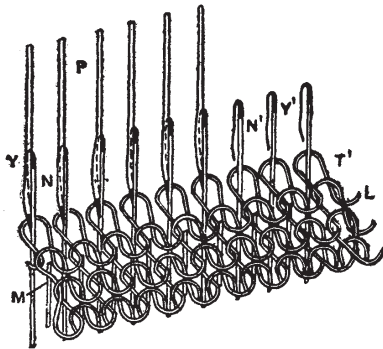

FIG. 12.

All the narrowing fingers for the one selvage are carried on the rod A, and all the fingers for the other selvage on a higher rod not shown. Both rods are moved inwards at the prescribed time usually two needle spaces, but sometimes one, by means of the racking screw-boxes, which also shorten the draw of the carrier rod 28 to a like degree.

The operations are as follows: (1) Removing the six selvage loops on both edges of each division; (2) inward racking of the points whilst the loops are off the needles; (3) delivery of the released loops back to the needles.

The method of removing the selvage loops is shown in Fig. 12. The main camshaft, having been moved endways, presents the fashioning cams to their operating levers, and the point fingers are lowered to the level of the needles.

The needles N are moved towards the points P, so that the beards Y become embedded in the large grooves or eyes in the points, whilst the tips of the points are similarly embedded in the eyes of the needles. At this juncture the needles and points descend as a whole, so that the loops pass first on to the cover of the point, and finally, when the needles descend beyond the level of the knocking-over bits M, on to the stems of the points, clear of the needles. The needles and points are then raised until the points are above the knocking-over bits M the needles being brought laterally away from the points.

The racking of the screw-boxes now takes place, and the points are moved inwards a distance of two needle spaces, so that the released loops are in position for retransfer. The needles again move towards the points, and the cover is once more effected, while both parts are between the knock-

ing-over bits M. The position is then as shown in Fig. 13. The sinkers and dividers are brought forward to hold down the loops, and the points and needles make a co-ordinated upward movement, so that the loops, retained by the sinkers, pass back on to the needles. Finally, the points rise rapidly away from the still rising needles, the camshaft is moved back so that the knitting-course cams are presented, and the knitting is resumed on the reduced width.

OPERATION OF LEGGING FRAME.

The operator of a hose-legging frame has several hand manipulations to make during the knitting of a set of legs. To commence, the indicators must be set at the correct numbers to ensure knitting on the right width. As the numbers denote the number of leads narrowed, it is evident that 9 represents the maximum width on each side, so that if a frame will knit on a width of 120 leads, and the required size is 110 leads then the screw-boxes must be racked inwards to 5 on each side. Hence the position of indicators for central knitting should be: Total leads—leads in width of leg \div 2.

Having adjusted the width, the operator depresses the slack course lever with his foot and puts in the welt bars, catches the sinker loops of this course, hooks the drawing-off bands on to the welt bars, and attaches the weight. Two inches or more are knitted and the frame is stopped, needle bars brought out one notch, welt rods put in, welts turned over, weight attached, and welt bar removed. Knitting is

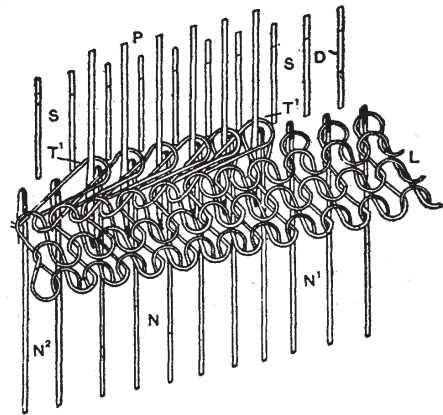

FIG. 13.

recommended, and continued straight for the leg portion of the hose to the length desired.

At this juncture the operator puts the screw-box clawers and the timing-wheel pawl into action, so that the narrowing for the calf occurs at the correct intervals. As the narrowing continues, the operator must again observe the position of the indicators on the screw-boxes, so as to throw out the timing wheel pawl when the correct number of narrowings have been put in.

Straight knitting is continued for the ankle, splicing carriers put in for high-splicing the heel parts, and lengths measured at intervals, so that the frame can be stopped for the purpose of introducing the divisional carrier guides for the heel and instep parts. To do this the operator unlocks the heeling carriers, puts on the friction, readjusts the stops on the screw-boxes, so that the heeling carrier rods are dependent upon the racking of the screw-boxes on the outer selvages, lifts up the central stops for limiting the draw of

the legging carrier rod, and the knitting is now continued in three separate selvaged portions.

Just before the finish of the divisional knitting the operator throws in the timing-wheel pawl and shapes the heel parts by putting in a few narrowings, makes a slack course for linking, and presses off the heel parts, changes all stops and rods back to their old positions, and racks in the screw-boxes, so that the knitting, although continued on the same width in the one division, can be narrowed. Straight fabric is made for the foot or instep portion, narrowings put in for the toe, slack course for linking, and the blank is pressed off, and the whole of the operations repeated for the next set.

THE FOOTING FRAME.

The legging blanks are linked at the heel parts, which operation will be described later, and the inner parts of the heel sections put on to transferring points, so that the footing frame may receive the work quickly by a simple transferring movement from points to the needles, instead of the machine being idle while the selvage loops are put direct onto the needles. The operator transfers the blank to the needles puts in action the timing-pawl and racking clawker for the gusset narrowings, throws out the pawl for the straight knitting, introduces the correct pawl for toe narrowings, and finally makes a slack course and presses off. Assistants are required for keeping the frame supplied with the legging blanks, as the operator is unable to cope with the putting on of the selvage heel loops in the short time that the machine is making the foot.—*Textile Manufacturer, Manchester, Eng.*)

ATTACHMENT FOR HOSIERY MACHINE.

The object of this device, recently patented is to facilitate knitting upon transferred fabric sections, making more certain the automatic beginning of the knitting on the second machine. This is accomplished by an arrangement which takes up the slack of the yarn left from the previous knitting operation and which is to be fed to the needles for the new knitting operation.

Fig. 1

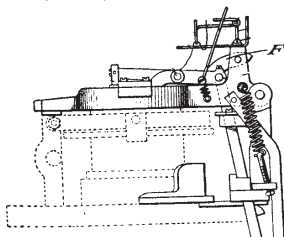

Fig. 2

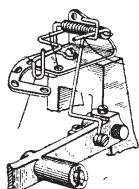
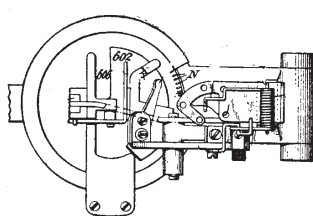

Fig. 3

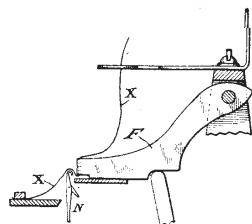

Fig. 4

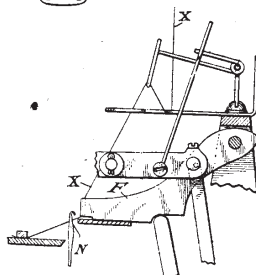

Fig. 5

Fig. 1 shows a knitting head with attachment applied; Fig. 2, a plan view; Fig. 3, a perspective of the device; Fig. 4, skeleton views showing how the device insures the feed of the yarn to the needles at the beginning of a new operation.

The yarn on its way to the yarn guide F is passed through an eye or eyes in a fixed yarn guide plate and in connection with this fixed yarn guide is provided the new attachment acting to take up the slack of the yarn as left from a preceding knitting operation.

This take-up attachment may conveniently be made of wire as shown and comprises a standard secured by a screw or otherwise to a plate, and affording a horizontal pivot for a coiled wire lever. This lever has at one end a thread-guiding arm, and at the other end an arm which is adapted to be acted on by a bent wire finger. When this finger is raised the thread guiding arm will be raised to take up the slack of the thread.

When a knitting operation is terminated as by the completion of a half-hose, the yarn guide F is lifted away from the needles by its thrust bar, the yarn is severed by the cutter and the end is clamped automatically under the clamp. When at the beginning of the next knitting on this machine, as in the case where a ribbed cuff has been transferred to the needles, and the latch ring with its parts is lowered to its normal horizontal position, and the yarn guide F is dropped to the yarn-feeding position shown in Fig. 4, there will be more or less slack in the yarn. That slack is liable to be such that the yarn will curl over the needle tops as indicated in Fig. 4 and consequently the needles will fail to take the yarn. By providing the take-up devices and actuating them at the moment when the appropriate needles are to take the yarn for the new knitting operation, the yarn X is drawn into the path of the needles, which then proceed with the knitting.

WEIGHTS AND MEASURES IN CANADA.

At the annual meeting of the Canadian Manufacturers' Association at Toronto, on June 12, the following resolution was unanimously and enthusiastically adopted:

BE IT RESOLVED that the Canadian Manufacturers' Association, in annual meeting assembled in Toronto, on June 12th, 1919, endorse the following resolution which was passed by the National Association of Manufacturers of the United States at their annual meeting held on May 20th, 1919, in New York:

"WHEREAS national legislation is proposed and is being vigorously urged to substitute the Metric System for our present standards of weights and measures,

"AND WHEREAS in the language of the 'British Committee on Commercial and Industrial Policy after the War,' which exhaustively investigated this proposal,

'We are not convinced that the metric system is, upon the whole, even theoretically superior to the British system, and we are satisfied that the practical objections to the proposed change are such as to decisively outweigh any advantages which are claimed for it.'

"THEREFORE BE IT RESOLVED that we regard the present period of difficult readjustment from war to peace as a most untimely period in which to discuss or adopt a new system of weights and measures and thus add another to the many trying difficulties of this hour."

WOOLEN AND WORSTED OVERSEERS.

The thirty-seventh semi-annual meeting of the National Association of Woolen and Worsted Overseers was held in the hall of the Philadelphia Commercial Museum on June 7, this being the first meeting of this organization to be held outside of New England. The meeting was called to order by President Robert J. Harrington, and an address of welcome was delivered by Edward J. Cattell, city statistician. The following nominations were made to fill offices at the annual election in the fall: President, P. J. Harney; 1st vice-president, C. A. Williamson; 2nd vice-presidents, P. F. Hanlon, Thos. Parkin; 3rd vice-president, J. A. Daly; treasurer, Thos. Buchan; recording secretary, J. H. Pickford; secretary of the Beneficial Department, Wm. E. Davison; treasurer of the Beneficial Department, Thos. Buchan; trustees, George Wishart, M. J. O'Connell, E. Frederick Deverall.

Secretary J. H. Pickford read a paper on "Twist in Woolen Yarns." The banquet in the evening was well attended, the speakers being W. R. D. Hall of Philadelphia, Dr. Wm. P. Wilson of the Philadelphia Commercial Museum, A. C. Bigelow of the More Sheep, More Wool Association, Miss J. E. Lagerquist of the Textile Review, and F. L. Babcock of Fibre and Fabric, Boston.

Dyeing, Bleaching and Finishing

THE PROCESS OF CARBONIZING.

BY A. GANSWINDT.

The Deru carbonizing machine shown at Figs. 14, 15 and 16 is based on an entirely different principle from that of the machines already described. This machine is the invention of Deru of Verviers, Belgium, where it was perfected in the inventor's wool scouring establishment before being offered to the trade. The Deru machine is specially suited for carbonizing fine wool which it leaves open, soft, elastic and white. It is also used for carbonizing noils. It consists of two series of horizontal racks, on which the wool rests. Each rack is 3' 4" wide and 13' long, and swings

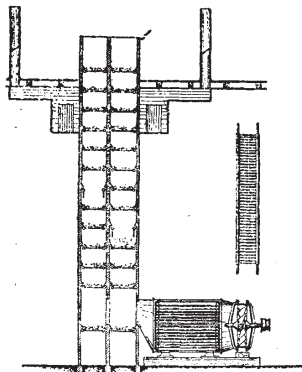

FIG. 14.

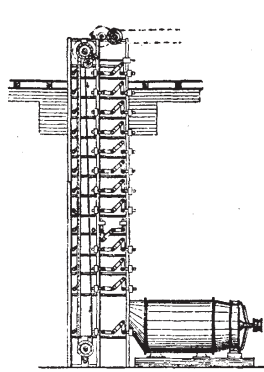

FIG. 15.

downward on hinges from each side, as shown in Fig. 14. A slowly moving, endless belt causes the racks to open successively and the wool to drop to the next rack below, after which the rack closes automatically. The wool is laid on the upper rack by an attendant and is delivered at the bottom of the machine in a dry and carbonized condition.

The duration of the drying process varies with the grade of wool and the temperature from 45 to 60 minutes; carbonizing, from 50 to 70 minutes. The heat is supplied by a steam heater. A fan forces the air through this heater and then upward through the wool in the direction opposite to that in which the wool is moving. After passing through the machine the used air escapes through the chimney. The wired screen at the end of the chimney pre-

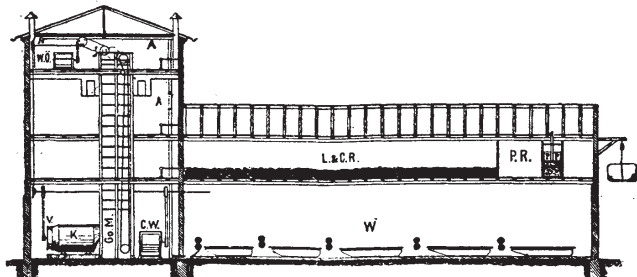

FIG. 16.

vents the escape of particles of wool that may be carried along with the air. The machine is built either single or double, and with a varying number of racks, ordinarily from twelve to fourteen.

As a result of the strong air draft a relatively low temperature and the constant agitation of the wool as it falls from rack to rack, the material is kept open, soft and elastic. The Deru machine requires a relatively small floor space, but is so high that a separate tower is needed for housing it. The wool is blown by an air blast from the scouring

machine to the feed end of the dryer. Usually the carbonized wool is delivered at the ground floor, but can be delivered on the second floor and then passed through a spout to the neutralizing bath in the room below. The different floors of the drying tower can be used for wool sorting and storage. After the scoured wool is extracted either by squeeze rolls or a centrifugal machine it is a good plan to pass it through a small opener in order to deliver the wool in an open condition to the machine. If it is desired to remove all the carbonizing vegetable material, the wool as it leaves the carbonizing machine is passed through a duster provided with crush rolls at the feed end.

A plan of a wool carbonizing plant of this kind is shown at Fig. 16. The first floor W is used for wool scouring. The wool is blown by a fan through the pipe A to the top floor, where it is being passed through the opener W O, and then fed to the machine Co M. K is the air heater; B, the fan; C W, the wool duster. Above the wash room are the storage and conditioning room L and C R, the packing room P R, and the baling press P P.

The production of a double machine with twelve to fourteen shelves is 6,000 to 7,000 pounds of dry wool, or 3,500 to 4,500 pounds of carbonized wool per day. The advantages of the Deru machine have led to the building of a smaller size adapted for small mills and having a production of 1,000 to 1,200 pounds of wool per day. This machine has three or four racks.

OXYGEN IN SODIUM PEROXIDE.

Methods depending on the liberation of hydrogen peroxide by water, followed by titration with potassium permanganate, and on the treatment of sodium peroxide with potassium iodide and potassium bicarbonate and titration of the liberated iodine with sodium arsenite give low results, while measurement of the oxygen liberated by water in the presence of cobalt nitrate gives high results. The following processes yield accurate results:

(1) water (100cc.) is mixed with concentrated sulphuric acid (5cc.) and chemically pure boric acid (5 grms.); sodium peroxide (0.5 gm.) is added gradually to the mixture, which is kept briskly shaken, and the liberated hydrogen peroxide is titrated with potassium permanganate. The low results given by the older permanganate method are to be attributed to the catalytic decomposition of a portion of the hydrogen peroxide by the manganese sulphate formed during the titration. (2) Sodium peroxide is introduced gradually into a solution of potassium iodide (2 grms.) in dilute sulphuric acid (1 in 20; 200cc.); the iodine is titrated with standard sodium thio-sulphate.

The results agree with those obtained by the permanganate method. (3) Sodium peroxide (0.2 to 0.3 gm.) is mixed with about 10cc. of copper sulphate solution (0.05 per cent.) in a small flask connected to a nitrometer; the flask is shaken, and decomposition is completed within a minute, when the liberated oxygen is measured. The gas evolved contains about 0.32 per cent. of carbon dioxide and 0.08 per cent. of hydrogen.

With cobalt nitrate as catalyst, the results are invariably high; the author considers that this may indicate the presence of an oxide higher than the peroxide. The action of the atmosphere on sodium peroxide has also been investigated; moisture appears to be more active than carbon dioxide in causing decomposition.—(The Analyst.)

DYEING VARIEGATED YARN.

The machine shown in the illustrations, for which a patent has recently been granted, is designed to dye parti-colored yarn, such as is used in the manufacture of certain styles of knit goods, giving a variegated appearance to the fabric. Fig. 1 is a side elevation showing the essential parts of the machine; Fig. 2, a perspective view, with parts broken away, of the dye holder and wicks.

The yarn or other material passes over a pin and through a guide eye fastened to a block or nut, which is threaded on a spindle, the yarn being guided up and down the length of the cone.

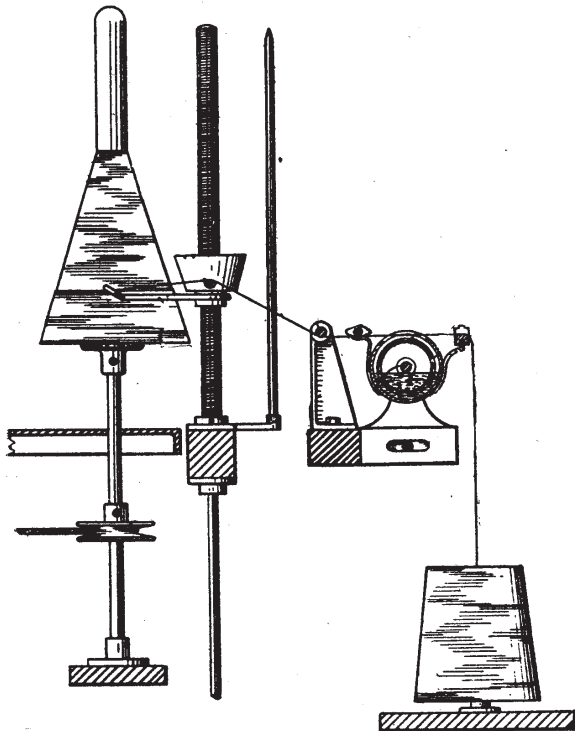

FIG. 1.

A tank is mounted horizontally above a suitable support at a point between the cones, and contains a quantity of liquid dye. A shaft extends lengthwise within the container, on which, at spaced intervals, disks are fixed, around which cylindrical rings or wicks of absorbent material are secured.

The container is slotted at a plurality of spaced apart intervals in its upper side, the wick formed by ring coming

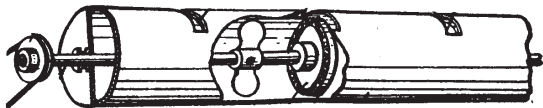

FIG. 2.

at its upper portion above the ends of its associated slot. For each of the wicks a thread of the material wound on the cone passes to a cone. The shaft is continuously operated.

The yarn is carried through any suitable tension device at one side of a slot, and thence directly across the container, through the slot and under a pin which may be mounted on a bracket, thence leading over the pin previously described. Normally the yarn is carried so as to be clear of the wick.

Supports are secured at each end of the container to carry a shaft which parallels the container and under which the yarn passes. At spaced intervals in the length of the shaft cams are fixed, one in alignment with each slot 17, the same

being elongated and of the shape shown in Figs. 3, 4 and 5. with opposed edges, which on rotation of the shaft bear against the yarn and press it into contact engagement with its associated wick. With every revolution of the shaft the material is pressed twice into contact engagement with a wick twice into contact engagement with a wick receiving coloring matter during such contacts and being free of the wick during the momentary period when the cam is in a horizontal position.

STANDARDS FOR DYESTUFFS FOR CHINA.

Practical dye men and Hongkong importers of dyes report that the chief factor in the future of the sale of American dyes in China is the standardization of color shades. One of the chief elements of the success of German dyes in this field was that certain shades popular among the Chinese could be relied upon. The matter of color is very important among the Chinese aside from the comparative beauty. Many of the colors have special significance of a ceremonial sort as well as being regarded more or less lucky or unlucky. There are large interests in China, especially in Amoy, Swatow, Chuchow, and various South China coast cities, where imported shirtings and sheetings are dyed for sale to the Chinese. The basis of this entire business is the quality of color in the cloths thus handled, which depends on the uniformity of color and the quality of the dyes.

It is essential in getting in touch with this trade, which is handled almost entirely through Hongkong, that the exact shades required for the business be ascertained and adhered to in every case. This is an important factor in the general dye trade in China. The Chinese are not hunting new colors or novel shades. They usually prefer high quality standard colors and shades, particularly indigo blue, dark brown, and black, which are the most common colors to be noted in any Chinese assembly.

The introduction of American dyes into the South China field has been much more extensive than has been generally realized, and on the whole their success has been quite marked and generally satisfactory. Some of the colors offered have not been uniform in lasting quality or in shade. The only safe method to follow in the Chinese trade is to secure samples of what is wanted and manufacture to the sample. Dyes made to their specifications as to shade and uniform in quality and at a fair price will find an almost unlimited market. The volume of trade in this field is such as to justify every effort to secure a permanent foothold in it.—(Consular Report.)

IMITATION MOHAIR YARN.

A method of manufacturing imitation mohair yarn, recently patented, is described by the inventor as follows: In the manufacture of an imitation mohair difficulty has always been present in producing a finished yarn which has the luster of real mohair, but which does not feel harsher or softer than the real material. This defect can be remedied by using artificial silk waste which is especially treated, as described below. The silk waste is then mixed in a certain proportion with wool.

In view of the fact that wool is an animal fiber, it is necessary to treat the artificial silk waste so that it may nearly have the feel of real wool. Artificial silk normally contains about 11 per cent. moisture, and by drying the moisture content can be readily reduced below 5½ per cent.

It is then treated with a vegetable oil, such as olive oil, until it has absorbed between 6½ and 7½ per cent. of its weight, so that the moisture contained in the silk waste shall not increase during the subsequent operation of spinning above 5½ per cent.

Vegetable oil is preferred because in the subsequent operation of spinning and particularly dyeing, such oil may be removed from the artificial silk waste more readily than animal or mineral oils can be.

The product obtained from the above described process is then thoroughly mixed with wool in the proportion of 41 per cent. artificial silk waste and 59 per cent. wool.

RECENT TEXTILE PATENTS

- Bobbin-box stand. 1,299,613. A. E. Rhoades, Hopedale, Mass.
- Bobbin-stripper. 1,300,004. B. A. Peterson, Rockford, Ill.
- Carding-engine, Stripping apparatus for. 1,302,012. J. W. Cook, T. E. Leigh, J. Jowett, and N. Cook, Manchester, England.
- Carding-machine. 1,302,109. G. M. Whitin, Whitinsville, Mass.
- Carding-machine. 1,299,105. L. Atherton and O. Meek, Tallassee, Ala.
- Dyeing yarn and the like. 1,299,811. W. A. Ainsworth, Grand Rapids, Mich.
- Dyeing and the like apparatus. 1,298,832. J. J. Tracy, Cleveland, Ohio.
- Dyeing-machine. 1,301,920. H. M. Dudley, Philadelphia, Pa.
- Dyeing stockings or the like, Machine for. 1,301,184. F. Sikora, Philadelphia, Pa.
- Embroidery-machine. 1,300,838. W. Hueller and M. Krapp, Weehawken, N. J.
- Fabric-cutting machine. 1,299,536. J. Appelbaum, Philadelphia, Pa.
- Fabric covering, Machine for affixing. 1,302,288. A. Bianchi and J. Cochipinti, New York City.
- Fabrics, Making. 1,302,195. S. T. Metz, Brooklyn, N. Y.
- Flax and like fiber scutching. 1,302,261. J. Williamson, Portadown, Ireland.
- Garment, Union. 1,301,872. G. W. Pease, Pittsfield.
- Knitting machines, Electrostatic device for circular. 1,301,673. C. Feig, Philadelphia, Pa.
- Knitting-machine attachment. 1,299,621. J. A. Ruth, Marion, N. C.
- Loom. 1,300,121. A. E. Chernack, Providence, R. I.
- Loom lug-stick. 1,300,147. S. D. Eubanks, Concord, N. C.
- Loom-shuttle. 1,300,102. A. Archer, Fulwith Grange, near Harrogate, England.
- Loom, Pile-fabric. 1,298,949. H. J. Hope, Sanford, Me.
- Looms, Mechanism for automatically changing shuttles in. 1,298,860. M. Auerbach, Bremen, Germany.
- Looms, Batten structure for narrow-ware. 1,301,900. F. Benz, Jr., Haledon, N. J.
- Looms, Feeler mechanism for automatic. 1,302,039. U. Hebert, Manchester, N. H.
- Loom-picking mechanism. 1,301,298. A. Newton-Smith, Westminster, England.
- Looms, Weft-thread-controlled electrically-actuated auxiliary mechanism for. 1,301,280. C. D. Lanning, Boston, Mass.
- Loom for weaving and cutting pile fabrics. 1,300,306. A. Veluard, Philadelphia, Pa.
- Loom weft-feeler mechanism. 1,300,971. S. S. Jackson, Boston, Mass.
- Loom weft-feeler mechanism. 1,301,082. S. S. Jackson, Boston, Mass.
- Ribbon-roll attachment. 1,300,974. W. A. Johannsen, Paulina, Ia.
- Ribbons, Gumming edges of. 1,300,394. J. H. Hoffman, New York.
- Spinning or winding machine builder mechanism. 1,299,639. W. E. Walsh, Lowell, Mass.
- Shuttles, Threading-eye for. 1,301,437. W. Routledge, Middlesex, England.
- Spinning and like machines, Lappet for. 1,302,029. J. S. Gaunt and H. Dyson, Manchester, England.
- Undergarment, Combination. 1,301,399. S. E. D. Deane, Wrentham, Mass.
- Wool-drier conveying device. 1,301,177. F. G. Sargent, Westford, Mass.
- Yarn-cleaner. 1,301,133. R. G. Jennings, Elmira, N. Y.
- Yarn, Method of and apparatus for beaming. 1,301,665. J. F. Doyle, Tauton, Mass.

ATLANTIC DYESTUFF COMPANY.

The Atlantic Dyestuff Co., whose works in Burrage, Mass., were destroyed by fire last February, announce that the work of rebuilding has proceeded far enough to allow the company to resume the manufacture of sulphur black, while the manufacture of other colors and chemicals is well under way. This company's main offices are in the Ames Building, Boston, and its branch offices are at 334 Westminster Street, Providence; 230 W. 13th Street, New York; 1530 Real Estate Trust Building, Philadelphia and 706 Commercial National Bank Building, Charlotte.

NEW PUBLICATIONS.

Practical Dry Cleaner, Scourer and Garment Dyer; by W. T. Brantt and J. B. Gray; fifth edition, illust., 368 pages, 4 $\frac{1}{2}$ x7 $\frac{1}{4}$; Henry Carey Baird & Co., New York; \$3.00.

The growing realization of the importance of dry cleansing in improving the appearance and health of the individual, as well as reducing the cost of apparel, also the improvements in the mechanical and chemical operations have made it necessary to issue a new edition of this work, which has been revised and enlarged to bring it up to date. The contents are arranged under the following heads: Dry, Chemical or French Cleaning; Removal of Stains, or Spotting; Wet Cleaning; Finishing Cleaned Fabrics; Cleaning and Dyeing Furs, Skin Rugs and Mats; Cleaning and Dyeing Feathers; Cleaning and Renovating Felt, Straw and Panama Hats; Bleaching and Dyeing Straw and Straw Hats; Cleaning and Dyeing Gloves; Garment Dyeing; Stripping Colors from Garments and Fabrics; Analysis of Textile Fabrics; Practical Chemistry for the Cleaner and Dyer.

Grammar of Textile Design.—By H. Nisbet; 491 pages 5x8 $\frac{1}{4}$, illust; Scott, Greenwood & Son; Price, \$7.50.

The second edition of this work, recently published, has been carefully revised and enlarged by the addition of new matter, to bring it up to date. The contents are arranged under the following heads: Twill and Kindred Weaves; Diamond and Kindred Weaves; Bedford Cords; Backed Fabrics; Fustians; Terry and Loop Pile Fabrics; Gauze and Net Leno Fabrics; Leno Brocade Fabrics, Tissue, Lappet, and Swivel Figured Fabrics; also Ondule Fabrics; Brocade Fabrics Damask Fabrics; Alhambra and Kindred Fabrics; Piques or Toilet Welts; also Matelasse Fabrics; Toilet Quilting Fabrics; Patent Satin or Mitcheline Fabrics, Tapestry Fabrics; also Kidderminster or Scotch Carpet Fabrics.

Cost Accounting; by J. Lee Nicholson, C. P. A., and John F. D. Rohrbach, B. C. S., C. P. A.; 549 pages 5 $\frac{1}{2}$ x8 $\frac{1}{4}$, illust; The Ronald Press, New York; \$6.00.

Textile manufacturers cannot know too much about cost finding, a sound system for which is of vital importance to every mill. The authors have prepared this work on cost accounting with the object of adapting it to the needs of the accountant, manufacturer and student. Forms and records for each operation are illustrated and explained, and there is an extensive table of depreciation rates, also a section on the classification and distinction between asset and perishable tools, all of which will aid in establishing a sound rule for handling these items. Many excellent forms are given, the contents being arranged under seven principal heads: Elements and Methods of Cost-Finding; Factory Routine and Detailed Reports; Compiling and Summarizing the Cost Records; Controlling the Cost Records; The Installation of a Cost System; Simplified Cost Finding Methods; Cost-Plus Contracts.

Natural Organic Coloring Matters; by Arthur George Perkin, Professor of Color Chemistry and Dyeing in University of Leeds, and Arthur Ernest Everest, of the Wilton Research Laboratories; 629 pages 5 $\frac{1}{2}$ x8 $\frac{1}{2}$; Longmans, Green & Co., London and New York; \$9.00.

Natural dyestuffs have been largely displaced by the artificial products, but certain natural dyes still occupy an important and fairly secure position in the industries. Logwood, fustic, Persian berries and cutch are still in extensive use. These and other natural colors are also used for coloring foodstuffs, oils and various preparations, for which they are well adapted on account of their harmless nature. Furthermore, there is always the possibility of scientific discoveries and improvements in processes by which the natural dyes will regain some if not all of the ground lost in the contest with coal-tar products. These are the facts that make the work by Profs. Perkin and Everest a valuable addition to the literature of dyeing and color chemistry. It is a strictly technical treatise devoted to the chemical composition and application of the natural coloring matters, which are grouped under nineteen heads. There is a list of the natural dyestuffs which gives the scientific and commercial names, the part employed and the color produced, and an excellent index enables quick reference to be made to any subject or dyestuff. Until this book appeared the best work on natural dyes was a German handbook published in 1900, which has not been translated in English. This serious deficiency in the English literature on dyestuffs is now supplied by a work for whose reliability the names of the authors are a guarantee.

One Branch of a Giant Industry

TEXTILES comprise fabric and color. The fabric is right when the color is right. They stand or fall together. This is why the dyestuff producer must consider his work as a factor in a larger industry.

The textile industry is a great industry. Its annual output is valued at more than one billion dollars. But it is singularly dependent upon the dyestuff producer. Fabric without color is unthinkable.

The National Aniline and Chemical Company, Inc., recognizes this relation to the textile consumer. It is here to serve the textile industry. It is dependent upon that industry for encouragement and for existence. If it does not serve that industry adequately it will have no reason for existence.

The production of dyestuffs is a share in the work of a giant industry.

National Aniline & Chemical Company
INCORPORATED

21 Burling Slip, New York

Works: Buffalo Brooklyn Marcus Hook

Dyestuffs and Chemicals

H. A. METZ & CO.

INCORPORATED

122 HUDSON STREET
NEW YORK CITY

BOSTON CHICAGO
PHILADELPHIA PROVIDENCE
ATLANTA CHARLOTTE
SAN FRANCISCO



In hoc signo vincimus

DYE EXCHANGE CORPORATION

Clearing House for Colors

141 BROADWAY, NEW YORK



HELLENIC COLORS

Choicest Collection of Dyes, Dry Colors
and Oil Soluble Colors available anywhere.

Based on European Standards

Priced Below Average Market

Specialties: Malachite Green Crystals—Fuchsine
(Magenta) Crystals—Methyl Violet Crystals and All
Other Basic Colors, Direct Colors and Acid Colors

HELLENIC CHEMICAL & COLOR CO.

INCORPORATED

240 Broadway

New York City

ANALYZING CLOTH.

(Continued from page 25.)

- (n) Grains per square yard = $7,000 \div \text{sq. yds. per lb.}$
 (o) Square yards per pound = $16 \div \text{ozs. per sq. yd.}$
 (p) Square yards per pound = $840 \div (36 \times \text{grains per } 1/300\text{th sq. yd.})$
 (q) Square yards per pound = $7,000 \div (300 \times \text{grains per } 1/300\text{th sq. yd.})$
 (r) Running yards per pound = $840 \div (\text{width in inches } 1/300\text{th sq. yd.})$
 (s) Weight after boiling $\times 1.05 =$ vegetable material.
 $\times \text{grains per } 1/300\text{th sq. yd.}$
 (t) Weight of vegetable material \div weight before boiling
 $= \%$ of vegetable material.
 (u) $100 - \% \text{ vegetable fibre} = \% \text{ animal fiber.}$

The use of these formulas for analyzing a cotton and wool mixed fabric is illustrated as follows:

Example—A sample of woolen cloth with an area of 1-300th square yard (1.8 in. x 2.4 in.) weighs 10.4 grains. There are 96 warp threads on the long side of the sample and 65 filling threads on the short side. The warp yarn weighs 5.4 grains, and the filling yarn 5 grains. The goods are finished 55 inches wide. A sample of the same cloth weighs 18 grains before boiling out and 3.6 grains after boiling. The shrinkage in finishing is estimated at 6 per cent. in length and 15 per cent. in weight. The shrinkage of filling yarn is estimated at 12 per cent.

- $96 \div 2.4 = 40$ warp threads per inch
 (a) $40 \div 5.4 = 7.4$ cotton No. of woolen warp.
 (d) $7.4 \times .52\frac{1}{2} = 3.9$ runs, warp.
 (g) $(3.9 \times .85) \div .94 = 3.5$ runs, spun warp.
 $65 \div 1.8 = 36$ filling threads per inch.
 (a) $36 \div 5 = 7.2$ cotton No. of woolen filling.
 (d) $7.2 \times .525 = 3.8$ runs, filling.
 (g) $(3.8 \times .85) \div .88 = 3.7$ runs, spun filling.
 (j) $10.4 \text{ grains} = 10.4 \text{ ozs. per yard } 52\frac{1}{2} \text{ in. wide.}$
 (s) $3.6 \times 1.05 = 3.8$ grains of cotton.
 (t) $3.8 \div 18 = 21.1$ per cent. of cotton.
 (u) $100 - 21.1 = 78.9$ per cent. of wool.

KENT MFG. CO.'S BANQUET.

The annual banquet of the Kent Manufacturing Company, Clifton Heights, Pa., was held on June 21, at the Majestic Hotel, Philadelphia. A sumptuous feast was spread for the officers and employees of the company. The banquet hall was handsomely decorated with plants and flowers. The patriotic and electrical display proved very attractive. Addresses were made by Messrs. Everett L. Kent, President; Charles J. Webb, Treasurer; Joseph H. Parvin, Vice-President, and several department heads of the Kent Mfg. Co. Mr. Ernest R. Townson was toastmaster for the occasion. The banqueters were entertained with comedy sketches, singing and dancing. Among those present were:

Everett L. Kent, Charles J. Webb, Joseph H. Parvin, Ernest R. Townson, Russell H. Kent, Alan K. Keay, George C. Bevers, Kent Keay, O. L. Suenderhauf, August F. Keeler, Edward S. Davis, Spencer K. Lewis, Harry R. Jones, A. E. Berridge, G. H. Lawser, Lewis A. Daniels, Thomas Paulley, Burt McCarthy, James Dawson, Sr., James B. Scanlan, F. E. Brazeal, William Goodchild, Frank Lawson, Thomas F. Loftus, Robert McKeaige, Robert C. Liehr, Walter Livezey, Jos. Huart, Harry Taylor, A. V. Bogardus, Elmo Saunders, Russell McKeaige, B. W. Washburn, Warren Arnold, George Heininger, William Pilkington, William Bernard, Peter Yeager, Andrew Lichter, Chas. H. Martin, Frederick Kerswell, George Hartley, John Leigh, John Risco, Michael Risco, John Brophy, James McCann, John Gormley, Samuel Whelan, Wilmer Worrell, Thomas Newell and John McGoldrick.

ACID TANKS FOR TRANSPORT.

These tanks are designed to replace carboys hitherto used for railway transport of hydrochloric acid. Their construction is patented by British Dyes Ltd. They comprise a steel tank built up in sections and lined with ebonite which has been vulcanized on to the steel. Baffle plates are provided to prevent the acid from surging or splashing. The tank has a manhole, the lid of which has an inspection door and a filling bar attached thereto to indicate the height to which the tank is to be filled.—(Dyer and Calico Printer.)

FOR PROMPT SHIPMENT

<p>AZO BLUE AZO RUBINE BRILLIANT SCARLET 3 R CROCEINE SCARLET MOO FAST RED BENZOPURPURINE 4 B CONC. DIRECT BRILLIANT BLUE 3 B KANAWHA CHROME FAST BROWN R KANAWHA CHROME FAST BLACK D CROCEINE ORANGE ACID BORDEAUX</p>	<p>CLOTH RED ZETA SULPHUR BLUE R S S ZETA SULPHUR BLUE G S ZETA SULPHUR BLUE R S A ZETA BLACK ALPHA BLACK GALLOCYANINE SNEEZE BLUE ALIZARINE YELLOW R WEVA INDIGO SULPHUR OLIVE</p>
---	---

A. KLIPSTEIN & COMPANY
 644-652 GREENWICH STREET, NEW YORK CITY
 QUOTATIONS ON APPLICATION

JACQUES WOLF & COMPANY
 MANUFACTURING CHEMISTS AND IMPORTERS

<p>ALL SULPHONATED CASTOR OILS FINISHING PRODUCTS For Cotton, Wool and Silk. BENSAPOL For Scouring Wool. BLEACHING OIL Special Product for Bleacheries. BOIL-OFF OIL For Degumming Silk. GUMS Arabic, Karaya, Tragacanth, Textile.</p>	<p><i>Main Office and Works</i> PASSAIC, N. J. ◆ <i>New York Office</i> 100 WILLIAM STREET</p>	<p>MORDANTS & CHROME COLORS For Fabric Printing. HYDROSULPHITES (for all purposes) Stripping, Discharge Printing, Vat Colors and Indigo Discharge. ALIZARINE YELLOWS FAST GREEN PASTE CHROME BLACK MONOPOLE OIL U. S. Pat. 861397 Serial 367303.</p>
--	--	--

WESTERN REPRESENTATIVES
 UNITED INDIGO & CHEMICAL COMPANY, Ltd., 218 West Kinzie Street, Chicago, Illinois

PROVIDENCE DYE WORKS
 PROVIDENCE, RHODE ISLAND

*Dyers of Cotton Yarn
 in skeins*



Yarns Wound
on Cones and
Tubes.

Our Customers
Recommend Us to
Their Friends



PURE WATER LESS SECONDS

Pure water is necessary in the making of delicate tints and the satisfactory bleaching of goods.

NORWOOD FILTERS

are guaranteed to produce perfectly clean water. Less time and less cleanser is required to wash with water filtered by a NORWOOD FILTER.

Tell us the quantity and kind of water you use, and the source it is secured from, and we will tell you what a NORWOOD FILTER to meet your needs will cost. Write TODAY.

NORWOOD ENGINEERING CO.
FLORENCE, MASS.



HIGHEST QUALITY AT MINIMUM COST

A trained corps of chemists in our laboratories and an experienced selling organization, both versed in the intricate color requirements of each individual industry are at your command ready to serve you.

New Additions to Our Line:

NEWPORT FAST ACID VIOLET 10 B
NEWPORT ACID VIOLET 4 B S
NEWPORT DIRECT BLACK E
NEWPORT CHROME RED A 4 B
NEWPORT DIRECT FAST BLUE R W
NEWPORT DIAZO BLACK R S

NEWPORT CHEMICAL WORKS
INCORPORATED

PASSAIC, N. J.

General Offices—MILWAUKEE, WISCONSIN

Works—Carrollville, Wis.; Passaic, N. J.

Sales Offices—Passaic, N. J.; New York, N. Y.; Boston, Mass.; Greensboro, N. C.; Philadelphia, Pa.; Chicago, Ill.

THE KNIT GOODS EXHIBITION.

The annual exhibition of the National Association of Hosiery and Underwear Manufacturers, at the Commercial Museum building, Philadelphia, early in June, was well attended and highly successful. The exhibition of machinery and supplies was very interesting as well as the large display of knit goods made by various manufacturers of underwear, hosiery, sweaters and other knit goods. Secretary C. B. Carter of the National Association is entitled to much credit for the excellent manner in which he managed the details of the exhibition. There were a very large number of exhibitors, some of them being the following:

Hemphill Co., Pawtucket, R. I., a fine exhibit of the well known "Banner" automatic knitting machines. Hosiery men were very much interested in this exhibit, which included the new "Banner" spring beard needle machine, which is in great demand for the manufacture of silk stockings and other high grade hosiery.

Wildman Manufacturing Co., Norristown, Pa. This company exhibited the well known Wildman ribbers, flat fabric machines for making underwear, bathing suits, etc., also hosiery knitters. The exhibit also showed the Wildman stop motions.

Philadelphia Drying Machinery Co., Philadelphia, Pa. Exhibit of the famous "Hurricane" machinery for dyeing, drying and finishing hosiery and underwear. Various types of this company's machines were shown by models.

Acme Knitting Machine & Needle Co., Franklin, N. H. Exhibit of the well known "Acme" high speed hosiery knitters with the latest improvements.

Bradley Stencil Machine Co., New York. Exhibit of the latest model visible cutting stencil machines, stencil filing cabinet and other Bradley specialties.

Borne, Scrymser Co., New York. Exhibit of "Breton" oils for wool, "Paragon" and "Union" Apron oils, "Crystal knitting" oils, also one showing many finished products made with the aid of Borne, Scrymser Co. products.

Eastman Machine Co., Buffalo, N. Y. Working exhibit of "Eastman" cutting machines, fourteen different models being shown.

Merrow Machine Co., Hartford, Ct. Working exhibit of sewing machines for finishing hosiery, underwear, etc.

M. M. McCormick & Co., Philadelphia. Reception booth for meeting the firm's many knitting needle customers.

Textile Yarn Agency, New York and Philadelphia. Woolen and worsted knitting yarns.

Universal Cutter Co., St. Louis, Mo. Exhibit of its fine line of electric cloth cutting machines.

Union Special Machine Co., Chicago. Working exhibit of sewing machines for producing mock seam hose, for sewing tubing on underwear and other purposes.

Atlantic Dyestuff Co., Boston. Sulphur flock and other dyestuffs this company is now making in considerable quantities.

Economy Baler Co., Ann Arbor, Mich. Exhibit of both hand and power presses for baling underwear and other textile products.

National Aniline & Chemical Co., New York. Interesting exhibit of American made dyestuffs. Samples of finely dyed hosiery were shown.

Roessler & Hasslacher Chemical Co., New York. Exhibit of peroxide bleach, together with a display of textile goods bleached with the company's products.

Smith & Furbush Machine Co., Philadelphia. This space was neatly fitted up with large pictures illustrating the fine line of preparatory machinery built by this company.

William Whitman Co., Boston. Exhibit of yarns made at various well known mills.

NATIONAL ANILINE & CHEMICAL CO.

At a meeting of the board of directors of the National Aniline & Chemical Company, Inc., held on June 24, the resignation of William J. Matheson, as chairman of the board and president of the company, was accepted with great regret and high appreciation of his signal service to the company during the critical period following organization. Mr. Matheson was induced to undertake the executive leadership of the company in 1917 only as a patriotic duty for the period of the war, and his present resignation was tendered accordingly.

Orlando F. Weber, a member of the board of directors since the organization of the company and who has been acting as president of the company in the absence of Mr. Matheson, was elected chairman of the board and president to succeed Mr. Matheson.

PERSONALS.

W. D. Ingle, formerly assistant superintendent of the Maginnis Cotton Mills, New Orleans, La., has been appointed superintendent of the Steel Mills, Rockingham, N. C.

John F. McNamara, formerly at Bound Brook (N. J.) Woolen Mills, has accepted the position of superintendent, of George W. Lefferts Co., Inc., Philadelphia.

W. P. Clevinger has taken the position of overseer of finishing at the Hampshire Woolen Co., Ashuelot, N. H. He comes from Canton Junction, Mass.

William Bohrisch, formerly of Philadelphia, Pa., has accepted the position of assistant to the manager at the Garfield (N. J.) Worsted Mills.

J. H. Bagwell is now superintendent of the Union Cotton Mills of La Fayette, Ga. He comes from Irwin Mill No. 2, Duke, N. C.

J. F. Langston, formerly overseer of weaving in the Aragon Mill of Rock Hill, S. C., has accepted the same position at the Union Cotton Mill, La Fayette, Ga.

Victor Hemphill, for many years associated with Walter S. McCarthy, of Philadelphia, Pa., has established a business under the name of Hemphill & Co., Inc., at 114 South Front St., Philadelphia, to deal in wools, noils, hair and waste. Mr. Hemphill is president of the company.

W. H. Gray, formerly of Woodruff, S. C., has been chosen president of the Necronsett Mill, Cumberland, N. C.

W. D. McDonald has been promoted from assistant superintendent to general superintendent of Dillon Mills, Hamer, S. C.

W. S. Porter has taken the position of overseer of the warping, slashing and drawing-in departments of the Maginnis Mills, New Orleans, La.

Richard Wood, formerly of Chester, Pa., recently accepted the position of designer for the Alta Vista (Va.) Cotton Mills.

James J. Grady, formerly at New Brunswick, N. J., has accepted the position of overseer of carding for the General Asbestos & Rubber Co., Charlestown, S. C.

Thomas E. Ainley, who comes from Bloomsburg, Pa., has accepted the position of overseer of carding for the Meredith (N. H.) Linen Mills.

BETSON PLASTIC FIRE BRICK CO.

The Betson Plastic Fire Brick Co., Inc., of Rome, N. Y., was recently incorporated with Frank J. Jewell as president and secretary, and Nelson Adams as vice-president and treasurer. This company manufactures plastic fire brick for boiler furnace linings and baffle walls and Hi-Heat cement for boiler room uses.

SPUN SILK YARNS

MADE ESPECIALLY FOR KNITTING AND HOSIERY

In the Grey or Dyed on Cones as Wanted.

American Silk Spinning Co., Providence, R. I.

BLEACHERS!

Your selling agent may ask you any time for a bleach fit to compete with the Peroxide white.

He may be up against it with the present bleach you turn out.

He must guarantee the strength of the goods and the permanency of the white, but can he? Are his goods as soft and elastic?

In that case--or rather before--ask us to teach you Peroxide bleaching (without charge).

THE ROESSLER & HASSLACHER CHEMICAL CO.
New York

S. R. DAVID & COMPANY, Inc. DYESTUFFS, CHEMICALS, Etc.

Telephone Main 1684

100 PURCHASE ST. - - - BOSTON, MASS.
Well equipped Laboratory for matching and testing

MERION WORSTED MILLS

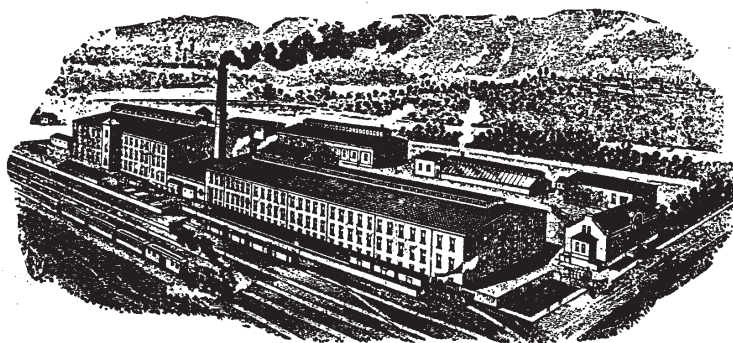

SELL DIRECT

Fine French-Spun Worsted and Worsted Merino Yarns

WHITE NATURAL AND FANCY MIXES IN SINGLE AND PLY FOR KNITTING AND WEAVING Mill and Office WEST CONSHOHOCKEN, PA.

WE ARE OFFERING AN **ARTIFICIAL SILK YARN**

ADAPTED TO THE KNIT GOODS TRADE

ALSO REAL SILK

SAMPLES AND QUOTATIONS ON APPLICATION

MINDLIN & ROSENMAN

105-107 EAST 29th STREET, NEW YORK

The Quality of Cheney Yarns

The same quality that has made CHENEY SILKS famous the world over has popularized these yarns with manufacturers who pride themselves on the superiority of their product.

Cheney Silk Yarns

Furnished in reeled silks (singles, tram or organzine)—in the gum, boiled out or dyed—in hanks, on spools, cones, tubes or shuttle bobbins, these yarns may be had in the form that best suits your individual manufacturing requirements.

CHENEY BROTHERS
Silk Manufacturers
4th AVE and 18th ST NEW YORK CITY

BOILING-OFF SILK.

(Continued from page 23.)

Silk pieces are boiled off under tension in a machine similar to the jigger that is used extensively in the dyeing of cotton goods, but the silk machine is generally larger. It usually consists of a rectangular tub made of metal and carrying at each end a large roller. The piece is rolled alternately on each of these two rollers, between which are a series of smaller rollers placed alternately at the bottom and top of the tub, and over which the piece moves while completely immersed and under tension in the soap bath during the passage between the two end rollers. The tension which occurs each time that the piece is wound on an end roller facilitates the removal of the dissolved gum.

LOWELL TEXTILE SCHOOL.

The commencement exercises of the Lowell Textile School were held on June 10. After some words of welcome by A. G. Cumnock, chairman of the board of trustees, an address was delivered by Dr. F. W. Hamilton, of the State Board of Education. Degrees were then conferred on the graduates as follows:

Bachelor of Textile Chemistry: Arthur J. Anderson, Carroll L. Brainerd, Charles A. Everett, Francis C. Gooding, Norman C. Gould, Arthur N. Hart, Hector G. Macdonald and Raymond R. Stevens.

Bachelor of Textile Engineering: Gilbert R. Merrill, Frank M. Sanborn and Tsun Kwer Woo.

Diplomas were awarded as follows:

Cotton Manufacturing: George J. Almquist.

Wool Manufacturing: Léon R. Mirsky.

Awards for proficiency in chemistry: Harold D. Forsyth, Dean W. Symmes, Arthur R. Thompson, Jr., and Andrew S. Orr.

National Association Cotton Manufacturers Medal: Norman C. Gould.



Established 1868

UNDERWEAR MANUFACTURERS!

Why not grind your napper rolls on a

ROY GRINDER

and treble the life of your Clothing

WRITE FOR BULLETIN

B. S. ROY & SON CO. - Worcester, Mass.

CLIFT & GOODRICH

328-330 Broadway

Established 1891

New York, U. S. A.

Sales Agent

KNIT UNDERWEAR—SWEATER COATS

WE are exclusive selling agents for FIFTY-TWO MILLS producing all grades of underwear in all weights and in all fabrics for all climates in every part of the world.

Our lines consist of—

Flat and ribbed wool and flat and ribbed cotton underwear in shirts, drawers, vests, pants and union suits for men, women and children.

There is no requirement in popular priced underwear that we cannot supply to the wholesale and export trade.

Our line of popular priced Sweater Coats is also complete for all demands.

KNIT UNDERWEAR—SWEATER COATS

Books for the Textile Industries

Any of these books sent postpaid on receipt of price

Address TEXTILES, 79 Milk St., Boston, Mass.

SILK.

The Harbred Silk Co., of Scranton, Pa., are erecting an addition to their plant. Several hundred more persons will be given employment when the factory is completed.

The Susquehanna Silk Mills, of New York, has awarded a contract for the erection of an addition to their plant in Milton, Pa.

The Hellwig Silk Dyeing Co., of Wisconsin, Pa., will in the near future erect a dye house.

W. P. Hamrich, general superintendent of the Olympia Mills, Columbia, S. C., will soon move into a new dwelling just finished by the company. This dwelling is the largest, best arranged, most costly ever built in the South by any textile mill for any superintendent.

Joseph Castleberry, formerly at the Manchester Cotton Mills, Macon, Ga., has accepted the position of overseer of carding at the Georgia Cotton Mill, No. 2.

George Fuller has taken the position of overseer of weaving with the Parkside Mills, Inc., Philadelphia, Pa.

Paul Nuckols has been appointed superintendent of the waste plant at the Indian Head Mills, Cordova, Ala. He comes from Atlanta, Ga.



**Specializing in Silk Soaps
also High Grade Fulling and
Scouring Soaps**

SAVES SOAP



SAMPLE FREE

**The Electric Smelting
& Aluminum Co.
LOCKPORT, N. Y.**

GENERAL SUBJECTS



Science of Knitting

By Ernest Tompkins. A valuable handbook for knitting mill men. Gives in convenient form much useful information on knitting. The lack of books on knitting increases the value of this work, which is written by one who is thoroughly posted on the subjects he discusses. 330 pages, 4x6 $\frac{3}{4}$; 140 illustrations and tables; leather.
Price \$3.00

Power Transmission by Leather Belting

By Robert T. Kent. Presents in concise form the methods of designing belt drives in accordance with modern practice. Contains tables and information facilitating the solution of any problem in belt driving that may arise within the limits of ordinary practice. 122 pages, 5 $\frac{1}{4}$ x8; 31 illustrations; cloth.
Price \$1.25

Jacquard Mechanism and Harness Mounting

By Fred Bradbury. A complete handbook dealing with the construction and operation of the jacquard loom. A book for the overseer, designer and loom fixer. Goes into the subject thoroughly. 347 pages, 5x8 $\frac{1}{4}$; 358 illustrations; cloth.
Price \$4.00

Materials used in Sizing

By W. F. A. Ermen. A revised edition of a course of lectures before the Manchester (Eng.) School of Technology. Is filled with useful information on the very important subject of sizing. 126 pages; illustrated; cloth.
Price \$2.00

Jacquard Weaving and Designing

By T. F. Bell. A clear explanation of the jacquard mechanism and process of weaving, written by a man versed in both the practice and theory. Covers the subject from the simplest patterns to the more complicated designs, including lappet and swivel weaving. 300 pages; 199 illustrations; cloth.
Price \$4.00



Jute and Linen Weaving

By Thomas Woodhouse and Thomas Milne. Thoroughly practical work on the mechanics of jute and linen weaving. Adapted for overseers of weaving, loom fixers and students. Covers reeling, bundling, warp and weft, winding, warping, beaming and dressing, drawing-in, reeding, shedding, tappet setting, shedding motions, jacquard weaving, picking, beating up, let-off and take-up motions, box-motions, stop-motions, temples, Turkish and terry towel motions, automatic filling motions, selvage motions. 582 pages, 4 $\frac{1}{2}$ x7. 305 illustrations.
Price \$4.25

Jute Spinning

By Wm. Leggett. A thoroughly practical handbook of jute spinning from fibre to yarn. Written by a jute mill manager of long experience. All the operations and machines are clearly described and illustrated. Tables for speeds, drafts, production, waste, etc. Intended for those who want to learn the jute business, the volume is also of value to experienced men. 284 pages, 7 $\frac{1}{4}$ x10; illustrations; cloth.
Price \$4.00

Spinning and Twisting Long Vegetable Fibers

By H. R. Carter. A very complete account of the machinery and processes for preparing, spinning and twisting flax, hemp, jute, ramie and other long fibers, including the manufacture of thread, twine and rope. 360 pages; 161 illustrations and 10 plates; cloth.
Price \$5.00

Preliminary Operations of Weaving

By H. Nisbet. A very complete work on an important subject, the preparation of yarn for the loom, which is treated under the following heads: varieties of yarns, knots and knot tying, beam warping, slashing, drawing-in, twisting-in and tying-in. A valuable book for manager and overseer, as warps well prepared for the loom are half woven. 380 pages, 5x8 $\frac{1}{2}$; 200 illustrations.
Price \$2.50



Mechanism of Weaving

By T. W. Fox. Weaving overseers, loom fixers and students will find in this book the practical information they need regarding the construction and operation of looms. The contents are arranged under the following heads: power loom, heddles, shedding, over and under motions, jacquard shedding, figuring harness, card cutting, lappets picking, pickers, straps and buffers, fast and loose reeds, shuttle guards, box motions, swivel weaving, the reed, beating-up, terry motions, warp and filling stop motions, warp let-off motions, take-up motions, temples, selvage motions, loom adjustments, weaving sheds. Fourth edition. 588 pages, 4 $\frac{1}{2}$ x7; 282 illustrations.
Price \$3.25

We sell all books on textile subjects which are not out of print. Write for Catalog.

EMPLOYMENT DEPARTMENT

WHERE EMPLOYERS AND EMPLOYEES MEET

SITUATIONS WANTED.

Overseer of Spinning and Superintendent. 16 years' experience on all kinds of hard yarns. Yarns, sheetings and print goods. Age 28. Married. Address Box 252, TEXTILES, 79 Milk St., Boston, Mass.

Overseer of Woolen Spinning. Nineteen years' experience. Cotton and merino yarns, also cone winding, reeling and twisting. Age 43. Married. Address Box 303, TEXTILES, 79 Milk St., Boston, Mass.

Superintendent or Overseer of Carding. 35 years' experience as overseer and superintendent. Yarns and cloth. Age 50. Married. Address Box 243, TEXTILES, 79 Milk St., Boston, Mass.

Cloth Room Overseer. 10 years' experience. Plain weave cotton goods. Age 36. Married. Address Box 244, TEXTILES, 79 Milk St., Boston, Mass.

Boss Dyer in Large Mill. 15 years' experience on raw stock yarn and piece dyes. Unions, cassimeres, worsted and uniform cloth. Age 34. Married. Address Box 232, TEXTILES, 79 Milk St., Boston, Mass.

Bleacher. Twelve years' experience. Cotton underwear. Age 45. Married. Address Box 280, TEXTILES, 79 Milk St., Boston, Mass.

Overseer of Dyeing. Twelve years' experience. Cotton Indigo blue. Age 45. Married. Address Box 282, TEXTILES, 79 Milk St., Boston, Mass.

Overseer of Weaving. 18 years' experience. Plain and drills. Age 47. Married. Address Box 262, TEXTILES, 79 Milk St., Boston, Mass.

Cotton Mill Superintendent. Eight years' experience as carder and spinner and one year's experience as superintendent. Age 34. Married. Address Box 292, TEXTILES, 79 Milk St., Boston, Mass.

Hosiery Mill Superintendent. 13 years' experience. Hosiery and Hard Yarns. Age 45. Married. Address Box 225, TEXTILES, 79 Milk St., Boston, Mass.

Overseer of Cloth Room. 3 years' experience. Sheetings, Ducks, Osna-burgs. Age 28. Married. Address Box 226, TEXTILES, 79 Milk St., Boston, Mass.

Overseer of Weaving. 8 years' experience. Plain sheeting. Age 35. Married. Address Box 241, TEXTILES, 79 Milk St., Boston, Mass.

Cotton Mill Superintendent. 14 years' experience as overseer of spinning and assistant superintendent. Plain sheetings. Age 39. Married. Address Box 240, TEXTILES, 79 Milk St., Boston, Mass.

Overseer Spinning and Twisting. 2 years' experience as overseer and 8 years as second-hand. Age 32. Married. Address Box 304, TEXTILES, 79 Milk St., Boston, Mass.

Cotton Mill Superintendent. Fourteen years' experience as overseer and assistant superintendent. Yarns and cloth. Age 40. Married. Address Box 209, TEXTILES, 79 Milk St., Boston, Mass.

Overseer of the Cloth Room. 12 years' experience. White, plain and fancies. Age 29. Married. Address Box 298, TEXTILES, 79 Milk St., Boston, Mass.

Superintendent. 15 years' experience. Various kinds of worsted and cotton goods, both fancy and plain. Age 48. Married. Address Box 277, TEXTILES, 79 Milk St., Boston, Mass.

Overseer of Weaving. 20 years' experience. Drills and sheetings. Age 47. Married. Address Box 250, TEXTILES, 79 Milk St., Boston, Mass.

Overseer of Dyeing. 3 years' experience. Denims. Age 32. Married. Address Box 275, TEXTILES, 79 Milk St., Boston, Mass.

Overseer of Dyeing. 30 years' experience. Fancy dress goods and denims and gingham. Age 58. Married. Address Box 276, TEXTILES, 79 Milk St., Boston, Mass.

Overseer of Weaving. Four years' experience as second-hand and 18 months as overseer. Sheetings and heavy twill goods. Age 35. Married. Address Box 278, TEXTILES, 79 Milk St., Boston, Mass.

Carder and Spinner. Twenty-four years' experience. Age 50. Married. Address Box 279, TEXTILES, 79 Milk St., Boston, Mass.

Overseer of Mule Spinning. 10 years' experience. Wool or cotton waste. Age 33. Married. Address Box 253, TEXTILES, 79 Milk St., Boston, Mass.

Cotton Spinning Overseer. Eight years' experience. Hosiery and warp yarn. Age 30. Married. Address Box 208, TEXTILES, 79 Milk St., Boston, Mass.

Foreman of Knitting Mill. 10 years' experience. 220 needle work. Married. Address Box 260, TEXTILES, 79 Milk St., Boston, Mass.

Overseer of Woolen Carding. 8 years' experience. Cotton or wool. Age 20. Single. Address Box 266, TEXTILES, 79 Milk St., Boston, Mass.

Cotton Carding or Spinning Overseer. Nine years' experience. Combed and carded yarns. Age 30. Married. Address Box 207, TEXTILES, 79 Milk St., Boston, Mass.

Overseer of Spinning. Eight years' experience. Any class of goods. Age 29. Married. Address Box 206, TEXTILES, 79 Milk St., Boston, Mass.

Cotton Carding or Spinning. Twen-and gingham. Age 50. Married. Address Box 213, TEXTILES, 79 Milk St., Boston, Mass.

Overseer of Spinning. Ten years' experience. Between 10s and 60s. Age 27. Married. Address Box 215, TEXTILES, 79 Milk St., Boston, Mass.

Carding or Spinning Overseer. 15 years' experience. Plain, fancy, white and colored. Age 40. Married. Address Box 231, TEXTILES, 79 Milk St., Boston, Mass.

Superintendent of Small Mill. 20 years' experience. 4s to 30s single or ply. Age 42. Married. Address Box 259, TEXTILES, 79 Milk St., Boston, Mass.

Overseer of Cotton Weaving. 3 years' experience as second hand; 6 years' experience as overseer. Age 39. Married. Address Box 258, TEXTILES, 79 Milk St., Boston, Mass.

Overseer of Carding and Spinning. 12 years' experience. Age 38. Married. Address Box 263, TEXTILES, 79 Milk St., Boston, Mass.

Superintendent or Boss Carder. 12 years' experience. Sheetings and Yarns. Age 41. Single. Address Box 228, TEXTILES, 79 Milk St., Boston, Mass.

Superintendent or Boss Weaver. 16 years' experience. Age 41. Married. Address Box 229, TEXTILES, 79 Milk St., Boston, Mass.

Fixer. Wildman ribbers. Can furnish references. Now employed as overseer and fixer. 7 years' experience. Address Box 273, TEXTILES, 79 Milk St., Boston, Mass.

Overseer of Spinning. 10 years' experience. Whitin. Age 39. Married. Address Box 274, TEXTILES, 79 Milk St., Boston, Mass.

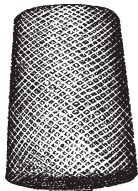

HARRY C. WERNICK

COTTON, WOOLEN and WORSTED YARNS

We specialize in these yarns

FOR IMMEDIATE DELIVERY

Wire or phone your wants at our expense

248 CHESTNUT STREET

Philadelphia, Pa.

Both Phones

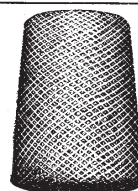

Established 1870

Incorporated 1890

The Warren Soap Manufacturing Company

77 Summer Street Boston, Mass.

National Silk Dyeing Company

Main Office, Citizens' Trust Co. Building,
Paterson, N. J.

New York Salesroom, 60 University Place.

Telephone 1551 Stuyvesant

SKEIN SILK DYEING

Of every description for all branches of
textile manufacture

Hosiery Dye A Specialty

WORKS:

Paterson, N. J.

Allentown, Pa.

Dundee Lake, N. J.

Williamsport, Pa.

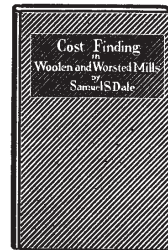

A Big Problem Solved

EVERY manufacturer of woolen and worsted yarn or fabric will find the new book "COST FINDING IN WOOLEN AND WORSTED MILLS" by Samuel S. Dale, invaluable.

A complete work on this subject, but easy to understand.

Write for particulars.

"TEXTILES"

79 MILK STREET, BOSTON, MASS.

FOR GREATER PRODUCTION AND LOWER COST

USE THE

PAYNE WINDER

Over 2,500 in Successful Operation in Progressive Hosiery and Underwear Mills

IMPROVED UPRIGHT SPOOLERS

To Spool from Cop, Skein or Bobbin. Doubling Spoolers for doubling 2, 3 or more ends into one. Upright Quillers, Quill from Cop, Skein or Bobbin.

Ring Dresser, Spooler and Reel Spindles, Cop Skewers, Warp, Spool, Spooler Guides, Bolsters, and Stops Made and Repaired at Short Notice.

GEO. W. PAYNE CO. 102 BROAD STREET
PAWTUCKET, R. I.

Established 1885—Incorporated 1903.

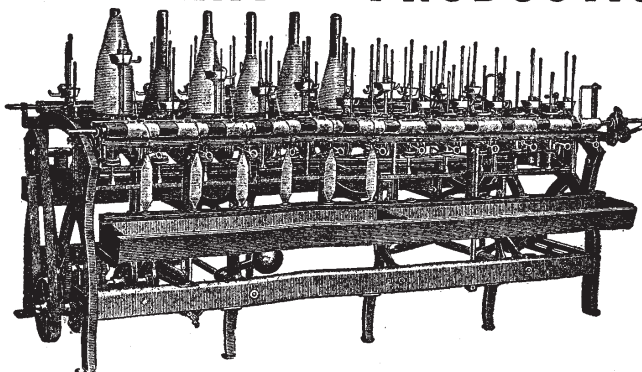

DELAHUNTY DYEING MACHINE CO.

ESTABLISHED 1890

Manufacturers of Textile and Mining Machinery.

Revolving Cylinder Raw Stock Dyeing and Bleaching Machines
 Revolving Cylinder Hosiery Dyeing and Bleaching Machines
 Hosiery, Oxidizing, and Tom Tom Machines
 Circulating Type Raw Stock Dyeing and Bleaching Machines
 Circulating Type Beam Dyeing Machines for Dyeing
 Cotton Warp on Beams, 1 to 12 Beams in One Operation

SPECIAL MACHINES FOR ANILINE, SULPHUR, INDIGO, AND OTHER VAT COLORS**OFFICE AND WORKS, PITSTON, PA., U. S. A.****WILDT & CO., Limited,****The Boulevard, Leicester, England****KNITTING MACHINE BUILDERS AND EXPORTERS***Please write for catalogues*

We are also open to negotiate for the import of American
 Underwear Machinery for the European market.

THE NEW BEDFORD TEXTILE SCHOOL

The New Bedford Textile School is now a cotton textile institute of the Commonwealth of Massachusetts. It is located in New Bedford, Mass., an attractive residential city situated on Buzzards Bay, and the largest producer of fine yarns and fancy woven fabrics in this country.

Diplomas are granted for completion of three years' study and practice in any one of the following courses: Cotton Manufacturing, Textile Designing, Carding and Spinning, Textile Chemistry (Dyeing and Finishing), Seamless Hosiery Knitting, and Latch Needle Underwear Knitting. Mechanical drawing, machine shop practice, steam, electrical and textile engineering given in connection with the above courses. Special shorter courses may be arranged for.

Tuition free to residents of Massachusetts

Illustrated catalogue supplied free on application.

WILLIAM E. HATCH, A.M., *President.***LOWELL TEXTILE SCHOOL**

Four-year degree courses in

CHEMISTRY AND TEXTILE COLORING — TEXTILE ENGINEERING

Degrees of B. T. C. (Bachelor of Textile Chemistry) and B. T. E. (Bachelor of Textile Engineering) offered for completion of prescribed four-year courses.

Three-year diploma courses in

COTTON MANUFACTURING**WOOL MANUFACTURING****TEXTILE DESIGNING**

Scientific and practical training in all processes of textile manufacture, including all commercial fibres.

Certified graduates of High Schools and Academies admitted without examination. For catalogue address

CHARLES H. EAMES, S. B., President, LOWELL, MASSACHUSETTS**THE FRANKLIN MACHINE COMPANY**

Providence, Rhode Island

OPERATING

FRANKLIN FOUNDRY & MACHINE SHOPS Telephone Union 963
HARRIS CORLISS ENGINE PLANT " " 1857

ENGINEERS**FOUNDERS****MACHINISTS**

Manufacturers of Harris Corliss Engines—Brown Valve Gear applied to all makes of Corliss Engines, Reborring Cylinders, Overhauling and Repairs on all kinds of Engines and Machinery—Shafting, Pulleys, Bearings, Couplings, Hangers, etc. Silk Spinning Machinery, French Worsted Drawing Frames (Frotteurs), Iron Castings and General Mill Repairs, Ball Winding Machines, Shoe Lace Tipping Machines, Cotton Bat Heads, Yarn Dressers, Special Machinery for Textile Work.

SILK.

The Berfelden Silk Co., Bethel, Ct., has awarded a contract for the erection of a mill addition to make room for 40 looms.

The John H. Meyer Silk Mills Company, of Bloomsburg, N. J., is erecting an addition which will increase its capacity 50 per cent. Their main mill is at Northampton, Pa.

The Pen Argyle (Pa.) Silk Co., is about to double its output and has plans prepared for the construction of a building. The company does throwing of organzine, tram and hard twists. It has about 14,000 spindles.

Storb Snader & Co., New Holland, Pa., are to erect an addition to their mill. It is stated that the addition will approximately double the size of the plant.

The Lenepa Silk Co., East Stroubsburg, Pa., a recently organized concern, will install an initial equipment of twenty-seven looms.

The Brookford (N. C.) Mills Co. is building an additional structure which is to be used as a weave shed to relieve congestion in the present plant.

The Pioneer Braid Manufacturing Co., South Norwalk, Ct., is erecting a branch plant to be equipped with 400 braiders. Silk, cotton and mohair braids, soutaches, spinning cords and novelties are to be produced. The company's main plant is in Meriden, Ct.

The Lincoln Silk Co., Paterson, N. J., has taken over a large warehouse at Marietta, Pa., and will remodel it for a branch factory. This company manufactures broad silks.

The Watson Silk Co., of Phillipsburg, N. C., has started a throwing plant in the building formerly occupied by the American Horse Shoe Company. The interior has been refitted and remodelled.

The National Spun Silk Co., of New Bedford, Mass., will erect a four-story spinning mill. This company manufactures spun silk yarns, noil yarns, and silk noils.

The Stewart Silk Co., of Easton, Pa., has recently awarded a contract for a new plant to provide for increased capacity.

The New Holland (Pa.) Silk Mill is arranging plans for the erection of a one and two-story addition to their plant.

The Davenport Hosiery Mills, of Chattanooga, Tenn., have accepted plans for a building. They will install therein 100 knitting machines for the manufacture of women's fancy silk hosiery.

Salembier & Clay, Inc., of Central Falls, R. I., are to erect an addition to their silk mills.

The Stanford Silk Mills have awarded a contract to Palmer and Dreher, local contractors, for the erection of a new addition to their plant.

E. P. Coffield has recently accepted the position of superintendent of the Brogan Mills, Anderson, S. C. Mr. Coffield started in the Brogan Mills seven years ago as bookkeeper in the cloth room and has been promoted in successive steps until he has now reached the position of superintendent.

WOOLEN AND WORSTED MILLS

The Park Woolen Mills, of Rossville, Ga., will in the near future build an addition, in which they will install 40 wide looms.

The French Worsted Co., of Woonsocket, R. I., will erect an addition to their plant.

The Philmont Worsted Co., of Woonsocket, R. I., will erect a building in which they will manufacture woolen and worsted yarns on the Bradford system. Theophile Guerin is the general manufacturer.

The Cumberland Worsted Mills, of Woonsocket, R. I., will erect a one-story addition.

The American Woolen Co., of Maynard, Mass., will erect twenty houses for operatives soon. The houses will be six-room tenements with bath, light and every modern convenience.

The branch plant of the Mazuy Mills, of Newton, N. J., is to have 150 looms. They manufacture mercerized and silk brocaded corset cloths.

The International Worsted Mills of Methuen, Mass., have recently opened their new weave shed which is 92 feet long and will house 64 additional looms. They are now erecting an addition to the finishing department of their mills.

MILL NOTES

The John W. West Thread Co., of South Boston, Mass., will soon start work on alterations and additions to their mill.

The Calhoun Cotton Mills Co., of Aniston, Ala., are installing 20 wide looms to make ducking.

The Lindsey Light Co., Chicago, Ill., will open a new dye plant within a few days and expects that the output will average about 400 pounds of dyes daily within a month and 800 pounds daily by the end of 1919.

McCleary, Wallin & Crouse, of Amsterdam, N. Y., will erect a three-story building with two three-story additions and a one-story picker house. The new buildings will allow for assembling all the spinning machinery under one roof, and the installation of additional machinery.

A contract has been awarded to the Massachusetts Mohair Plush Co., Lowell, Mass., for the erection of a weave shed 304 by 360 feet.

John Gay's Sons, Inc., Park Carpet Mills, of Philadelphia, Pa., have awarded a contract for addition to their mills.

The Lexington (S. C.) Manufacturing Co. and the Saxe-Gothe Mills are changing over many of their old-style looms to the latest Draper models.

A Client Should Know

"Your cost system should prove of great value to any textile mill officer who is engaged in selling the product of his mill."
—A Client.

A copy of "Where Profits Go in Textile Plants" will be mailed free upon request. Write for it today.

RALPH E. LOPER
FALL RIVER, MASS.

Textile Production Engineer
Specialist in Textile Cost Methods

For Sale--30 Motors--Brand New

PURCHASED FOR WAR WORK AND NEVER USED

30 K. T. Frame, No. 140-6-1½ H. P. 1200 Revolutions, 220 Volt, 60 cycle, three phase, having special shaft for pinion ¾" in diameter in large end of taper, and having 1½" face, also having straight portion for quiller pulley.

15 motors have assembly No. 2 for RH Looms

15 motors have assembly No. 3 for LH Looms

equipped with oil tempered steel pinions, 12 teeth, 8 pitch, 1½" face, ¾" bore large end of taper.

Prices quoted on application

R. H. LONG COMPANY, FRAMINGHAM, MASS.

The Woonsocket (R. I.) Falls Mills will in the near future erect an addition to their plant.

The Cherryville (S. C.) Manufacturing Company have just completed an addition to their plant and will install therein 5,000 spindles.

The American Textile Art Printing & Dyeing Co., will start building a mill in the near future to be put in operation by next spring. Calico printing, spray printing, dyeing, bleaching and finishing on cotton, linen and silk is to be done.

The Burlington (N. C.) Textile Co., recently organized, will conduct a business as jobbers and manufacturers agents.

KNITTING

The Champion Knitting Mills, recently incorporated at East Chattanooga, Tenn., has secured a building and the machinery is now being purchased for a plant to manufacture men's and women's silk hose.

The Slatedale (Pa.) Knitting Mill is understood to be considering plans for the erection of an addition to their plant.

The Sunshine Hosiery Co., Murfreesboro, Tenn., has acquired and will soon occupy the old Bivin's property. The capacity of the mill is to be doubled.

The Shaker Knitting Mill Company, manufacturers of sweaters, jerseys, bathing suits and fancy knit goods, of Chicago, Ill., have moved to larger quarters.

Rudolph Schrieber of New York, will in the near future start a knitting mill for the manufacture of knit cloth.

The Durham (N. C.) Hosiery Mills will soon erect a bleachery. The company has ordered 350 additional knitting machines.

WANTED

Rag, mixing, burr and fearnought pickers. Cards, woolen or worsted, garnets, any condition. Card cylinders, frames, arches, feeds, condensers or parts of any kind used on cards. Mules, any gauge. Bobbins, spools, used belting and card clothing. Weaving, dyeing, and finishing machinery.

Will pay for information as to where any of above may be for sale. Send me list.

JOHN J. HEALY

Newtonville Mass.
Buy and sell all kinds of textile machinery.

FOR SALE

- 1—36" Bramwell Burr Picker.
- 1—36" Goddard Burr Picker.
- 1—30" Goddard Burr Picker.
- 3—30" Dodge Shoddy Pickers.
- 2 extra cylinders for Dodge Picker.

These machines are equipped with ball bearings and in good condition.

- 1—110" American Blower Steel Plate Fan, belt driven.
- 1 lot Pulleys and Hangers.

The American Pad & Textile Co.
Greenfield, Ohio.

J. K. LAMB TEXTILE MACHINERY CO.

SECOND-HAND TEXTILE MACHINERY

For cotton, woolen and worsted
246 Chestnut St. Philadelphia, Pa.

WANTED

Spinners for night shift, forty-eight hours per week of five nights. Good price list. Write to the

OREGON CITY MFG. CO.,
Oregon City, Oregon.

WANTED

Weavers and Spinners on
Fancy Woolens
CROWN MILLS

Marcellus, New York

AUTOMATIC LOOM SHUTTLES?

Send us today sample of your Automatic Loom Shuttle and get our price and delivery.

SHAMBOW SHUTTLE COMPANY
Woonsocket, R. I.

ESTABLISHED 1870
INCORPORATED 1890

CODE ABC
5TH EDITION

CRANE

SPRING AND LATCH NEEDLE KNITTING MACHINES

Will Enable Any User To Improve His Business

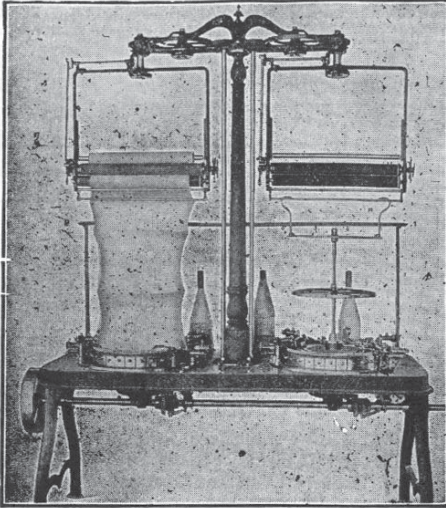

Spring Needle Underwear Machine

A splendid machine for balbriggan underwear, stockingettes, eiderdowns and all kinds of fleeced fabrics.

Made in large variety of sizes with automatic take-up, etc.

New Spring Needle Rib Machine

Has new style feed, stop motion and take-up features.

Especially made to produce high grade ribbed underwear. Will make finest fabric on the market. An ideal machine with all parts handy to get at.

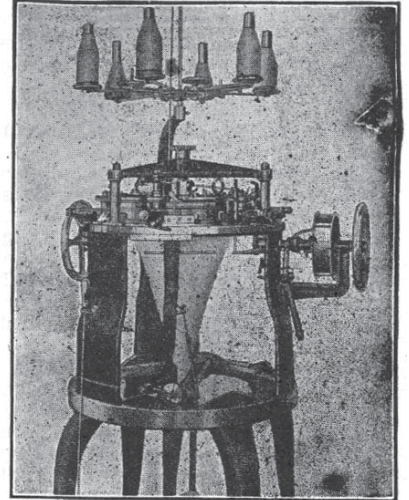

Improved Spring Needle Underwear Machine

New Spring Needle Rib Machine

Our late models challenge comparison. Write for further information.

CRANE MANUFACTURING CO. : LAKEPORT, N. H.

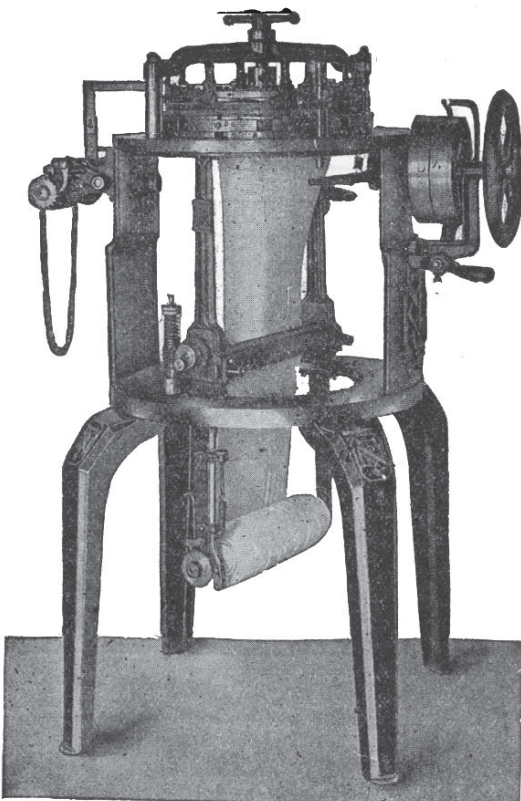

Circular Rib Knitting Machinery

For making Ribbed Underwear, Combination Suits, Cuffs, Shirt Borders, Ribbed Hosiery, Fancy Knit Goods, Etc.

CORRECT Construction, Excellence and Durability—Quality of Fabric and Production Unexcelled—Latest Improvements.

NYE & TREDICK COMPANY

718-720 Cherry Street

PHILADELPHIA - - - PA.

HOSIERY AND UNDERWEAR MANUFACTURERS.

The annual convention of this association was held in the rooms of the Commercial Museum on June 3, 4 and 5, with a somewhat smaller number than usual in attendance. The meeting was called to order by President T. H. Johnston, after which came an address of welcome by Jos. S. McLaughlin, of the city department of supplies. Addresses were delivered during the sessions by Harry H. Pratt, U. S. Dept. of Labor, on industrial training; J. H. Tregoe, on credits; C. S. Andrews, Chattanooga, Tenn., on standardizing the purchase and sale of textiles; Sim Beam, Kansas City, Mo., on co-operation; Mrs. Katherine Clemmons Gould, on foreign trade; Victor P. Sahrner, on direct selling; R. S. MacElwee, on irregularities in foreign trade; Charles L. Crandler, Philadelphia, on South American trade; Frank O'Malley, National City Bank, foreign trade.

Following this address a modification of the bylaws was unanimously adopted and the final order of business was the election of officers. These follow: T. H. Johnston, Knoxville Knitting Mills, re-elected president; D. L. Galbraith, American Textile Co., Bay City, Mich., former second vice-president, elected first vice-president; S. D. Bausher, Glorie Underwear Mills, Reading, Pa., to take the place of Mr. Galbraith as second vice-president; Robert C. Blood, of John Blood & Co., Philadelphia, re-elected treasurer; C. B. Carter,

Philadelphia; reelected secretary. Board of Directors were elected as follows: Joseph Felden, Roxford Knitting Co., Philadelphia, chairman; Eugene West, West Bros., Syracuse, N. Y.; R. A. Scott, Peerless Knitting Mills, Boston; J. J. Phoenix, Bradley, Knitting Co., Delavan, Wis.; Edward Blood, John Blood & Bro., Philadelphia; G. Oberlander, Berkshire Knitting Mills, Reading, Pa.; W. Park Moore, Hancock Knitting Mills, Philadelphia; Joseph H. Zens, Milwaukee (Wis.) Hosiery Co. The new names of this board are Messrs. Phoenix, Oberlander and Edward Blood. The convention then adjourned.

At the banquet on Thursday evening the principal speaker was ex-President Taft.

FABRIC TESTING.

A Swiss invention provides an apparatus in which fabrics undergo friction and other treatment similar to that which they would receive during wear. The machine comprises a fixed table over which a carriage reciprocates. The driving mechanism comprises a tank, belt, pulley, and counting mechanism. The fabric to be tested is attached at one end to the table and at the other end to the carriage so that it forms a close fold between them. The carriage is moved backward and forwards continuously so that the fabric is rubbed against its own surface until it is worn out. The test of wearing qualities can be increased by varying the weight of the carriage.

KNITTING.

The West Branch Knitting Co., of Milton, Pa., will install 45 new knitting machines when their new addition is completed. Women's hosiery will be manufactured.

The Rockledge Machine Works, Fox Chase, announce that they have taken over the business of the New Branson Knitting Machine Company, and will in the future make all machines, repair parts and needles formerly made by the company. The Branson Machine Company were among the pioneer builders of seamless hosiery machinery in this country.

The Shillington (Pa.) Hosiery Mill have just completed their new dye-house, which they have been erecting.

Samuel Antcliffe has accepted the position of overseer of dyeing for the East (Me.) Wilton Woolen Mills.

James Farrington has been appointed superintendent of the Versailles (Ct.) Sanitary Fibre Mills, Inc.

M. W. Alling, formerly overseer of dyeing at the Aspinook Co., Jewett City, Ct., has accepted the position of superintendent of the Bronx Company, New York City.

Arthur R. Layman, formerly at Dover, N. H., has accepted the position of overseer of spinning with the Puritan Mills, American Woolen Co., Plymouth, Mass.

Lewis D. Sands has accepted the position of overseer of dyeing at the Pembroke (Ont.) Woolen Mills, Ltd.

Alexander Reynolds, formerly employed at the Monticello (Ark.) Cotton Mill, has accepted the position of cloth overseer at the Lincoln Cotton Mill, Huntsville, Ala.

W. H. Thompson, overseer of weaving at the Fairfax (Ala.) Mills, is busy installing 150 additional automatic looms.

ANNOUNCEMENT.

Mr. Orlando F. Weber, president of the National Aniline & Chemical Company, Inc., announces the appointment of Mr. Robert T. Baldwin as assistant to the president, effective June 24th, 1919.



FOR SALE—All Size Flyers, Practically as Good as New, Polished Inside and Out at Bargain Prices.

Southern Spindle and Flyer Co., Inc.
CHARLOTTE, N. C.

Manufacturers, Overhauled and Repairers of Cotton Mill Machinery

W. H. Monty, Pres. & Treas. W. H. Hutchins, V.-Pres. & Sec'y

E. L. & Fred Sheridan
CONTRACTORS
Overhauling, Spinning, Twisting and Fly Frames
WINDER, GEORGIA

J. I. LAMBERT, Pres. J. R. GILBERT, Vice-Pres
 J. W. PARKS, Sec. & Treas.

The Novelty Wood Works, Inc.
 Manufacturers of
High Grade Hickory Picker Sticks
 SPEEDER AND SLUBBER BOBBINS, SKEWERS, CLEARER ROLLS AND LOOM BLOCKS OF ALL KINDS
RAMSEUR, N. C.

TURBINE WATER WHEELS
OF GUARANTEED EFFICIENCY

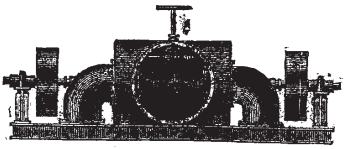

CYLINDER GATE, WICKET GATE, REGISTER GATE TURBINES, VERTICAL AND HORIZONTAL, SINGLE OR IN PAIRS.

ALSO, IMPULSE WATER WHEELS.
FOR PRICES AND CATALOGUES, Address

DAVIS FOUNDRY & MACHINE WORKS
ROME, GEORGIA

OETTER ELECTRIC CO.
Practical Electricians
 325 WALL STREET MACON, GA.
 Electric Motor and Generation Repairs
 Armatures and Coils Rewound
 Expert Troublemens

LOMBARD
Foundry, Machine, Boiler Works and Mill Supply House
AUGUSTA, : : GEORGIA

Capacity, 300 Hands
 Hundred Thousand Feet Floor Space

Cotton, Oil, Gira, Saw, Grist, Fertilizer, Cane, Shingle Mill Machinery Supplies and Repairs and Castings, Shafting, Pulleys, Hangers, Wood, Coal and Sawdust Grate Bars, Pumps, Pipe, Valves and Fittings, Injectors, Belling, Packing Hoses, etc. Cast every day. One hundred machines and good men ready to do your work quick.

TEXTILES

COTTON CLOTHS.

Reported by Louis Lowinson, cotton goods broker, 72 Leonard Street, New York.)

80/80 39" 4.00 plain cloths.....	26
72/76 39 4.25 "	22
68/72 39 4.75 "	20
64/64 38" 5.15 "	17½
64/60 38½ 5.35 "	17
64/56 38½ 5.50 "	16½
60/52 38½ 6.00 "	14¾
60/48 38½ 6.25 "	14¼
64/60 27 7.60 "	10¾
48/48 37" 4.00 Sheetings	16
56/60 36 4.00 "	17½
48/40 36 5.50 "	13½
48/48 40 2.85 "	22½
30" 3.25 Drills	21
30 3.00 "	22
37 3.50 "	21
37 3.95 "	19
80/80 40" 8.50 plain comb.....	26½
76/72 40 9.00 "	21
96/92 40 7.50 "	28
64/112 38 4.00 sateens	29
64/104 39 4.20 "	28

RAW COTTON.

Middling, June 26 34.95

COTTON YARNS EASTERN COMBED PEELER

10s	73-74
16s	76-77
20s	80
30s	91
40s	98-1.01

CARDER PEELER

10s	62
16s	64
20s	66
26s	70
30s	74
40s	79-81

MERCERIZED

2/40s	1.05-1.08
2/50s	1.20-1.40
2/60s	1.28-1.30
2/70s	1.50-1.52

SOUTHERN HOSIERY FRAME

10s 52-53

14s	55
20s	60
24s	62-63
30s	76-79
2/20s	41-43
2/10s	45-46

WARPS

2/10s	57-57
2/20s	66-68
2/24s	70-71
2/30s	78-80

DOMESTIC WOOL

Ohio and Pennsylvania Fleeces

Delaine washed	85-88
Fine unmerchanted delaine ...	82-85
XX	70-71
Delaine unwashed	80-82
Fine unwashed	61-62
½ blood combing	73-75
¾ blood combing	65-68
¼ blood combing	65-67
½, ¾, ¼ blood clothing	59-60
Common and braid	43-45

Southern Fleeces

Lake mediums	57-59
Georgia Mediums	58-60
Virginia, Kentucky and Similar	
½ blood unwashed	75-77
¾ blood unwashed	68-70
¼ blood unwashed	67-68
Common and Braid	44-45

SCOURED BASIS Texas

Fine 12 months	1.60
Fine 8 months	1.35-1.40
Fine fall	1.10-1.15

California

Northern	1.60
Middle County	1.40-1.50
Southern	1.30-1.35
Fall free	1.10-1.15
Fall defective	1.00-1.05

Oregon

Eastern No. 1 staple	1.68-1.72
Eastern clothing	1.40-1.45
Valley No. 1	1.55-1.58
Valley No. 2	1.22-1.25
Valley No. 3	1.03-1.05

Territory

Fine staple	1.75-1.80
½ blood combing	1.55-1.65
¾ blood combing	1.15-1.25
¼ blood combing	1.00-1.07
Common and braid	68-70
Fine clothing	1.40-1.45
Fine medium clothing	1.30-1.35

Pulled

AA	1.65-1.70
Extra	1.75-1.80
A supers	1.55-1.60
B supers	1.25-1.30
C supers	82-84
Fine combing	1.40-1.45
Medium combing	1.35-1.40
Coarse combing	1.00-1.05
California, finest	1.30-1.35
California, second	1.05-1.10

FOREIGN WOOL

SCOURED BASIS

Australian

Classes I and II	
Sydney 80s clothing	2.30-2.40
Sydney 70s average	2.25-2.30
Sydney 64s average	1.00-2.10
Geelong 70s	1.95-2.00
Geelong 64s	2.10-2.20
Geelong 60s	1.95-2.00

SCOURED BASIS

Cape

12 months	1.50-1.60
Short combing	1.40-1.45
Clothing	1.20-1.25

SCOURED BASIS

*New Zealand

Crossbreds	
36s to 40s.....	75-80
40s to 44s.....	85-90
46s	1.00-1.05
46s to 48s	1.05
50s	1.10
56s	1.25-1.30
58s	1.70-1.75

WORSTED YARNS

BRADFORD SPUN

2/20s ¼ blood	1.90 1.95
2/30s ¼ blood	1.85
2/32s ¾ blood	2.10-2.20
2/36s ¾ blood	2.60-2.75
2/40s ½ blood	3.20-3.45

FRENCH SPUN

1/20s ¼ blood	2.05-2.15
1/20s ¾ blood	2.25-2.30
1/30s ¾ blood	2.30-2.40
1/30s ½ blood	3.00

J. R. Tolar J. H. Hart	J. R. Tolar, Jr. P. G. Hart
TOLAR & HART	
Cotton Yarn and Cotton	
Members of New York Cotton Exchange	
322 Chestnut Street, PHILADELPHIA, PA. 49 Leonard Street, NEW YORK.	

WILLIAM WHITMAN CO., INC.,	
YARNS	
A wide and complete range suitable for all requirements	
Boston	New York
Phila.	Chicago

J. B. Jamieson	
77 Summer St., Boston	
COTTON YARNS	
of all descriptions Correspondence Solicited	

United States Conditioning & Testing Co.	
340 Hudson Street	220 Elison Street
New York, N. Y.	Paterson, N. J.
Cott's Wool and Silk Conditioning, Fabric Testing and Chemical Analyses	

A TapeBelt for Universal Winders

We have perfected a cotton tape belt for driving Universal Winders. Also one for Camless Winders. We urge all users of these machines to write us for samples. We offer this with our full indorsement because exhaustive tests have satisfied us of its real merit.

BARBER MFG. CO

Spinning Tape Specialists,
LOWELL, MASS.

DANA WARP MILLS

Westbrook, Me.

Cotton Yarns and Warps

WHITE and COLORED

HOSIERY BOARDS

QUALITY AND SERVICE

JOS. T. PEARSON
1825 E. Boston Ave., Philadelphia, Pa.

RIVERS & LEWIS

Contractors and Dealers in
Cotton Waste, Cotton Cloth, Cotton Yarns
Cheese Cloth Remnants
New Mill Ends
118 Borden St., FALL RIVER, MASS.

Fred Sternberg & Co.

530 BROADWAY, NEW YORK
MERCERIZED } **COTTON YARNS**
GASSED }
HARNES TWINES

HUGHES FAWCETT

115 and 117 Franklin St., New York
Linen Weaving and Knitting Yarns
Linen Jacquard Harness Twines
And Linen Yarns and Threads for
Every Purpose

Turkey Red Yarns

Large Stock Prompt Deliveries

1/50s-64s	3.40
2/40s 1/2 blood	3.30
2/50s 1/2 blood	3.60
2/70s Australian	3.20-3.30
FRENCH SPUN MERINO	
2/40s 1/2 blood	3.10-3.15
1/40-50-50	1.90-2.00
1/40-70-30	2.20-2.40
1/40-80-20	2.35-2.45

OLD WOOLEN RAGS.
GOVERNMENT MAXIMUM

Merinos	
Fine	34-35
Coarse light	19-20
Fine dark	19 1/2-20
Coarse dark	13-14
Fine black	18-19
Serges	
Light	32-34
Brown	42-46
Blue	42-46
Black	42-46
Red	42-46
Green	42-46
Flannels	
White (Fine)	55-60
Red	33-35
Blue	28-30
Knit	
White	46-47
Blue	21-22
Black trimmed	33-34
Red	23-24
Brown	27-28
Light gray	14 1/2-15
Light hoods	33-34
Mixed hoods	18-19
Silver gray	31-32
Skirted worsteds	
Light	18-19
Black	23 1/2-24
Blue	18 1/2-19 1/2
Dark	16-16 1/2
Brown	19-19 1/2
Skirted cloth	
Fine light	12-13
Light	10 1/2-11
Blue	8-8 1/2
Dark	6 1/2-7
Plain black	7-7 1/2
Skirted, tan cloth	23-24

It is announced that M. Truesdell, formerly connected with the General Asbestos & Rubber Co., will start a new asbestos yarn spinning mill at Charlotte, N. C.

Work will soon be started on alterations and additions to the mill of John W. West Thread Co., Columbia Road and Covington Street, South Boston.

The erection of an addition is contemplated to the Cherryville (N. C.) Manufacturing Co.

The Georgia Manufacturing Co., White Hall, Ga., are erecting a small addition to their present building to increase the floor space.

M. SALTER & SONS
WOOLEN RAGS

Our specialty is to grade woolen rags of every description ready for the picker. Write for samples and prices.
CHelsea, MASSACHUSETTS

B. COHEN & SONS
LARGEST GRADERS OF
New Woolen and Cotton Clippings
AND ALL KINDS OF REMNANTS

Write Us for Prices Before Shipping

OFFICE AND WAREHOUSES
Office 1244-46 So. Union Avenue
Old Rag Department, 1511 So. Sangamon St.
New Cotton Department, 757-759 W. Taylor St. } CHICAGO, ILL.

NEW AND RECLAIMED BURLAP

Suitable for baling knit goods and other textiles according to government requirements. Any quantity. Get our prices.

H. CUTLER & CO., 96-99 Second St., Chelsea, Mass.

ALL STEEL BALING PRESSES
ECONOMY FIRE PROOF
ALL SIZES FOR ALL PURPOSES
LARGEST LINE BUILT IN U.S.A.
ECONOMY BALER CO., DEPT. ANN ARBOR, MICH..U.S.A.

JENNISON CO. PIPERS FITCHBURG MASS.

Do You Want a Silent Partner?

One who gives advice but does not talk back.
He is the "Daily News Record!"

The Daily Newspaper of the Textile Trade
325-324 Broadway, New York
FILL OUT AND RETURN

Please let me know how the DAILY NEWS RECORD can be made to work for me.

Name

Business

Address

THE BRADLEY STENCIL MACHINE

Makes stencils in half a minute at reduced cost of 1-10 cent each

Write for prices and samples

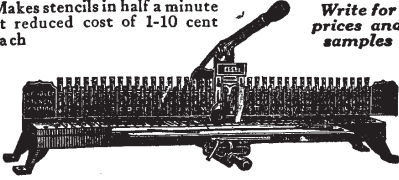

In Universal use by thousands of manufacturers and shippers
Manufacturers of Oil Stencil Board

A. J. BRADLEY, GEN. SALES AGENT
101 Beekman Street New York City, N. Y.

It Pays to Advertise in "Textiles" Because Progressive Mill Men Everywhere Are Its Readers.

WE-FU-GO AND SCAIFE

WATER PURIFICATION SYSTEMS
SOFTENING & FILTRATION
FOR BOILER FEED AND ALL INDUSTRIAL USES

WM. B. SCAIFE & SONS CO. PITTSBURGH, PA.

CLASSIFIED INDEX TO ADVERTISERS

Accountants and Engineers

Cosley & Marvin Co., Boston
 Ralph E. Loper, Fall River,
 Mass.

Air Moistening

Carrier Engineering Corpora-
 tion, New York.
 Parks-Cramer Co., Fitchburg,
 Mass.

Albans

Roessler & Hasslacher Chem-
 ical Co., New York.

Asbestos Machinery

Smith & Furbush Machine Co.,
 Philadelphia, Pa.

Automatic Feeds

(For cotton and wool)
 Smith & Furbush Machine Co.,
 Philadelphia, Pa.
 Philadelphia Drying Machinery
 Co., Philadelphia, Pa.

Balling Presses

Economy Baler Co., Ann Arbor,
 Mich.
 Philadelphia Drying Machinery
 Co., Philadelphia, Pa.
 Smith & Furbush Machine Co.,
 Philadelphia, Pa.

Ball Winding Machinery

Franklin Machinery Co., Prov-
 idence, R. I.

Bleaching

Home Bleach and Dye Works,
 Pawtucket, R. I.

Bleaching Kiers

Worcester Steam Boiler Works,
 Worcester, Mass.
 Philadelphia Drying Machinery
 Co., Philadelphia, Pa.

Bleaching Machinery

Delahunty Dyeing Machine Co.,
 Pittston, Pa.

Bleaching Materials

Roessler & Hasslacher Chem-
 ical Co., New York.

Bleaching Oil

Jacques Wolf & Co., Passaic,
 N. J.

Mowers and Blower Systems

Philadelphia Drying Machinery
 Co., Philadelphia, Pa.

Boilers

Worcester Steam Boiler Works,
 Worcester, Mass.

Boiler Feed Purifiers

Scaife & Sons Co., Wm. B.,
 Pittsburgh, Pa.

Boxes and Box Sheeks

Jos. T. Pearson, Philadelphia.

Braiding Machinery

Textile Machine Works, Read-
 ing, Pa.

Carbonizing Machinery

Philadelphia Drying Machinery
 Co., Philadelphia, Pa.

Chemicals

Hemingway, Frank, Inc., New
 York

Chrome Colors

Jacques Wolf & Co., Passaic,
 N. J.

Clipping Machines (shoe lace)

Franklin Machine Co., Prov-
 idence, R. I.

Cloth Cutting Machines

Eastman Machine Co., Buffalo
 Universal Cutter Co., St. Louis.

Cloth Testers

Scott, H. L. & Co., Providence,
 R. I.

Cloth Washers

Hunter, James, Machine Co.,
 No. Adams, Mass.
 Philadelphia Drying Machinery
 Co., Philadelphia, Pa.

Cones, Paper

Pairpont Corp., New Bedford,
 Mass.

Card Grinders

B. S. Roy & Son Co., Worces-
 ter, Mass.

Cop Skewers

Shambow Shuttle Co., Woon-
 socket, R. I.

Cotton Bat Heads

Franklin Machine Co., Prov-
 idence, R. I.

Cotton Machinery

Philadelphia Drying Machinery
 Co., Philadelphia.
 Smith & Furbush Machine Co.,
 Philadelphia.

Wildman Manufacturing Co.,
 Norristown, Pa.

Cotton Yarn Bleachers

Home Bleach & Dye Works,
 Pawtucket, R. I.

Cutting Machines

Eastman Machine Co., Buffalo.
 Universal Cutter Co., St. Louis.
 Wildman Mfg. Co., Norristown,
 Pa.

Drawing Frames (French Worst- ed)

Franklin Machine Co., Prov-
 idence, R. I.

Drying Machinery

Philadelphia Drying Machinery
 Co., Philadelphia.

Dusters

Smith & Furbush Machine Co.,
 Philadelphia.

Dyers, Bleachers and Finishers

Home Bleach and Dye Works,
 Pawtucket, R. I.
 National Silk Dyeing Co., Pat-
 terson, N. J.
 Providence Dye Works, Prov-
 idence, R. I.

Dyeing, Drying, Bleaching and Finishing Machinery

Delahunty Dyeing Machine Co.,
 Pittston, Pa.
 Philadelphia Drying Machinery
 Co., Philadelphia.

Dyestuffs and Chemicals

American Aniline Products,
 Boston.
 Atlantic Dyestuff Co.
 S. R. David & Co., Inc., Bos-
 ton, Mass.
 Du Pont de Nemours & Co.,
 Wilmington, Del.

Dye Exchange Corp., New
 York.

Hellenic Chemical & Color Co.,
 New York City.

Klipstein & Co., A., New York.

Metz & Co., H. A., New York.

Hemingway, Inc., Frank, New
 York.

Kohnstamm & Co., K., New
 York.

Levinstein, I., & Co., Inc.,
 Boston.

National Aniline & Chemical
 Co., New York.

Newport Chemical Works, Pas-
 saic, N. J.

Jacques Wolf & Co., Passaic,
 N. J.

Dyeing Temperature Regulators

Tagliabue Mfg. Co., C. J.,
 Brooklyn, N. Y.

Electrical Constructors

General Electric Co., Schene-
 cady, N. Y.

Electric Lamps

General Electric Co., Schene-
 cady, N. Y.
 Trop Specialties Co., New
 York.

Electric Motors

General Electric Co., Schene-
 cady, New York.

Engines

Franklin Machine Co., Prov-
 idence, R. I.

Export Publicity

Salades Export Publishing Co.,
 New York City.

Extractors, Logwood

Tolhurst Machine Works,
 Troy, N. Y.
 Worcester Steam Boiler
 Works, Worcester, Mass.

Feed Water Purifiers

Scaife & Sons Co., Wm. B.,
 Pittsburgh, Pa.

Flooring

Philadelphia Mineral Flooring
 Co., Philadelphia, Pa.

Flyers

Southern Spindle & Flyer Co.,
 Inc., Charlotte, N. C.

Fly Frames

Sheridan, E. L. & Fred, Win-
 der, Ga.

Flyer Pressers

Southern Spindle & Flyer Co.,
 Inc., Charlotte, N. C.

Felt Machinery

Smith & Furbush Machine Co.,
 Philadelphia.

Filters (Water)

Norwood Engineering Co.
 Scaife & Sons Co., Wm. B.,
 Pittsburgh, Pa.

Grinding Machinery

Roy & Son Co., B. S.

Gums

Jacques Wolf & Co., Passaic,
 N. J.

Hosiery Boards

Pearson, J. T., Philadelphia.
 Philadelphia Drying Machinery
 Co., Philadelphia.

Hosiery Machines

Brinton, H., Co., Philadelphia.
 Crane Manufacturing Co.,
 Lakeport, N. H.
 Nye & Treddick, Philadelphia.
 Textile Machine Works, Read-
 ing, Pa.

Wildman Manufacturing Co.,
 Norristown, Pa.

Humidifying Apparatus

Carrier Engineering Corp., New
 York.
 Parks-Cramer Co., Fitchburg,
 Mass.

Hydro-Extractors

Tolhurst Machine Works, Troy,
 N. Y.

Hydrometers

Tagliabue Mfg. Co., C. J.,
 Brooklyn, N. Y.

Iron Castings

Franklin Machine Co., Prov-
 idence, R. I.

Knitting Machinery

Brinton, H., Co., Philadelphia.
 Crane Manufacturing Co.,
 Lakeport, N. H.
 Huse & Sons, W. D., Laconia,
 N. H.

Hemphill Co., Pawtucket, R. I.
 Nye & Treddick, Philadelphia.

Stafford & Holt, Little Falls,
 N. Y.

Textile Machine Works, Read-
 ing, Pa.

Tompkins Bros. Co., Syracuse,
 N. Y.

Wildman Manufacturing Co.,
 Norristown, Pa.

Wildt & Co., Leicester, Eng.

Knitting Machinery, Full Fas-
 hioned

Textile Machine Works, Read-
 ing, Pa.

Knitting Needles, Etc.

Brinton, H., Co., Philadelphia.

Corey, William, Co., Manches-
 ter, N. H.

Laconia Needle Co., Laconia,
 N. H.

M. M. McCormick & Co., Phil-
 adelphia.

Mereerizing

Home Bleach & Dye Works,
 Pawtucket, R. I.

Manufacturers' Agents

Levey & Blankfield, New York.

Mill Supplies

Lombard Foundry & Mill Sup-
 ply House, Augusta, Ga.

Mordants

Jacques Wolf & Co., Passaic,
 N. J.

Oiling Machinery

Park Co., G. M., The, Fitch-
 burg, Mass.

Oils

Bradford Oil Co., Lynn, Mass.
 Swan & Finch Co., New York.

Overhaulers

Southern Spindle & Flyer Co.,
 Inc., Charlotte, N. Y.

Paints

Coolidge & Sons, Inc., F. J.,
 Augusta, Ga.

Paper Cones and Tubes

Pairpoint Corporation, New
 Bedford, Mass.

Peroxides

Roessler & Hasslacher Chem-
 ical Co., New York.

Pickers, Rag or Shoddy

Smith & Furbush Machine Co.,
 Philadelphia.

Pipers

Jennison Co., Fitchburg, Mass.

Pulleys

Franklin Machine Co., Prov-
 idence, R. I.

Recording Gauges

Tagliabue Mfg. Co., C. J.,
 Brooklyn, N. Y.

Recording Thermometers

Tagliabue Mfg. Co., C. J.,
 Brooklyn, N. Y.

Regulators for Temperature

Tagliabue Mfg. Co., C. J.,
 Brooklyn, N. Y.

Woolen Rags

Cohen & Sons, B., Chicago, Ill.

Rings, Spinning and Twister

Southern Spindle & Flyer Co.,
 Inc., Charlotte, N. C.

Rolls

Southern Spindle & Flyer Co.,
 Inc., Charlotte, N. C.

Schools

Lowell Textile School, Lowell,
 Mass.

New Bedford Textile School,
 New Bedford, Mass.

Second Hand Textile Machinery

John J. Healy, Newtonville
 Mass.

Lamb, J. K., Textile Machinery
 Co., Philadelphia.

Edward Jefferson, Philadelphia.

Shuttles

Shambow Shuttle Co., Woon-
 socket, R. I.

(Continued on following page)

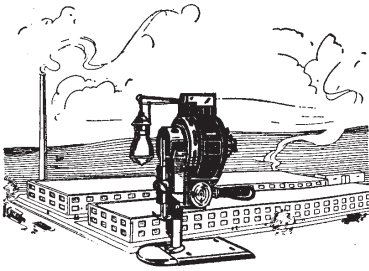

Investigate the equipment used in the big modern factories and there you will find many

EASTMAN GOLD MEDAL CUTTERS

giving perfect satisfaction. They are built for accuracy and durability.

"It's Best to Buy the Best First"

EASTMAN MACHINE CO., OF BUFFALO, U. S. A

NEW YORK 816 Broadway	PHILADELPHIA Heed Building, 1213 Filbert Street	ST. LOUIS 1420 Olive Street
BOSTON 87 Summer Street	DETROIT 119 E. Jefferson Avenue	SAN FRANCISCO 444 Market Street
CLEVELAND 1234 Superior Avenue, N. E.	CHICAGO 815 W. Van Buren Street	BALTIMORE 417 W. Baltimore Street
NEW ORLEANS, Godchaux Bldg.	HAMILTON, ONTARIO, 5 Sun Life Bldg.	

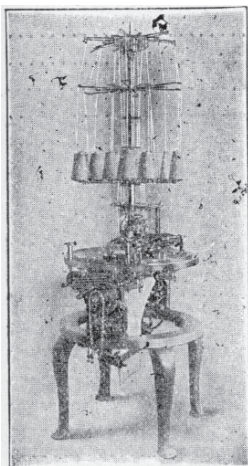

Sweater Machine

CIRCULAR SPRING and LATCH NEEDLE KNITTING MACHINERY

For the Manufacture of

Flat Wool and Cotton Underwear	Astrakhans
Balbriggan	Fur Cloths
Silk Skirts	Skirts and Toques with three color stripes
Fleece-Lined Fabrics	Sweaters with rack stitch, stripes and selvage edge
Jersey Cloth	

TOMPKINS BROS. CO., 583 South Clinton St.
ESTABLISHED 1846 SYRACUSE, N. Y.

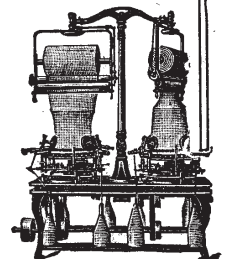

Spring Needle Machine

CLASSIFIED INDEX TO ADVERTISERS—(Continued from page 46)

- | | | | |
|--|--|---|---|
| <p>Silk Noils
Fawcett, Hughes, New York.</p> <p>Silks (Raw)
General Silk Importing Co., New York.</p> <p>Selling Agents for Mills
Clift & Goodrich, New York.</p> <p>Singeing Machines
Philadelphia Drying Machinery Co., Philadelphia.</p> <p>Soaps
Chemical Research Co., Denver, Col.
Electric Smelting and Aluminum Co., Lockport, N. Y.
Original Bradford Soap Works, Providence, R. I.
Warren Soap Mfg. Co., The, Boston, Mass.</p> <p>Special Textile Machinery
Franklin Machinery Co., Providence, R. I.</p> <p>Spindles
Southern Spindle & Flyer Co., Inc., Charlotte, N. C.</p> <p>Spun Silk Machinery
Franklin Machine Co., Providence, R. I.</p> <p>Stencil Machines
Bradley, A. J., New York.</p> <p>Tape Drives
Barber Mfg. Co., Lowell, Mass.</p> <p>Temperature Regulators
Carrier Engineering Corporation, New York.</p> <p>Tagliabue Mfg. Co., C. J., Brooklyn, N. Y.</p> | <p>Testing Apparatus
Scott, Henry L. & Co., Providence, R. I.</p> <p>Testing Establishments
U. S. Conditioning & Testing Co., New York.</p> <p>Thermometers
Tagliabue Mfg. Co., C. J., Brooklyn, N. Y.</p> <p>Transmission Machinery
Franklin Machine Co., Providence, R. I.
Hunter, James, Machine Co., North Adams, Mass.</p> <p>Tubes, Paper
Pairpoint Corp., New Bedford, Mass.</p> <p>Ventilating Apparatus
General Electric Co., Schenectady, N. Y.
Philadelphia Drying Machinery Co., Philadelphia.</p> <p>Waste Preparing Machinery
Smith & Furbush Machine Co., Philadelphia.</p> <p>Water Softeners
Scaife & Sons Co., Wm. B., Pittsburgh, Pa.</p> <p>Water Wheels
Davis Foundry and Machine Works, Rome, Ga.</p> <p>Winders
Payne, Geo. W., Co., Pawtucket, R. I.</p> <p>Wool Oil
Borne, Scrymser Co., Bradford Oil Co., Lynn, Mass.</p> | <p>Woolen and Worsted Machinery
Hunter, James, Machine Co., No. Adams, Mass.
Jefferson, Edward, Philadelphia.
Philadelphia Drying Machinery Co., Philadelphia.
Smith & Furbush Machine Co., Philadelphia.</p> <p>Yarn Dressers
Franklin Machine Co., Providence, R. I.</p> <p>Yarn Testers
Scott, H. L. & Co., Providence, R. I.</p> <p>YARNS, THREADS, ETC.
(Artificial silk)
Mindlin & Rosenman, New York.</p> <p>Cotton Yarn
Dana Warp Mills, Westbrook, Me.
Jamieson, James B., Boston.
Mindlin & Rosenman, New York.
Rivers & Lewis, Fall River, Mass.
Sternberg, Fred. & Co., New York.
Textile Yarn Agency, New York.
Tolar & Hart, New York.
Whitman, William, Co., New York.</p> <p>Glazed Yarns
Jamieson, James B., Boston.
Mindlin & Rosenman, New York.</p> | <p>Sternberg, Fred., & Co., New York.
Whitman, William, Co., New York.</p> <p>Linen, Hemp, Jute, Flax, Etc.
Fawcett, Hughes, New York.
Mindlin & Rosenman, New York.</p> <p>Mercerized Yarns
Jamieson, J. B., Boston.
Sternberg, Fred. & Co., New York.
Whitman, William, Co., New York.</p> <p>Merino Yarns
J. B. Jamieson, Boston.
Mindlin & Rosenman, New York.</p> <p>Silk Yarns
American Silk Spinning Co., Providence, R. I.
Cheney Bros., New York.
Textile Yarn Agency, New York.</p> <p>Woolen Yarns
Jamieson, James B., Boston.
Mindlin & Rosenman, New York.
Textile Yarn Agency, New York.</p> <p>Worsted Yarns
Mindlin & Rosenman, New York.
Textile Yarn Agency, New York.
Whitman, William, Co., New York.</p> |
|--|--|---|---|

In Writing Advertisers Kindly Mention "Textiles"

ALPHABETICAL INDEX TO ADVERTISERS

Allen, Wm., Sons Co.	7	Lombard Foundry & Mill Supply House.....	43
American Silk Spinning Co.	35	Long Co., R. H.	41
Atlantic Dyestuff Co.	8	Loper, Ralph E.	41
Barber Mfg. Co.	44	Lowell Textile School	40
Borne, Scrymser Co.	8	McCormick & Co., M. M.	41
Bradford Oil Co., Inc.	2	Merion Worsted Mills	35
Bradley, A. J. Mfg. Co.	45	Metz & Co., H. A.	32
Brinton, H. Co.	2	Mindlin & Rosenman	35
Carrier Engineering Corporation Front Cover		National Aniline & Chemical Co.....	31
Cheney Bros.	36	National Silk Dyeing Co.....	39
Clift & Goodrich	36	New Bedford Textile School	40
Cohen & Sons, B.	45	Newport Chemical Works, Inc.....	34
Cooley & Marvin Co. Front Cover		Norwood Engineering Co.	34
Corey Co., William	5	Novelty Wood Works, Inc., The	43
Crane Mfg. Co.....	42	Nye & Tredick Co.....	42
Crown Mills	41	Oetter, Rudolph	43
Cutler Co., H.	45	Original Bradford Soap Works	37
Daily News Record	38	Pairpoint Corporation, The	4
Dana Warp Mills.....	44	Parks-Cramer Co.	3
David & Co., Inc., S. R.	35	Payne Co., Geo. W.....	39
Davis Foundry and Machine Works	43	Pearson, Jos. T.....	44
Delahunty Dyeing Machine Co.	40	Philadelphia Drying Machinery Co.	9
Du Pont de Nemours & Co., E. I.	10	Phila. Mineral Flooring Co.	5
Dye Exchange Corporation	32	Providence Dye Works	33
Eastman Machine Co.	47	Rivers & Lewis.....	44
Economy Baler Co.	45	Roessler & Hasslacher Chemical Co.	35
Electric Smelting & Aluminum Co.	37	Roy & Son Co., B. S.	36
Farbwerke-Hoechst Co.	32	Salter & Sons, M.	45
Fawcett, Hughes	44	Scaife & Sons Co., Wm. B.	45
Franklin Machine Co.	40	Scott, Henry L., & Co.	38
General Electric Co. Back cover		Shambow Shuttle Co.	41
General Silk Importing Co. Front cover		Sheridan, E. L. & Fred	43
Healy, John J.	41	Smith & Furbush Machine Co. Front cover	
Hellenic Chemical & Color Co., Inc.	32	Southern Spindle & Flyer Co.	43
Hemphill Co.	6	Stafford & Holt Second cover	
Hotel Martinique	4	Sternberg, Fred & Co.	44
Hull, Canada, Town of	8	Tagliabue Mfg. Co., C. J.	1
Hunter, James, Machine Co. Third cover		Textile Machine Works Second cover	
Huse & Sons, W. D.	6	Tolar & Hart	44
Jamieson, J. B.	44	Tolhurst Machine Works	2
Jefferson, Edward Third cover		Tompkins Bros. Co.	47
Jennison Co.	45	United States Conditioning & Testing Co.....	44
Klipstein & Co., A.	33	Universal Cutter Co.	4
Laconia Needle Co.	36	Warren Soap Mfg. Co.....	39
Lamb, J. K., Textile Machinery Co.	41	Wernick, Harry C.	38
		Whitman, William Co., Inc.....	44
		Wildman Mfg. Co. Third cover	
		Wildt & Co.	40
		Wolf, Jacques & Co.	33
		Worcester Steam Boiler Works	7

In Writing Advertisers Kindly Mention "TEXTILES."