

The Weaver's Journal

\$2.50

JULY 1978

VOLUME III NUMBER 1

ISSUE 9

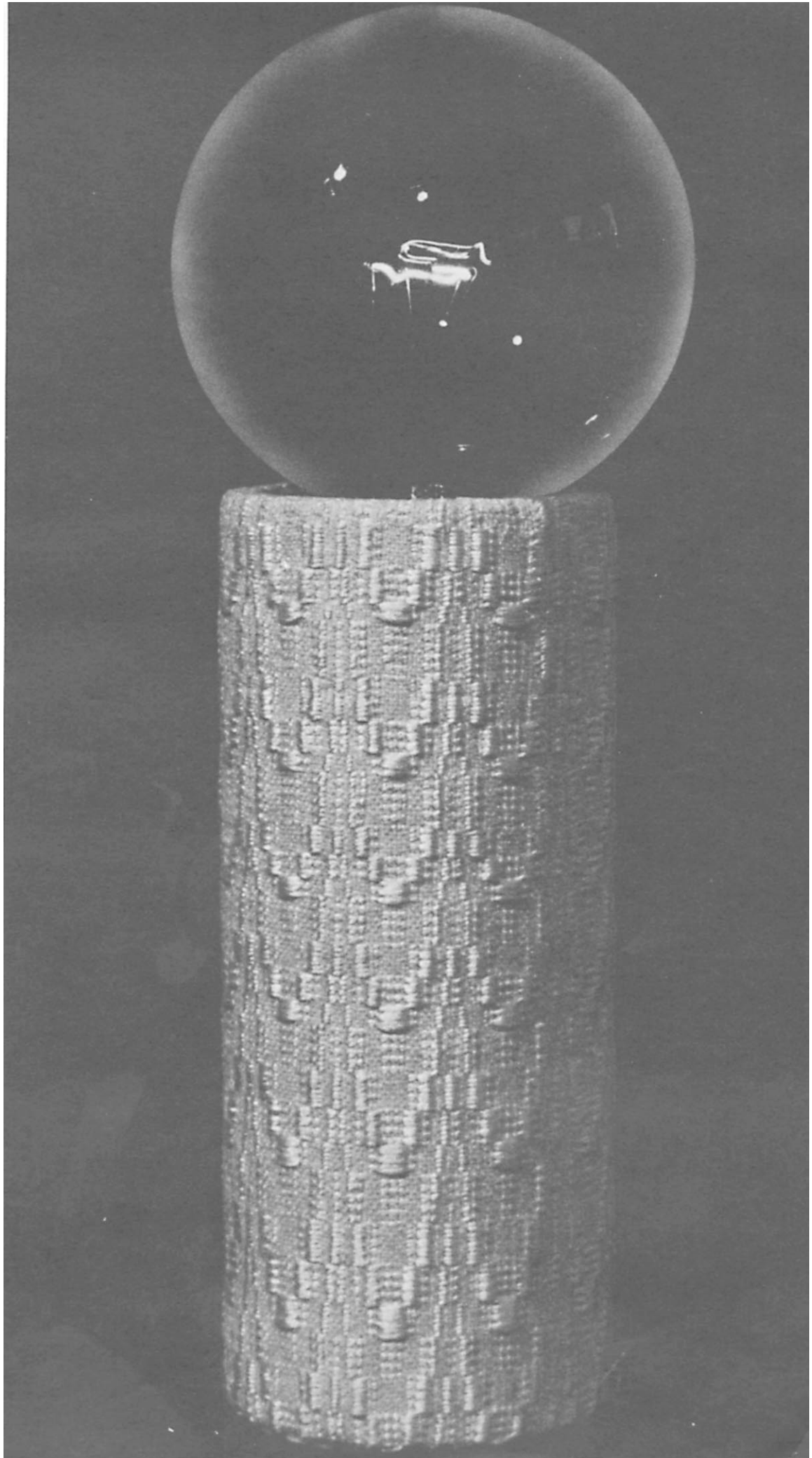

YARNS ONLY FROM FOLKLORICO

EL MOLINO FLOSS A 7-strand 100% rayon yarn made in Spain for Folklorico. Available in 39 colors and packaged 115 yards per tube. A beautiful and versatile yarn for many handwork uses. *Send \$1.00 for the color card.*

ROYAL MADRID GOLD AND SILVER Our new and incredible collection of threads, cords, purls, trims, tassels, soutaches, and more; in fine gold and sterling silver upon a base of copper wire. *Generous samples are available for \$6.00.*

THE ARTISAN COLLECTION FROM MEXICO Comprised of silk-like rayon acetate 8-strand floss (26 feet per skein) and 3 ply yarn (725 feet per skein); and our new heavy Rayon Perle (350 feet per skein). A range of 63 colors with more planned! *Send \$2.00 for the color card and generous samples.*

LA PALETA SILK-TWIST FROM SPAIN For fine needlework; 126 colors. Each small tube contains 32 feet of pure silk. *Send \$3.00 for generous samples.*

LA PALETA 6-STRAND COTTON FLOSS A tradition in Spain for generations. Offered in a rich palette. *Send \$5.00 for the color card and generous samples.*

LA PALETA MACHINE EMBROIDERY THREADS IN COTTON AND RAYON A wide range of colors, including many variegated. *Send \$3.00 for generous samples and the card showing 110 colors.*

100% WOOL YARNS Including our California-made "American Pioneer" offered in 7 dyed colors and 3 naturals. And our new "Green Mountain Wool" spun of 100% Vermont Virgin Wool in 4 natural colors. *Send \$1.00 for the set of wool color cards.*

*ALL THE ABOVE CARDS AND SAMPLES
ARE OFFERED AS A GROUP FOR \$15.00.*

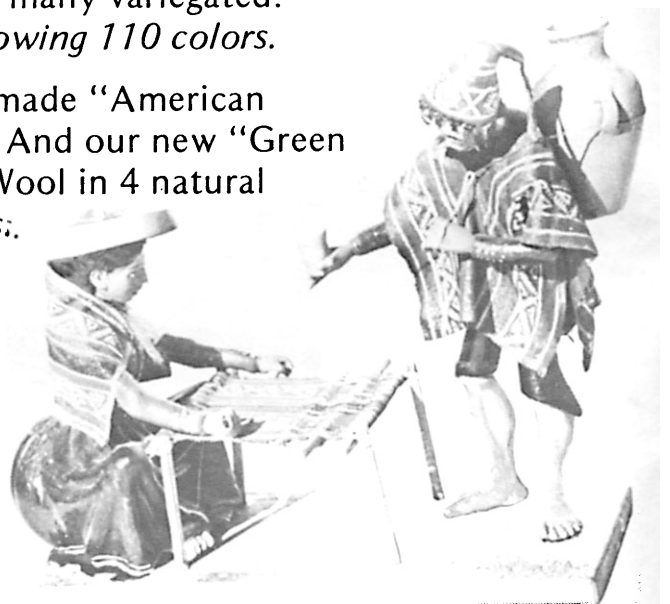

FOLKLORICO

522 Ramona Street • Dept. WJ • Post Office Box 625 Palo Alto, CA 94302

Our wholesale division invites inquiries.

(415) 327-6302

What Can You Do with These Low-Cost Greentree Yarns?



Textured Cotton 4-ply. Soft. Off-white. 168 yd/lb. \$2/lb
Textured Cotton 8-ply. Soft. Off-white. 84 yd/lb. \$2/lb
Soft-Spun Rayon 4-ply. White. 172 yd/lb. \$2/lb
Soft-Spun Rayon 8-ply. White. 86 yd/lb. \$2/lb
Jute, Thai. Many colors. 8-ply, 60-yd ball—\$1.75
 5-ply, 60-yd ball—\$1.50
Soft Cotton 2-ply. White. 320 yd/lb. \$2.50/lb
Rayon-Poly Blend. Thin; strong Trace dyed. 4800 yd/lb. \$2/lb
Jute, Thai. Natural. 10 lb/\$14 60-yd balls, colors. 45¢ ea.
Brushed Mohair. 3200 yd/lb. Dk Blue; mustard; lemon; yellow; loden green; jade; Nile; orange; fuschia. \$3/lb
French Wool Blend (55% wool) Tan or brown, flecked. Lb, 1600 yds. \$3
Soft-Spun Polyester, thick and thin. Warp or weft. 2000 yd lb. Blue; olive; tan; dk brown. \$3/lb
Rayon Loop. 3700 yd/lb. Orange; yellow; lt green; dk green; pink; lt blue; dk blue; purple. \$2.50/lb
Rayon Chenille; soft; white. 1350 yd/lb. \$2.50/lb
Rayon Slub. White. For warp or weft. 1000 yd/lb. \$3/lb

Beautiful weavings can come from these inexpensive yarns. Here are thick, thins, textures from \$1.50 to \$3 per pound. Quantities limited; please order early. Prices good thru April 30, 1978; for shipping and handling \$1 plus 10% of purchase. Min. order, \$5.

Greentree's Best Yarn Buy-- 10-lb. Bargain Bags, \$18 Ppd

Each bag contains a variety of yarns and colors. No two alike. All good quality. Price including shipping, \$18.

For Your Yarn and Equipment Needs, Look to Greentree

We are full line dealers for Leclerc, Schacht, Countryside, Greentree; also CUM yarns, Wollspinnerei, Berocco, and many others. Quantity discounts. Send SASE for list of sample cards, equipment, and prices.

Greentree Ranch



Wools



Department WJ-1 163 N. Carter Lake Rd.
Loveland, Colorado 80537 (303) 667-6183

The Weaver's Journal

Quarterly Journal For Textile Craftsmen
Volume III, Number 1, Issue 9

July, 1978

Table of Contents

Letter From the Editor.....	4
Fabrics for Interiors by Gail Rutter VanSlyke.....	5
Rugs Woven on Summer and Winter Threading.....	12
The Weaver's Market.....	19
Furniture in Coiled Basketry Technique.....	22
A Reversible Jacket in Double Weave by Jane Evans.....	23
Instructions for Weaving a Bog Shirt by Barbara Kinahan.....	26
Corded Weaves: Four Harness Cords for Upholstery Fabric, Drapery Material and Wallhangings.....	28
Wool Finishing by Francis Mayer.....	31
Roman Shades and Bedspread.....	32
Book Reviews.....	35
Andean Crossed-Warp Techniques for Decorative Trims, Part II - Tubular Bands.....	38
Woven Swing.....	46
List of Advertisers.....	47

Editor and Publisher - Clotilde Barrett
 Associate Editors - Mary Derr and Maxine Wendler
 Copy Editor - Earl Barrett
 Staff Artist - Ellen Champion
 Advertising Manager - Jeanne Richards
 Circulation Manager - Iris Richards
 Promotion Director - Willy Bottema
 Photography - Earl Barrett

The Weaver's Journal is published on the first of each January, April, July and October at 1900 55th Street, Boulder, Colorado 80301. Telephone (303) 449-1170. Subscription rates are \$9.50 U.S. Currency, for 1 year (4 issues) or \$17.50 U.S. Currency, for 2 years (8 issues). (Colorado residents add 3½% sales tax). Outside U.S.A. 1 year \$11.50 U.S. Currency, for 2 years \$20.00 U.S. Currency. Copyright Colorado Fiber Center, Inc. 1978. Second class postage paid at Boulder, Colorado 80302.

The editorial committee takes no responsibility for the goods advertised in this journal.

Cover Photo: Mood Lamp designed and woven by Iris Richards. Instructions in next issue of *The Weaver's Journal*.

WORKSHOPS AND LECTURES

Clotilde Barrett, editor/publisher of *The Weaver's Journal*, will travel and give workshops and/or lecture.

Some of the favorite subjects are:

- Shadow Weave
- Doup Leno
- Rug Techniques
- Loom Controlled Designs
- Summer and Winter

For further information, write to *The Weaver's Journal*, 1900 55th Street, Boulder, Colorado 80301. Telephone (303) 449-1170.

Letter From the Editor

With this issue we are starting our third year of publishing *The Weaver's Journal*. More than ever we try to stick with our commitment of providing our readers with ideas and instructions. Some articles are mostly meant to be reference material, helping the weaver to put certain weave structures in the right perspective even if they may require more harnesses than most people care to work with. We will continue to publish in-depth studies of textile techniques as, for instance, the Bolivian crossed warp bands. We especially like to publish loom and non-loom techniques which are not widely found in text books, or we might suggest a new approach to a weave that is well known. We like to describe projects which will stimulate the craftsman by giving new ideas. We try to help the beginning weaver by giving detailed instructions and describing projects that are easy and very rewarding.

We do research on fiber, spinning, and dyeing and like to share our results with our readers. We are also planning articles on tools and equipment for the "do-it-yourself" weaver and would appreciate information from everyone who wants to tell us about their own experiences in making or improving weaving and spinning tools.

From the response that we get from our readers, we are sure that we are filling a need that is not met by any other textile publication. Our promise is to fill that need with a scholarly and creative approach.

THE WEAVER'S WAY ALTERNATIVE

Verel Handweaving Yarn

Dealer Inquiries
Invited

Not a substitute for natural fibers — an ALTERNATIVE IN 5/2 cotton count
Ask for Verel at your local weaving shop or send SASE for free sample card

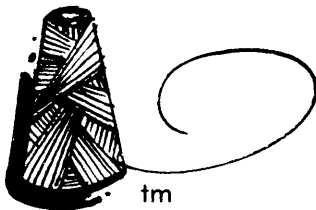

WEAVER'S WAY

306 E. Goldsboro Street
Crown Point, Indiana 46307

A complete handweaving shop with most models of Leclerc looms on display
Beginning weaving workshops offered quarterly

YOU CAN STILL ORDER WEAVING AND ANY OTHER BOOKS BY MAIL

But if you're coming to CONVERGENCE, we'll hope to see you
in our big BOOK BOOTH, Room 230, near the North Ballroom.
There'll be all the good books you've heard of—and MORE!

KATHERINE RAMUS 2100 E. EASTMAN AVE. ENGLEWOOD, COLORADO 80110
Phone 303-789-3115

Fabrics for Interiors

by Gail Rutter VanSlyke

Introduction

How often do you think of fabrics in an interior as making people feel secure, related, alive? Without fabric, today's sterile interiors are only bare-bone shelters due to modern day construction trends. Nineteenth and older twentieth century houses had much more character than do buildings of today, due to the use of materials and the ornate construction vogue of that era. Today, it isn't the interior architecture but the furnishings which differentiate interior spaces and give them a sense of materials and identity.

Fabric, of all the furnishing components available, is probably the major contributor to making an interior space particular. It is versatile, easily handled, economical, and comes in unlimited varieties.

The performance of fabric used in interiors is related to exposure, climate, fabrication, maintenance, and abuse. In selecting utilitarian fabrics one should not throw caution to the wind, but a safe solution isn't always the best solution either. For example, to select institutional fabric for residential use is about as questionable as the reverse.

In any case, the prime requisite of an interior fabric is that it contribute toward making environmental spaces alive and particular, with a happy balance between aesthetic, personal, and practical considerations.

Whether selecting or weaving a single fabric to be used alone or in conjunction with other interior fabrics, or creating an entire fabric system, it is essential to establish concepts. Concepts are ideas, both non-tangible and physical characteristics (elements of design) such as: a specific structure (*e.g.* a ribbed weave); a motif of pattern (a square); a specific color scheme (a gradation); and specific yarns can be elements of interest from one fabric to the next and thus contribute to the total design. Non-tangible ideas usually involve knowing oneself in relation to one's work and personal interests. Design concepts are most often in a state of flux with regard to their placement on the scale of importance.

The importance of having specific conceptual concerns is that it yields a consistency in one's work, a logical progression in exploration, and better design. When this process is applied to designing interior fabric systems, the result is a successful system in which all fabrics work together.

Here I must stress the idea of having fabrics of a given interior being integrally related to one another and to other features of the area, so as to produce a cohesive whole. For example, if one were asked to weave a fabric for a certain piece of furniture in a room, one should keep in mind the attitude and feeling of the room (contemporary, antique, etc.), and the surrounding textures, patterns, and colors of not only other fabrics but of other pertinent surfaces. Likewise, when designing all the fabrics for a specific area, the fabrics should relate to each other and also to architectural features and furniture.

Fabrics in relation to color, texture, and pattern

Fabric is the principal device for introducing and changing color, texture, and pattern into an interior. It has enormous decorative potential. Due to easy manipulation, storing, and rotating, fabric schemes can be changed seasonally and for special occasions via slipcovers, window coverings, wall decor, and rugs, just to mention a few examples.

Because of the infinite possibilities of using color in a fabric, especially when one is able to weave one's own, selected adjacent colors can be of very high contrast, or can simulate "natural" color through low contrast or through broken or fragmented colors. Ikating and dip-dyeing are two methods to achieve broken or fragmented color. Compared with today's rather impersonal building materials, broken color, easily produced in fabrics, is a visual high point.

Not only through color does fabric create interest, but also through texture. Texture of fabric in an interior can break the monotony of slick, cold, building materials as metal, plastic, and glass. Cloth has both visual and tactile texture: visual resulting from the play of light and shadow upon the surface, and tactile because the actual relief of the surface can be felt when touched.

Texture should not be confused with pattern. Pattern is the visual configuration of the cloth. A motif is a pattern repeat or a unit that is a part of a complex pattern. Pattern enriches an area, adds variety to surface, fills or breaks up space, orchestrates a color scheme, and can establish directional lines or movement.

The three elements, color, texture, and pattern, compose the design of the fabric. When working with fabric for an interior, it is important to consider these three prevailing elements in relation to other interior elements. For example, light will have a great effect on color and texture. One should try to determine the final color scheme on the spot in both natural and artificial light. Concerning texture and light, one should realize such facts as that higher texture can exist in rooms with directionless light or in large rooms with almost any type light.

Pattern, in relation to interior elements, should be inversely proportional to the amount of furniture or space-filling objects in a room. Busy places, such as offices, need less pattern and texture. These situations benefit from pattern on a grandiose scale or great sweep so as not to compete with machines and activities. In living rooms used for a variety of functions and for quiet hours, soft-edged and low contrast patterns are desirable. In rooms where art is to be displayed, the relationship between the art and the patterns in the room is delicate. Generally, pattern and texture should be kept to a minimum in a gallery space, but sometimes works of art can be enhanced by structured, rhythmically regular surfaces such as parquet floors or patterns with low relief.

The average apartment or suburban dwelling which is barren and featureless lends itself to enrichment via patterned and textured fabrics. The psychological demand for pattern is less in modern buildings with open floor plans characterized by glimpses into other rooms and landscapes.

A most interesting subject, when working with interior fabric, is that of the psychological involvement of the occupants with the textiles of their environment. For example, in the rural environments where houses are isolated and

where people are often engaged in battling the elements of nature, they want cozy houses which protect them from the outdoor conditions, and which are stimulating and reassuring. One of the ways to achieve this feeling is by use of fabrics with busy, rhythmic patterns. Today's urban environment is hectic, busy; neighbors are too close, and many times one gets the feeling of being in a concrete jungle. Because of this type of lifestyle, contemporary interior environments are preferably quiet and serene, and textured surfaces of interior fabrics can offer relief to the psyche from city noise.

Casements

A casement is a fabric which lets light through in an interesting or unusual way. In today's overcrowded world, we feel a need for a sense of privacy; a light, airy casement fabric can provide this privacy without sacrificing "borrowed" outdoor space or sunlight. Current day trends in architecture put quite a demand upon casements due to the large amount of glass which is used. Casements can soften the hard lines of a city view as well as function to control light.

When thinking of fabric as a window treatment, one must consider many aspects; most importantly the view and light control. Concerning the view, one should design a casement keeping in mind the position of the fabric throughout the day and night. Will it be only open or only closed both day and night, or open day and closed night, or the opposite? If the fabric is to eliminate the dark void of a night view, the fabric would be best in a light color or one similar to the wall coloring. But if a city view of lights is available at night and yet a sense of privacy is preferred, a large open mesh fabric will provide for both desires and also cut the glare of daytime sun.

Light control is a primary function of a casement. Glare, aggressively dominating directional light, can offend the psyche, weary the body and the mind, and shorten the temper. Sharpened by the high contrast of its own shadows, glare destroys interior composition, especially color. The demand upon casement fabrics is not only to reduce glare, but to admit or exclude light, and possibly even color light at the same time.

The color of the casement itself is important. A dark value, open mesh fabric is best for reducing glare but also increases visibility. This type of casement is effective in areas facing sand, snow, and water. With a city view of gray, it is better to use a white fabric. Colors of casements can lend their tints to interiors. In an area where skies are gray or white, a yellow, gold, or orange casement can give the illusion of sunlight. Psychological relief from the chill of winter can be obtained by using a red, rose, or flame colored fabric. Relief from the heat of summer can be accomplished with pale green and blue tints from the window covering.

Casements for reasons of camouflage can be very effective in architectural correction or unification where irregular or poorly proportioned windows can be masked, lengthened, or widened. Interior clutter such as radiators, beams, and air conditioners can be screened. Fabric solutions are relatively immediate in application, less arduous, less expensive, and often less phony than structural alterations. And fabric solutions are reversible.

Technically speaking, dimensional stability (shape retention) is a prime requirement for any fabric that hangs freely. The noticeable changes that will occur in a fabric that hangs will be in length and are caused by sagging, shrinking, or hiking (an alternation of the two). Heavy, loosely constructed fabrics are more prone to sagging than tightly woven ones. The weight of the horizontal

element in a woven fabric (the filling or weft), is a prime factor in stability; a balanced cloth or one with a heavier warp than filling will be more stable than one with a heavier filling than warp. In fact, a fabric constructed with fine warp and heavy filling is extremely susceptible to every variation of dimensional instability.

Cleaning a handwoven casement fabric can be done by gentle hand washing if the yarn has been prepared properly before weaving and if the panels are not so big that they can be lifted when wet. To prepare yarn properly it should be washed or dyed *before* weaving, in skeins or warp chains. This not only cleans the yarn and pre-shrinks it, but also increases the loft. Washing and pre-shrinking minimizes unexpected effects when the fabric is woven and then washed. When weaving an open fabric such as a casement, it is especially important to wash yarns before weaving because if the fibers are washed for the first time when they are in a woven state, the loft of the yarn might increase so much as to close up the openings in the fabric. Also, if more than one type of yarn is used, the yarns might shrink different amounts and a seersucker effect or scalloped edge might result.

Sun rot, the disintegration of fabric in sunlight from both heat and light, is the major problem with casement fabrics and usually not discernible until the fabric is dismantled for cleaning. Mineral fibers, such as fiberglass, are the only fibers not susceptible to sun rot. Silk, sheer cotton, most rayons, and nylon are highly susceptible. Acrylics, polyester, linen, and acetate are superior in resistance. The fiber alone is not the only criterion for determining resistance to the sun's effects. Weight and balance of the cloth and the size of the yarn particularly the warp, affect the degree of resistance.

Slip resistance (warp and/or filling yarns slipping to distort the design of the cloth) is controlled by using weaving techniques that offer resistance to slipping in open weaves: leno, mock leno, doup leno. Also, highly textured yarns will retain placement better than slick yarns.

Upholstery

The success of upholstery depends upon the relationship of the fabric to the character of the piece of furniture. The more complex a furniture form, the narrower the range of fabric that will work well with it. For example, an easy, formless sofa may accept a wide variety of textures, color, and patterns. A well-defined chair with exposed wood and strong lines limits the choice of fabric. Furniture with a strong silhouette is actually sculpture, and upholstery should affirm and emphasize form, not camouflage it.

Upholstery can be a great modifier of furniture design. Often it determines style and character, scale, and importance of a piece of furniture. A very basic chair could be appropriate for many settings, the settings being determined by the upholstery. For example, a chair upholstered in chintz might be suitable for a bedroom, one done in a wool tweed for a study or den, and one finished in leather or white fabric for executive office use. In addition to the type of upholstery, the upholstering technique may affect the character of a chair. The bedroom chair in chintz could be skirted and extra stuffing added, the study chair weltless and buttoned, the chair in the executive office channeled and top stitched.

The prime requirement for upholstery, both visual and tactile, is flatness.

Furniture itself has form and therefore requires a fabric with little movement and dimension (static). Dimensional depth within the fabric pattern destroys furniture form and creates a busy camouflage. Patterns which are tricky to work with or that should be avoided are: unbalanced diagonals, spiral movements, circular motifs, and large dark forms on a light ground (or the opposite). An example of this kind of pattern would be a large houndstooth pattern. When used as an upholstery, it can create a very uncomfortable situation. It can even discourage someone from sitting on the piece of furniture it covers; the person wonders if the design may even poke him when he sits on it! Likewise, when a large black and white houndstooth is the pattern for a carpet, it can give the feeling that one might fall through the white areas to the voids and depths illusioned by the black areas.

The scale of fabric should be relative to the space it occupies, both in pattern and texture. Large patterns and highly textured fabrics are best utilized on large pieces of furniture and in big rooms; small patterns and low textures on small delicate pieces of furniture and in small areas. The appropriateness of upholstery and decorative fabric can encourage and discourage the use of a piece of furniture or a room. For example, there is a current trend toward the use of a lot of white in interior decorating. In some situations, white can be very effective; for example, in an executive suite where white upholstery discourages all but the most important from using it. It connotes executive importance. But white decor in a residence, especially where there is an active and/or large family, is totally impractical. It will either discourage use of the room for daily living because of the soil factor, or will continually have to be cleaned.

There is a tendency today to have fairly neutral, easy-care upholstery fabric which is not too rough or overly slippery, neither pleasant nor unpleasant. It is unfortunate that tactile sensuous pleasure today is a luxury. Weavers have more choices than most people to acquire the type of fabric that appeals to them or their clients. Certain combinations of yarns and weaves can produce fabrics very pleasant to the touch; for example, ribbed and corded fabrics.

For comfort's sake, one must keep in mind the intended use of furniture and rooms, especially the amount of hours to be spent therein, and the climatic conditions of the environment. Prickly, harsh fabrics on furniture where one must sit long hours or in humid climates can cause tense and hostile feelings for the occupants.

Resistance to abrasion is the most essential durability factor but cannot be considered alone. However, if one does not stress durability alone one can have a wider range of more textures, aesthetically stimulating fabrics from which to choose.

Durability of upholstery fabric is the sum total of many physical qualities. Abrasion resistance is related to form and construction of furniture, yarn used in construction of fabric, and the amount and type of use. Wear, in relation to the tautness of the fabric, will be more likely to occur the tighter the fabric is stretched. For reasons of comfort and fabric life, when selecting or weaving upholstery fabric, keep in mind how the frame is padded and cushioned, finished and welted, and the degree of tautness. The prime abrasion points on a piece of upholstered furniture are the arm, top front edge of the seat, and any raised points such as welts. Be sure to ask yourself if your fabric will hold up to the possible wear in these places.

Again, a fabric's resistance to abrasion is affected by many factors: type and quality of fiber, size, twist and ply of yarn, and density of the weave. Tightly twisted and plied yarns provide a strong surface because each ply within the yarn strand is protected by the overlapping of the following ply. Close-set weaves also provide a resistant surface because individual yarns are protected by the unified surface of a cohesive weave. The weight and thickness of fabric is also a factor in abrasion resistance. The built-in cushioning resilience of a thick, soft fabric yields durability, and the tensile strength of the fiber is obviously important to the durability of the entire fabric.

Dimensional stability, or shape retention ability (resilience) of upholstery fabric is a major concern. Fabric must be able to shrink back to normal contour after the occupant leaves. It shouldn't buckle, sag, or wrinkle; these are undesirable qualities caused by stretching of the actual fabric or deformation of the undercushioning. Keep in mind the resilience of the undercushioning as well as that of the upholstery. Modern day trends toward unbuttoned, slab cushions and sculptured shapes require upholstery fabric to be very resilient because outlines must be maintained without reinforcement. Fabrics lacking in resilience or stability should be supported by buttoning, channelling, or tufting.

Slippage in fabric (where yarns slide out of place) is undesirable in upholstery and makes the fabric subject to rapid destruction and abrasion. Slippery yarns and unbalanced fabric constructions should be used minimally. To avoid seam slippage and raveling (where yarns pull away from stitched seams), several procedures can be followed: 1) fabrics can be backed, 2) allow ample width for seams (which will depend upon the fabric), 3) machine stitch a double row of machine stitching, and 5) reinforce seams by stitching muslin to seam areas.

There are many factors concerned in selecting appropriate upholstery fabric. The final choice, as far as the life expectancy is concerned, should probably be based upon the sense of life of the fabric and its responsiveness to cleaning.

Floor Coverings

Many of the properties that yield good upholstery fabric can also apply to rugs and carpets. A low abrasive texture and darker color are appropriate qualities to have in a floor covering where there is a heavy traffic pattern. Already discussed are the ramifications of using bold patterns such as the high contrast houndstooth. Tightly woven structures and weaves producing thick fabrics will be most durable.

The abovementioned technicalities are concerned mainly with utilitarian floor coverings. Another area of interest is the floor covering fitting more into the category of the art fabric. An area rug, used under a glass coffee table or in a conversation area surrounded by chairs where there is little or no traffic, can generally possess any texture, pattern, or color combination because it is mainly decorative. It can be used to bring out those characteristics appearing in other fabric in the room which might be of a subdued character to fit the requirements of utilitarian fabrics. For example, if a ribbed upholstery fabric is used, the ribbed effect might be echoed in higher relief in a non-utilitarian rug (or art fabric elsewhere in the room such as on the wall) to emphasize the ribbed surface and give it the illusion of more texture when in fact it is relatively low relief and very suitable for the durability requirements of upholstery. The art fabric can be the high point of an interior

fabric system and can coordinate the effects of the other fabrics in the room so that they do produce an integral and cohesive combination.

On walls and as walls

Whereas fabric is the universal covering for windows and furniture, it was unusual until recently to find it on walls. The more frequent appearance of fabric on walls today is the result of architecture which lends itself to the application of fiber on walls, and to the physical and psychic need for relief from sterile walls. As mentioned earlier, contemporary interiors need texture, pattern, and color. Part of the purpose of fabric on walls or as walls is to reinforce, compensate, supplement, or enhance minimal architectural materials.

If fabric is used as a wall covering it will usually be a large area. The size of the area in relation to the texture, pattern, and color of the fabric must be kept in mind. The fabric should not overwhelm the occupant of the space if he will spend a substantial amount of time there. For example, in a waiting room, a wall fabric should be more subdued than a fabric would have to be in a hallway or other transient area, where no one would be spending a great deal of time. The range of fabric textures available offers a broad choice of easily-applied aesthetic effects. Here again, weavers have a tremendous advantage in choices by being able to create their own.

Using fabric on walls can also be an economic and effective means of covering up damages to walls and improving the acoustics of the space. Fabric is a very successful sound-absorbing material and the psychological effect of quiet is intimacy, remoteness, and serenity.

Fabric, with its warmth and suppleness, brings a softness to the interior which it encloses that is physically and psychologically satisfying. In addition to a sensuous, tactile quality of a fabric wall, the wall has a gentle give (a "yielding") to it, the opposite of the rigid, forbidding hardness of common wall surfaces.



NOW AVAILABLE!

<i>Jacob Angstadt</i> <i>His Weaver's Pattern Book</i>	<i>Jacob Angstadt Designs</i> <i>Drawn from</i> <i>His Weaver's Pattern Book</i>
---	--

TWO NEW BOOKS REVEAL 18th CENTURY MASTER WEAVER'S RECORDS
A photographic replica of Jacob Angstadt's patterns; 307 coverlet & tablecloth drafts; 237 tie-ups for point twill drafts on 6, 8, 12, 16, 20, 24, 28 and 32 shafts. Companion book contains nearly 500 drawdowns from the profile drafts and point twill tie-ups. Designs adaptable to unit weaves on 8 and 10 shafts. Prepared by Ruth N. Holroyd with Ulrike L. Beck. 8 1/2 x 11" Hardbound Set totaling 400 pages.

Published & Distributed by:
Ruth N. Holroyd
20 Old Farm Circle
Pittsford, N.Y. 14534 U.S.A.

\$39.95 per Set* plus \$1.25 Postage & Packaging
*N.Y. State Residents add 7% tax. Dealer Inquiries invited.

For a workshop in "Playing with Profiles", interchanging weave systems within these multi-harness profiles, write Ruth Holroyd

The Weaver's Journal

SHOP OWNERS

To sell single issues of "The Weaver's Journal" write to:

"The Weaver's Journal"
1900 55th Street
Boulder, CO 80301

Rugs Woven on Summer and Winter Threading

The Summer and Winter system lends itself well to rugs with bold designs made of large block patterns. However, smaller colorful patterns can be created on some special threadings. None of the rugs described in this article uses tabby; thus they use a different treadling than the Summer and Winter weaves described in Part I of this article. (*The Weaver's Journal* Vol. II, #4, pp 28-35)

Four Harness Summer and Winter Rugs

Plates 1 and 2 illustrate rugs woven on the same warp.

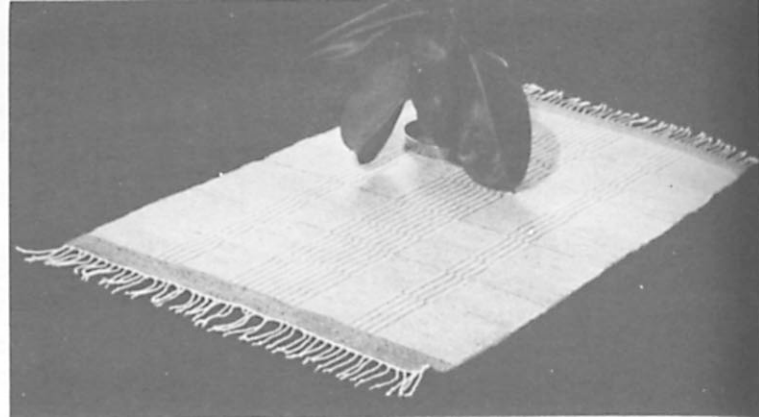
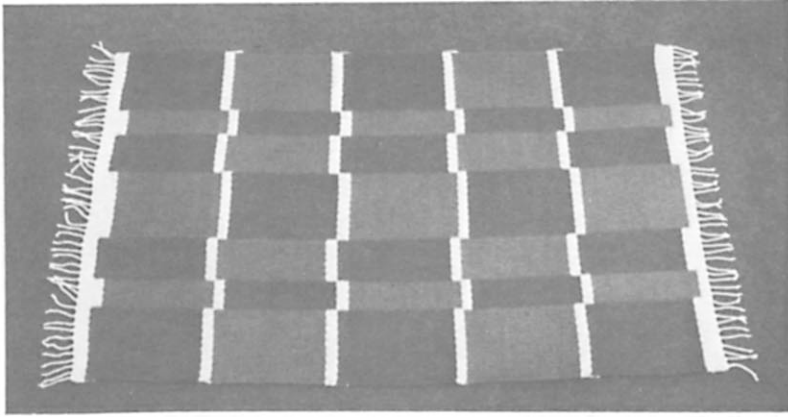

Plate 1

Plate 2

Two Summer and Winter Rugs designed and woven by Jeanne Richards

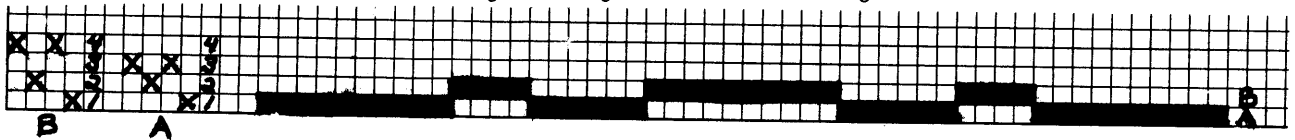

Fig. 1

Fig. 1 shows the profile draft and the unit threading for these rugs.

WARP: frieze wool (2- 2ply overspun wool)

WIDTH IN THE REED: 40" (103 cm).

SETT: 5 e.p.i. (20/10 cm).

SLEY AND SELVEDGE: double the two outer warp ends in the heddle and the reed. Use a floating selvedge (see *The Weaver's Journal* Vol. II No. 2 p. 17).

TOTAL NUMBER OF WORKING ENDS: 200.

As each unit of Summer and Winter requires 4 ends, we had 50 units (squares of the graph paper) on which the profile draft had to be designed. The block changes and the proportions of the block had to be adjusted accordingly.

Summer and Winter rugs are woven on opposites. That means that each pick woven with weft A is followed by a pick in the opposite shed woven with weft B.

Description of Rug I Fig. 2:

WEFT: W - white 3 ply rug wool, Henry's Attic.

R - rust } 4 ply rug wool, Raye's Eclectic.
G - gold }

TREADLING:

Section I lift H1-3 weave W
H2-4 weave W
H2-3 weave W
H1-4 weave W

Section II lift H1-3 weave R
H2-4 weave W
H2-3 weave R
H1-4 weave W

Section III lift H1-3 weave R
H2-4 weave G
H2-3 weave R
H1-4 weave G
etc.

Description of Rug II

Rug II combines blocks of weftway stripes and pick and pick such as in section IX of Fig. 3.

W - white single New Zealand wool,
G - grey Ironstone Warehouse.

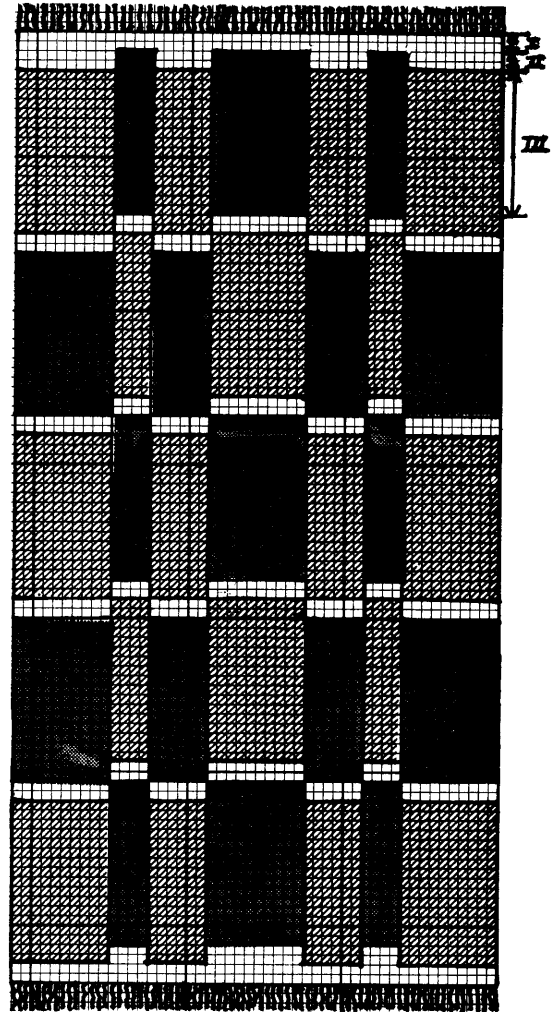

Fig. 2

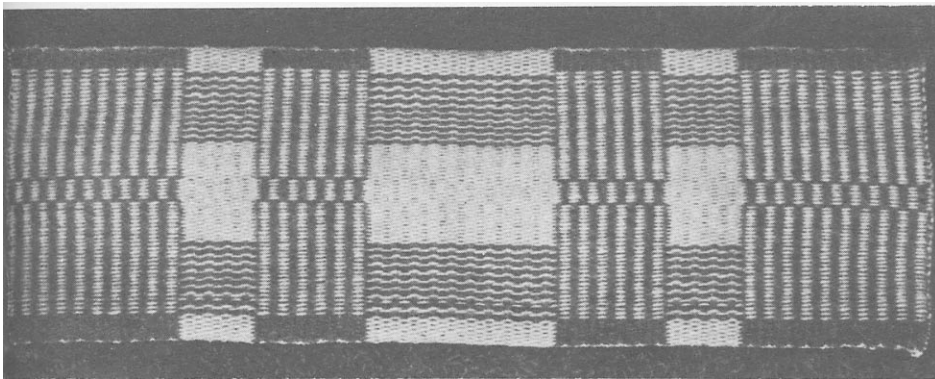

Plate 3 - Sample of 4H Summer and Winter Rug

Plate 3 shows a rug sampler which was woven on the same warp as rugs I and II. It illustrates part A of Fig. 3 and combines solid blocks with striped ones.

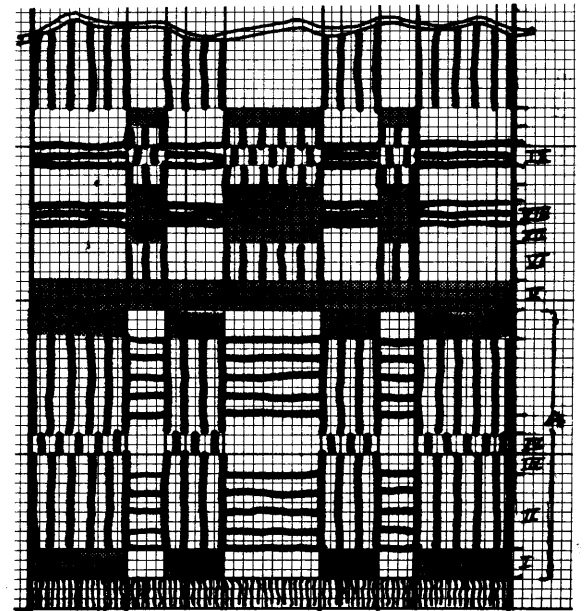

Fig. 3

TREADLING FOR FIG. 3

Section I
 lift H1-3 weave W
 H2-4 weave G
 H2-3 weave W
 H1-4 weave G

Section II
 lift H1-3 weave G
 H2-4 weave G
 H2-3 weave G
 H1-4 weave W
 H1-3 weave W
 H2-4 weave G
 H2-3 weave W
 H1-4 weave W

Section III
 lift H1-3 weave W
 H2-4 weave G
 H2-3 weave W
 H1-4 weave W

Section IV
 lift H1-3 weave W
 H2-4 weave W
 H2-3 weave W
 H1-4 weave G

Section V
 lift H1-3 weave G
 H2-4 weave G
 H2-3 weave G
 H1-4 weave G

Section VI
 lift H1-3 weave W
 H2-4 weave W
 H2-3 weave G
 H1-4 weave W

Section VII
 lift H1-3 weave G
 H2-4 weave W
 H2-3 weave G
 H1-4 weave W

Section VIII
 lift H1-3 weave G
 H2-4 weave W
 H2-3 weave G
 H1-4 weave W
 H1-3 weave G
 H2-4 weave G
 H2-3 weave G
 H1-4 weave G

Section IX
 lift H1-3 weave G
 H2-4 weave G
 H2-3 weave W
 H1-4 weave G
 H1-3 weave G
 H2-4 weave W
 H2-3 weave W
 H1-4 weave W

To finish the rugs, the Damascus edge is used as weft protector (see *The Weaver's Journal* Vol. II, No. 2 p. 19). The fringe of rug I is made by twisting and plying pairs of warp ends (see Fig. 4) and finishing with an overhand knot.

The fringe of rug II is made by dipping 4 warp ends into water, rolling them together in the opposite direction of the twist of the yarn as if to make a 4 ply yarn. Finish with overhand knot.



overtwist the already tightly spun wool



ply in the opposite direction of the twist

Fig. 4

NOTICE ALL GUILDS: A free Get-acquainted examination copy of "*The Weaver's Journal*" will be mailed to your president upon request.

Free one-year subscription or renewal to your guild in exchange for nine subscription years from your members (new or renewal) mailed in one envelope, accompanied by full payment.

The Weaver's Journal

1900 55th Street
 Boulder, Colorado USA 80301
 (303) 449-1170

Available back issues:
 Vol. I, No.1, 2, 3; Vol. II,
 No. 2, 3 @ \$2 each. Vol. II,
 No. 4 @ \$2.50 each plus 25¢
 postage per copy. (CO resi-
 dents add 3½% sales tax).
 Allow 6 weeks delivery.

Navajo Double-Faced Rugs

Typically, these rugs are woven by the Navajos on a frame loom using three heddle bars and a shedstick. However, the same patterns can be woven on Summer and Winter threadings. Most Navajo rugs combine stripes and tapestry.

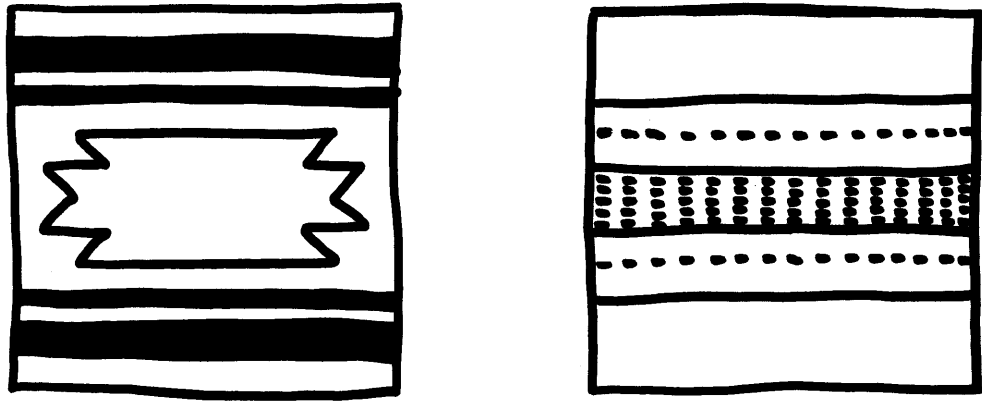

Front

Back

Fig. 5

Fig. 5 illustrates both sides of a typical double-faced Navajo pattern. Only 3 harnesses are required to weave this design on a floor loom. The draft is given in Fig. 6.

Treadles 1 and 3 are used for the front side of the rug, treadles 2 and 4 for the backside. Any two harness weft-face pattern such as weftway stripes, pick and pick, and bands can be woven on either surface, independently of the other. The tapestry designs are woven in the upper face of the rug. They are laid in sheds 1 and 3 while sheds 2 and 4 continue to be used to weave the back face.

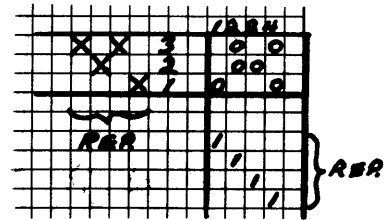

Fig. 6

Some Navajo double-faced rugs combine 2-block designs and tapestry. Plate 4 shows the two sides of such a pattern. Four harnesses are required to weave such designs on a floor loom. The threading draft of Fig. 1 may be used.

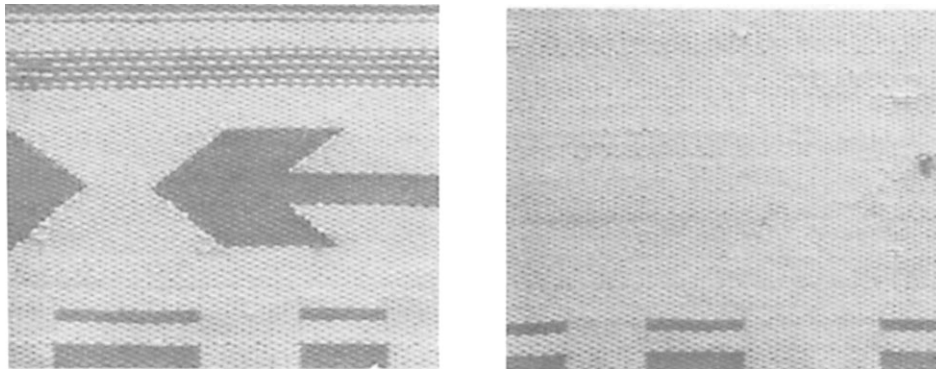

Plate 4
The two faces of the same piece of rug

Fig. 7 shows the complete tie-up and Fig. 8 shows the skeleton tie-up which requires the weaver to select combinations of two treadles to open the sheds.

The blocks are woven by alternating color A and color B.

Stuffer Warp Rug

From experience or from the study of drafts of Summer and Winter rugs, one soon discovers that the warp ends on harnesses 3 and 4 (pattern harnesses) do not interlace with the weft but lay unwoven between the two faces of the rug. Because rugs are seldom more than a few yards long these warp ends do not cause tension problems when the warp is cut and retied after each rug is woven. These warp ends are well protected from wear and do not have to have the strength of usual rug warp. In fact, inexpensive heavy yarn may be used for these warp ends; they will lend extra thickness to the rug without compromising on its durability. This is called the stuffer warp. To insure that there will be no tension problems the stuffer warp should be beamed on a separate warp beam.

Double Faced Coptic Textiles

Plate 5 shows a 4-harness, 2-block Summer and Winter rug which is so colorful and has such a variety of patterns that is more appropriate to call it a decorative wallhanging. Many of the patterns can be isolated and reworked into rug designs. The threading should have many blocks which are only 1 unit wide. In all Summer and Winter rugs the weft floats over 3 warp ends except at the junction between two blocks where the skip is over two warp ends. In the Coptic double faced textiles the typical Summer and Winter threading is modified by adding a warp end on harness 1 at the end of each block. This causes the weft to float over 3 ends at the junction of two blocks. Fig. 9 shows the profile draft, threading, tie-up and treadling for the hanging illustrated.

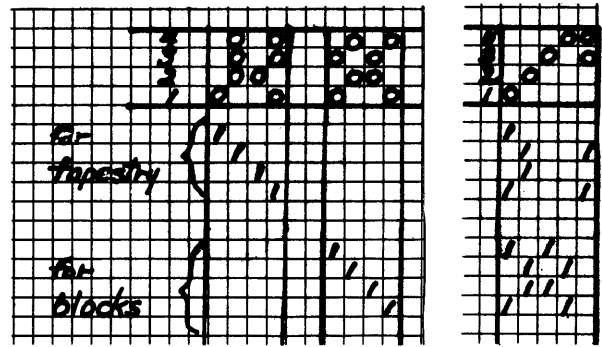

Fig. 7

Fig. 8

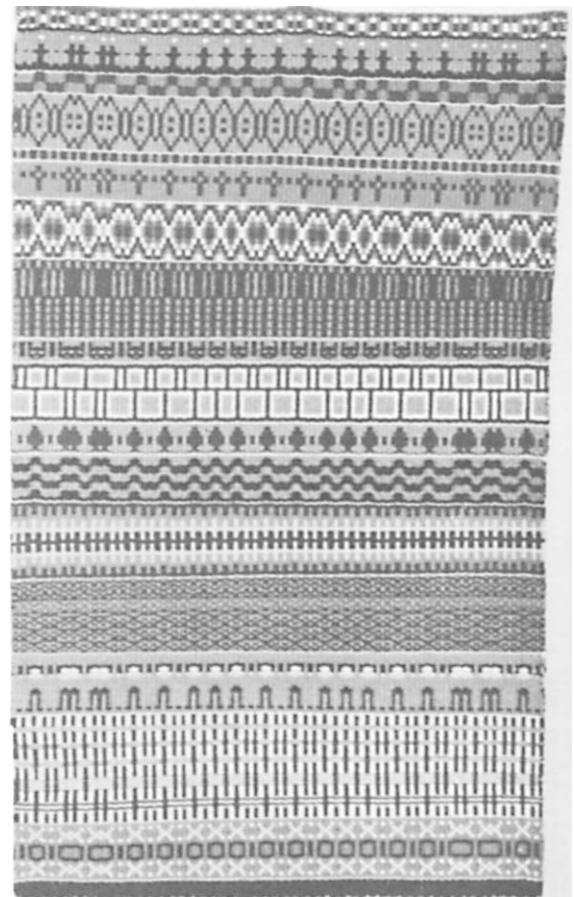
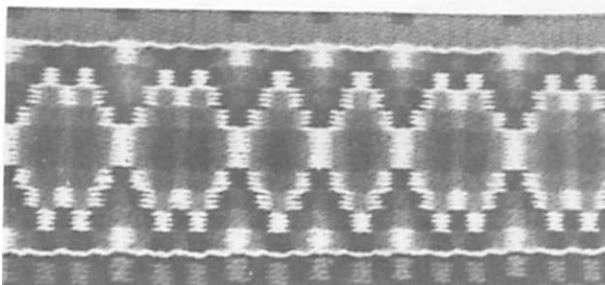

Plate 5

Wallhanging designed and woven
by Ellen Champion



Detail

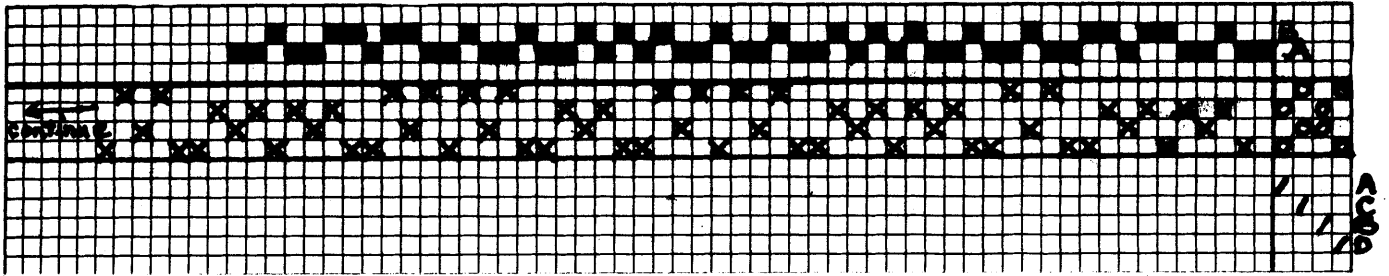

Fig. 9

WARP: tussah silk.
 WIDTH IN THE REED: 31.5" (80 cm).
 SETT: 8 e.p.i. (30/10 cm). Use floating selvedge.
 WEFT: tapestry worsted, Hyslop Bathgate.
 PATTERNS: we selected Egyptian-type patterns which are often done in cardweaving techniques. See "Byways in Handweaving" by Mary Meigs Atwater, p. 5.

Example - Fig. 10

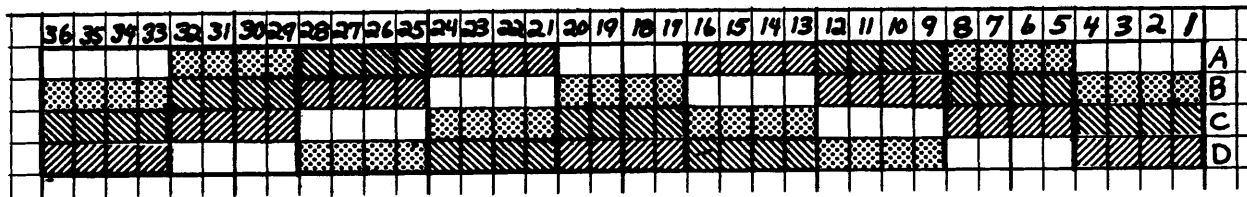

Fig. 10

The treadling of Fig. 9 shows that the sequence of four picks is repeated over and over. Each sequence corresponds to a number indicated above the pattern (see Fig. 10). Within a sequence, shed 1 is woven with the color indicated on row A, shed 2 with color shown on row C, shed 3 with color shown on row B, shed 4 with color shown on row D. Our example is woven with 4 colors

Additional patterns may be designed in the same way as cardwoven patterns. Plate 5 is a sampler using many patterns published for cardweaving and many patterns created as the weaving proceeded.

Multiple Harness Summer and Winter Rugs

The principles of designing multiple harness Summer and Winter block patterns are applicable to rugs. The rugs can be woven "on opposites" with two weft colors A and B or "polychrome" with three weft colors A, B and C.

Plate 6 illustrates an 8-harness, 6-block Summer and Winter rug woven on opposites. The motif for the design is shown in Fig. 11. The profile draft shows that it is a 6-block design.

WARP: 8/3 linen
 WEFT: G - grey }
 F - fawn } 3 ply rug wool from Henry's Attic
 W - white }
 WIDTH IN THE REED: 39½" (100 cm)
 LENGTH OF THE WARP: 3½ yards (3.2 m)
 SETT: 5 e.p.i. (20/10 cm)

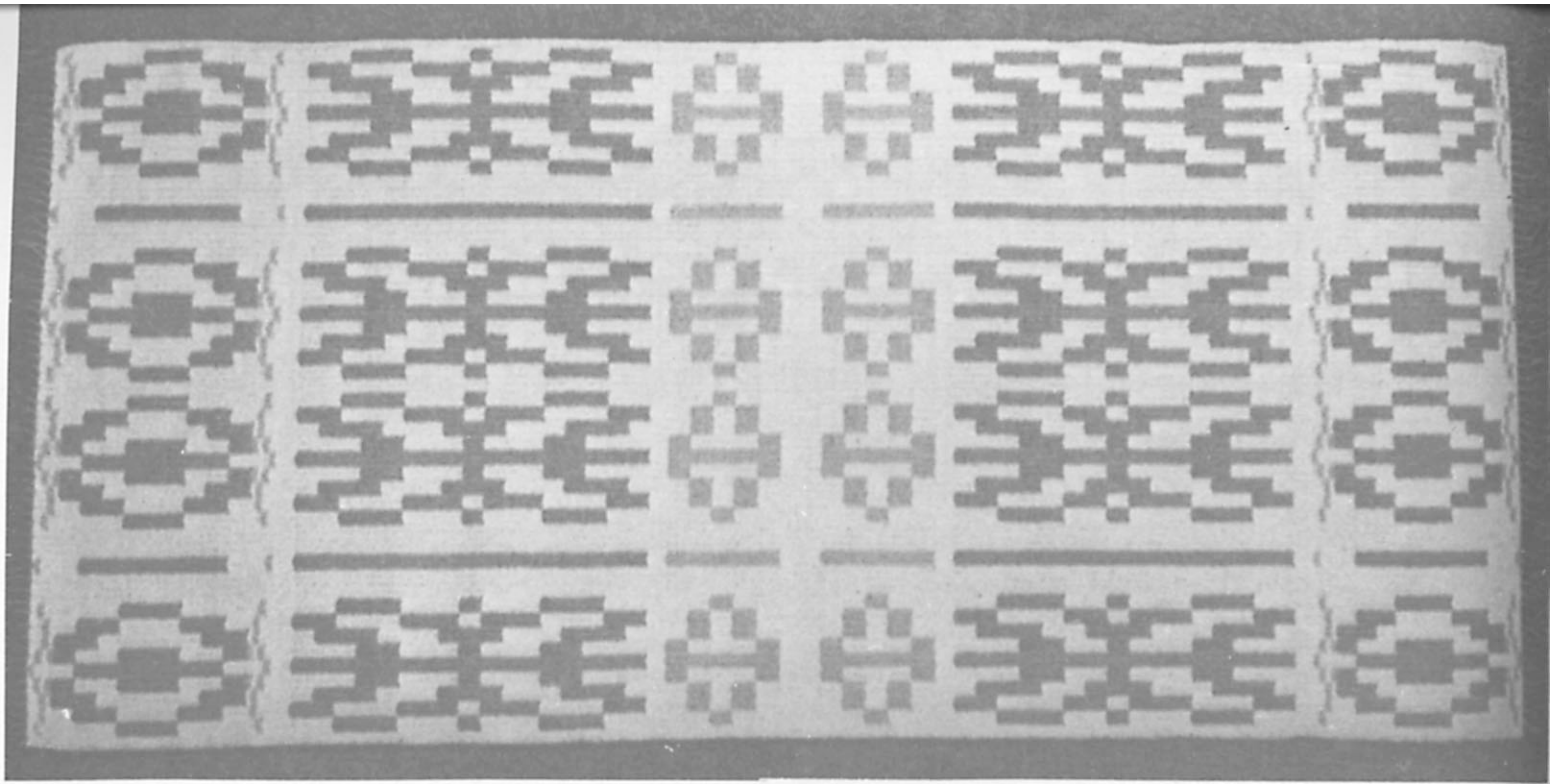

Plate 6

Rug designed and woven by Maxine Wendler

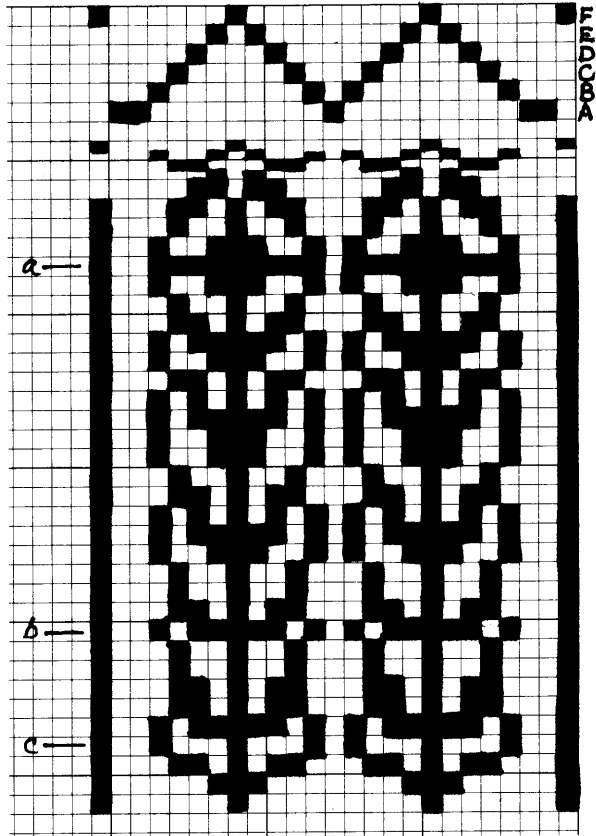

Fig. 11

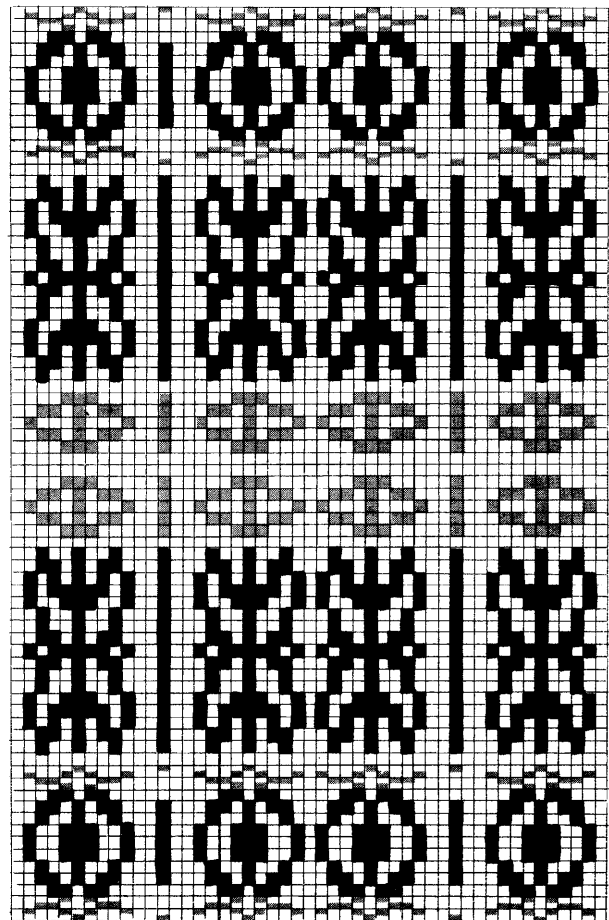
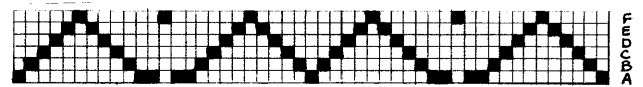

Fig. 12

SLEYING AND SELVEDGES: outer warps, twofold through heddle and reed. Twofold floating selvedge on each side.

TOTAL NUMBER OF WORKING ENDS: 196

TOTAL NUMBER OF ENDS: 202

As each Summer and Winter unit requires 4 warp ends, the rug had to be designed on 49 units or squares of the graph paper. Fig. 12 shows the design and the profile draft of the entire rug. (Helpful hints for designing with blocks are given in *The Weaver's Journal* Vol. II No. 3 pp 6-9). First rearrange the profile of Fig. 11 so that it is spaced out on 49 units. The design in Fig. 12 is derived from Fig. 11 by placing a mirror on lines a, b, c and thus using parts of the original motif plus their mirror images. These new motifs are arranged under the complete profile draft of Fig. 12 and proportioned so that the on-scale drawing forms a pleasing design.

To weave:

Lift H1 plus pattern harnesses of the blocks where color A *does not show* on the surface - weave with weft A.

Lift opposite harnesses - weave with weft B.

Lift H2 plus pattern harnesses of the block where color A *does not show* on the surface - weave with weft A.

Lift opposite harnesses - weave with weft B.

As the weaving requires a large number of different tie-ups, one might find it practical to use both feet for the treadling and press down combinations of treadles rather than single ones.

The rug was finished with a Damascus edge and overhand knots. The finished size off the loom is 36" x 77" (91 x 196 cm) plus fringe.

Polychrome Summer and Winter rugs are woven according to the method II of Polychrome Summer and Winter weaving described in Part I of this article. The differences lie in the weight and quality of the yarns used, and in the sett. The tie-down warp should be thin but strong as it interlaces with the weft to form the surface of the rug. A recommended set is 5 e.p.i. (20/10 cm) and the weft should be rug woollens that pack in well.

The Weaver's Market

SUMMER AND WINTER - TECHNIQUES AND VARIATIONS by Annis W. Jefferson. Booklet of 28 pages giving instructions for four to eight-harness methods. Threadings and treadlings in multi-harness which are not usually found in weaving books. \$3.00 postpaid. Order from Annis W. Jefferson, 3716 Westcliff Road, South, Fort Worth, Texas 76109.

THE INKLE PATH TO WEAVING. Another book by Teresa Folts, who wrote "Warping the Loom Alone": 130 illustrations by David Mathieson, 13,000 words of explicit instruction, 88 pages, retail \$9.95, from Serenity Weavers, 111 West Seventh, Eugene, Oregon 97401.

PLAYING WITH BLOCKS: AN EXPLORATION OF MULTIHARNESS OVERSHOT by Erica Voolich. Four threading systems explained and illustrated; numerous tie-ups and drawdowns; and a step by step method for figuring out tie-ups. Order from Erica Voolich, 244 Summer, Somerville, Mass. 02143. \$3.95 (Mass. residents add .20 tax).

Six harness Summer and Winter rugs with overshoot patterns

Traditional patterns of Colonial overshoot are woven in dark and light. They are characterized by a 4-block 3-tone weave. See Fig. 13.

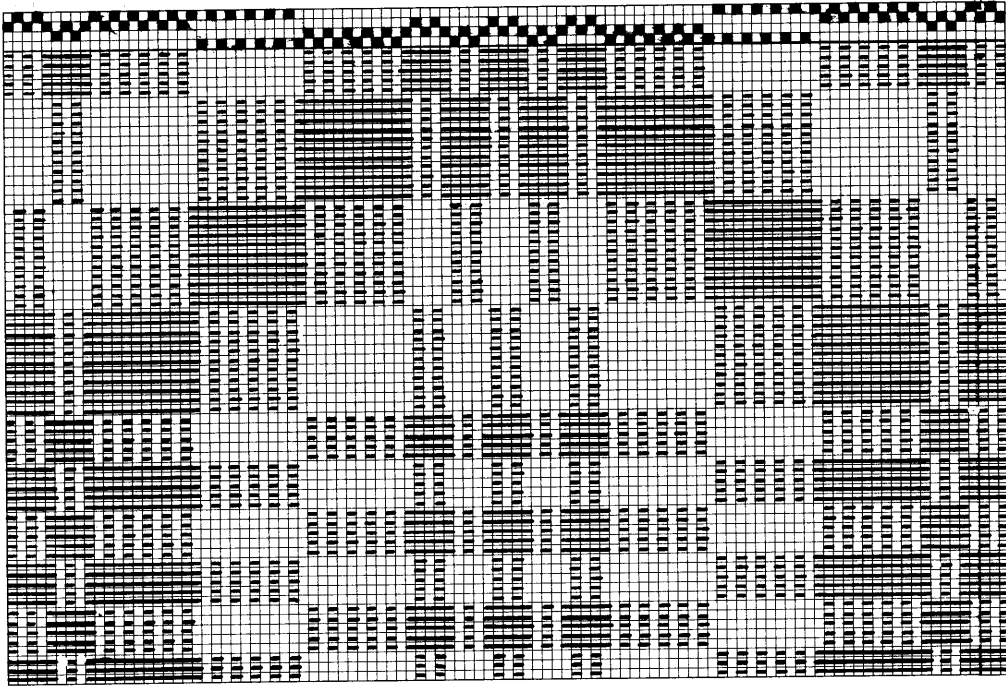

Fig. 13

Many bound weave rugs are based on overshoot threading; see *The Weaver's Journal*, Vol. I No. 4, pp. 3-10, Vol. II No. 1 pp. 20-22. However they do not have the 3-tone appearance of the classical overshoot and care must be taken to reduce the blocks in size to avoid long weft floats.

Four-block Summer and Winter requires 6 harnesses. However there are no limitations of block sizes as the weft floats over only 3 ends. The three tones are achieved with two colors A and B. They are solid A, solid B, and warpway stripes generated by the pick and pick technique of alternating A and B.

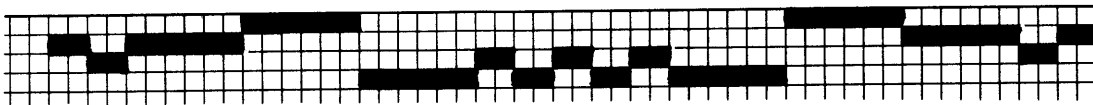
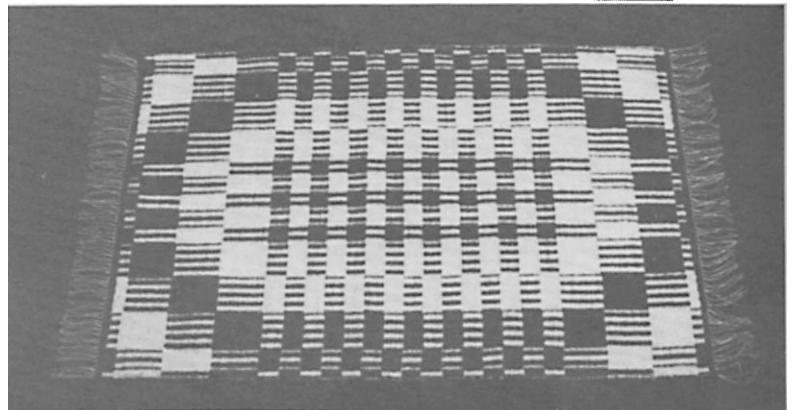

Fig. 14

Plate 7 shows a rug woven on Summer and Winter patterned after the design of Fig. 13.

Fig. 14 shows the profile development of the overshoot shown in Fig. 13.

Plate 7
Rug woven by Ellen Champion



WARP: 6 cord linen.
 WEFT: 3 ply rug wool, white, Henry's Attic.
 3 ply rug wool, brown, Raye's Eclectic.
 SETT: 5 e.p.i. (20/10 cm).
 SLEY AND SELVEDGES: double the two outer warp ends in the heddle and the reed.
 Use a floating selvedge.
 WIDTH IN THE REED: 32" (80 cm).
 TOTAL NUMBER OF WORKING ENDS: 160.
 The profile draft design has to be based on Fig. 14 but using only 40 units
 (each sequence = 4 ends).

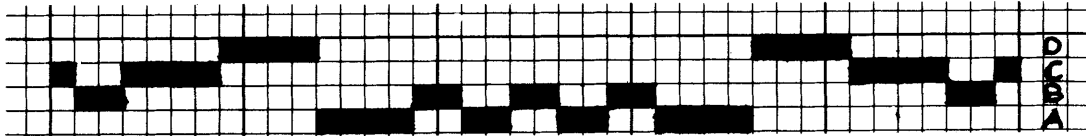

Fig. 15

Fig. 15 shows the final profile draft.

TO WEAVE: dark in A (white in C and pick and pick in B and D)

step on treadles 1 and 5 dark
 step on treadles 2 and 3 white
 step on treadles 2 and 5 dark
 step on treadles 1 and 3 white

TIE-UP:

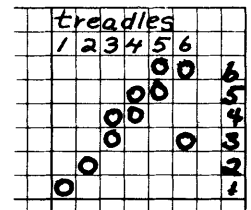

TO WEAVE: dark in B (white in D and pick and pick in A and C).

step on treadles 1 and 6 dark
 step on treadles 2 and 4 white
 step on treadles 2 and 6 dark
 step on treadles 1 and 4 white

TO WEAVE: dark in C (white in A and pick and pick in B and D).

step on treadles 1 and 3 dark
 step on treadles 2 and 5 white
 step on treadles 2 and 3 dark
 step on treadles 1 and 5 white

TO WEAVE: dark in D (white in B and pick and pick in A and C).

step on treadles 1 and 4 dark
 step on treadles 2 and 6 white
 step on treadles 2 and 4 dark
 step on treadles 1 and 6 white

Any overshoot may be woven in the same manner. The Coptic technique described previously, which adds a warp end on harness 1 after each block, may be used for these rugs.

A future article will discuss rugs woven on other two tie-down weaves, especially double Summer and Winter.



Furniture in Coiled Basketry Technique

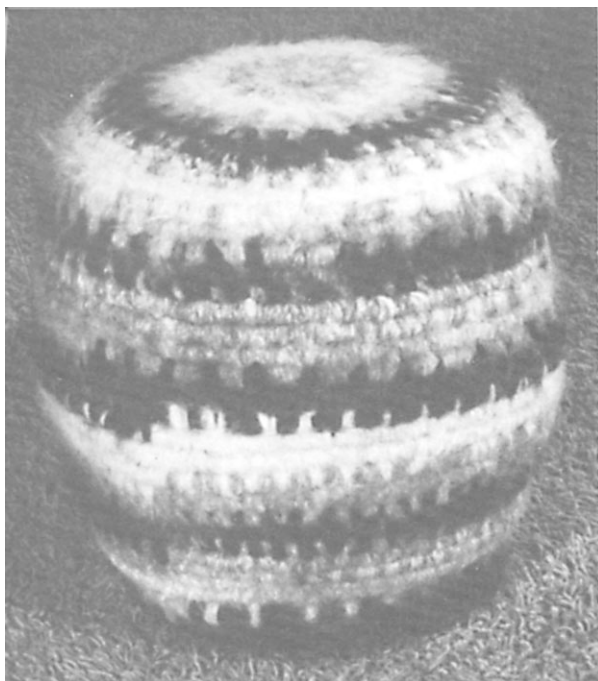

Plate 1
Coiled Hassock by Clotilde Barrett

Basketry techniques lend themselves well to making easy semi-soft furniture. The coiling method is described in many textbooks. The illustrations of Fig. 1 will serve as a guide for the stitch used in our furniture.

The hassock illustrated in Plate 1 is made in two parts. The bottom is a flat coiled disk (Fig. 2). The top part is an upside down basket shown in Fig. 3. The core for both parts is made of several strands of heavy jute and is about 3/4" (19 mm) in diameter. The wrapping yarn for the bottom is jute. The wrapping yarn for the top is handspun and plyed dog hair: white from Samoyeds and tan from collies. The coils are wrapped for about 3/4" (19 mm) and then secured to the previous coil with two figure-8 stitches. The top part is stuffed with cotton batting and sewn onto the bottom disk.

In order to make the seam invisible the core A B is wrapped with doghair for 3/8" (9.5 mm), then sewn to the last coil of the top part with two figure-8 stitches. The core is then wrapped for another 3/8" (9.5 mm) and sewn to the previous coil of the bottom part with two figure-8 stitches, etc.

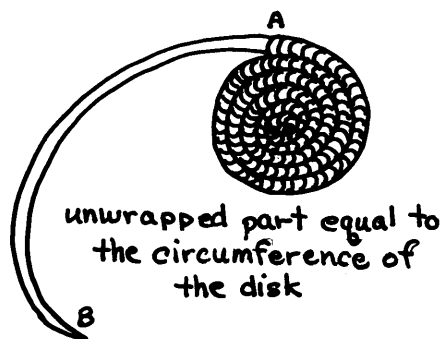
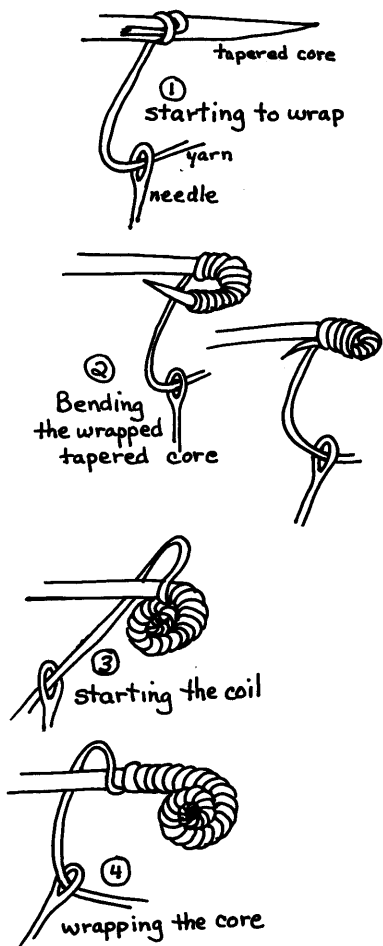

Fig. 2

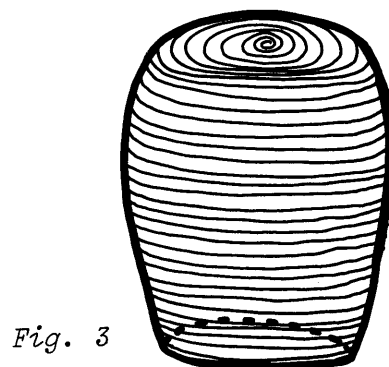

Fig. 3

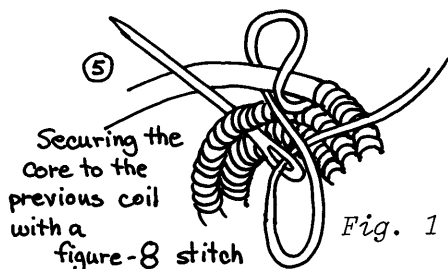
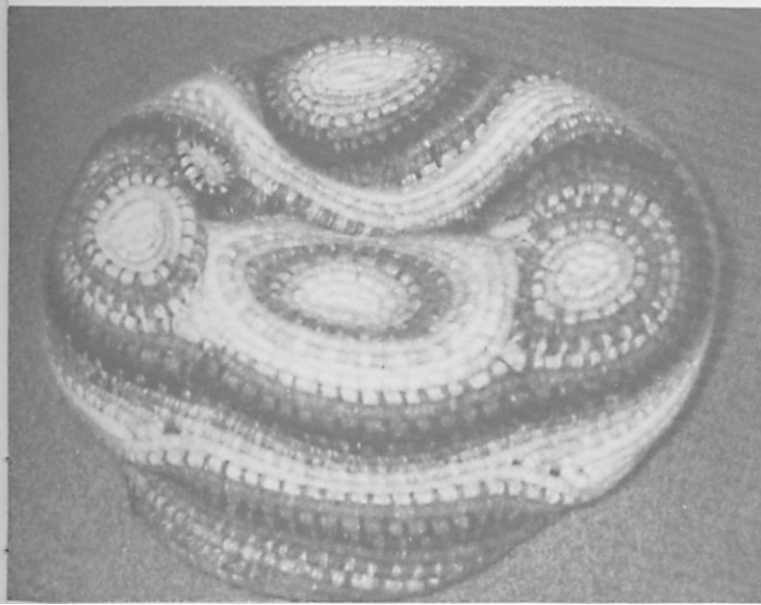

Fig. 1

SUPPORT OUR ADVERTISERS!



The seat illustrated in Plate 2 is made from several coiled sections sewn together in the same way as the parts of the hassock. The core is sisal, 3/4" (19 mm) in diameter. The core must always be tapered for starting, splicing or ending. The wrapping yarn is handspun and plied karakul sheep in white, grey and black. The coiling technique is the same as for the hassock and cotton batting was also used to stuff the seat. In some sections a black lining had to be secured between the coils and the stuffing as the white stuffing tended to show through.

Plate 2
Coiled Seat by Clotilde Barrett



A Reversible Jacket in Double Weave by Jane Evans

Few garments suggested for handweavers encourage them to cut and shape their handwoven fabric, usually to the detriment of both the weaving and the human form. The pattern described herein, which is based on a Welsh fisherman style jacket, is a compromise between minimal cutting (for fit) and large areas of fabric (for show). The size is in a medium range. To check fit, it is suggested a sample jacket be made of sheeting. This sample can then be used as the pattern when cutting your handwoven cloth. Pattern pieces are described on the layout, Fig. 1.

SPECIFICATIONS

WARP: 6 meters long, 76 cm wide in reed (6½ yards by 30 inches).

a) 20/2 wool, copper red and two shades of moss green used two fold; each color was doubled in warp and treated as a single thread (2 strands).

b) wool boucle, pale copper, used single strand.

WARPING ORDER: see threading draft, Fig. 2.

WEFT: same as warp, on 3 shuttles.

SETT: 80/10 cm (20 working e.p.i.) - sleyed 2 double ends, or 1 double end plus 1 boucle end, per dent in a 10 dent/inch reed.

AMOUNTS FOR PROJECT: about 1 lb. 3 oz. (540 g) each, copper and combined greens, 20/2 wool; 17 oz. (485 g) wool boucle.

THREADING AND TREADLING: The jacket was woven from the draft given in Fig. 2. Treadling number I was used. This gives a stitched double weave, plaid on one side, dotted on the other. Beat lightly to keep the plaid squared. The fabric measured 70 cm x 525 cm (27½" x 207") off-loom. After being washed in warm water and soap, and tread for one-half hour, it was dried and steam pressed. Size after pressing was 63.5 cm x 505 cm (25" x 199").

CONSTRUCTION: To allow for a reversible garment, all seams are flat-felled. In the double-woven fabric, this calls for careful cutting and folding to avoid stiff bulk. Fig. 3 describes the steps.

Material 180" long, 25" wide

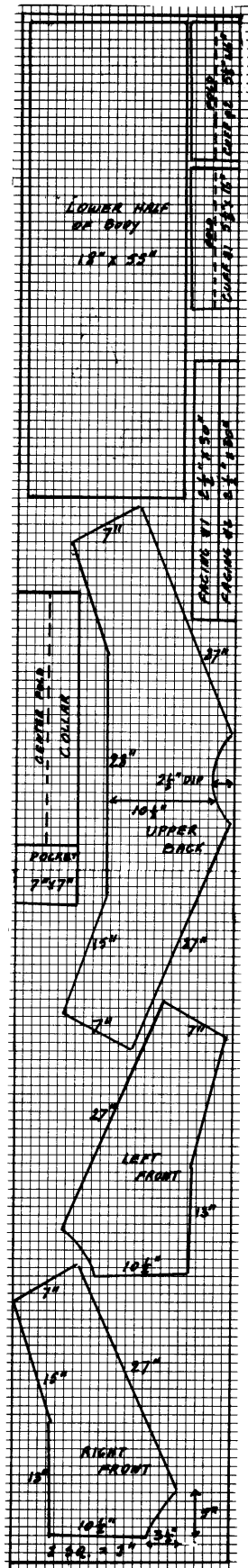

Fig. 1

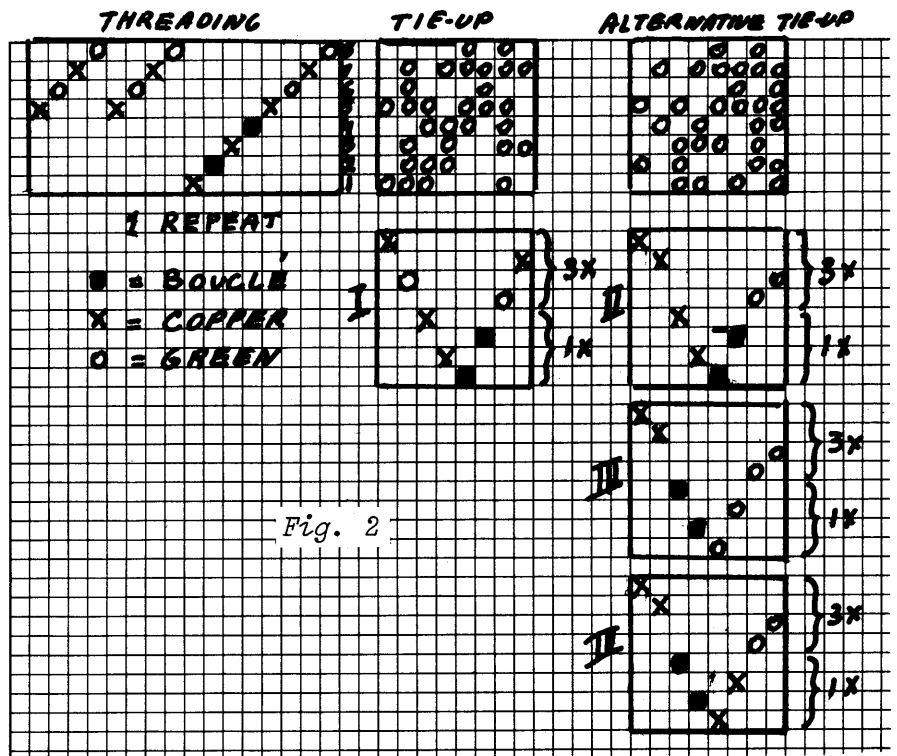

Fig. 2

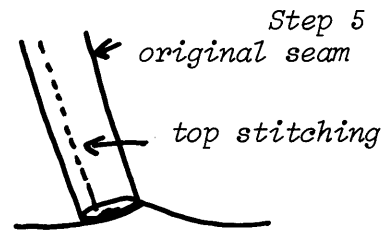
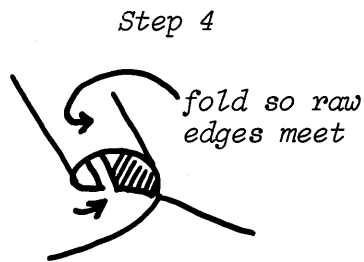
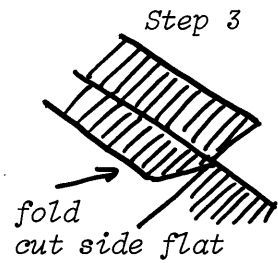
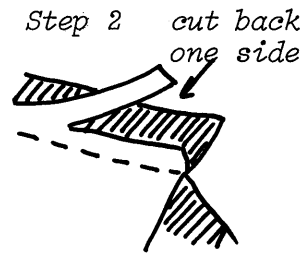
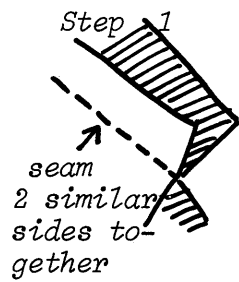
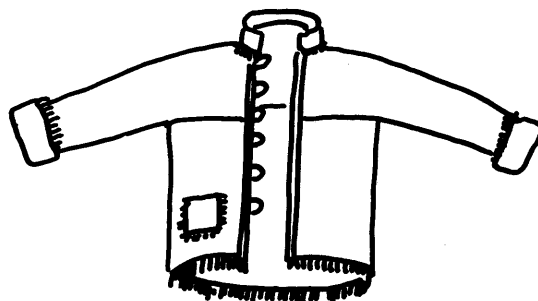
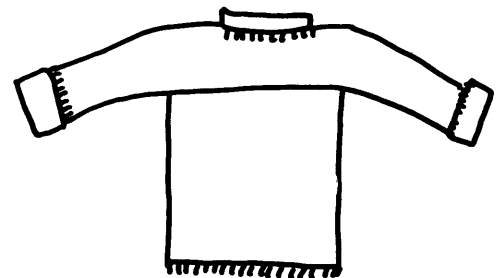

Fig. 3



Front View



Back View

Fig. 4



*Double Weave Jacket woven and modeled by Jane Evans
Front view, showing contrasting surface patterns between
collar (dot) and body (plaid)
Photo by Susan Close*

Be sure to iron and baste, with thread, not just pins. Steps 3 and 4 are crucial to a neat and straight finished seam. Step 5 is to top-stitch through all layers, again being careful to maintain straight lines. Because of the regular repeat of the pattern, any deviation from a straight line is noticeable.

The collar, cuffs, pocket, and lower edge of the garment are left with $1\frac{1}{4}$ cm (one-half inch) fringe. There is a row of stitching to keep this from fraying back.

A facing is applied to both sides of the front opening. This avoids the opposite side's color forming a stripe, as it would if simply turned back. Inserted between and emerging from the facing and front are braided loops for buttons. On the opposite front side, buttons are

sewn on both faces of the fabric to accommodate reversing the jacket; i.e., twelve buttons, six on each face, are used.

VARIATIONS: A hood would be possible, instead of the cowl collar. There is some fabric left over from a six-meter warp for such a purpose. More pockets may be cut out, also.

If the garment is not used as a reversible jacket, a zippered front is an alternative. The facings could be omitted for less stiffness, although it would give a better look to the edge to use them.

The treadling variations in Fig. 2 give striped and other patterned fabrics. All of them preserve the insulating warmth of a double weave.

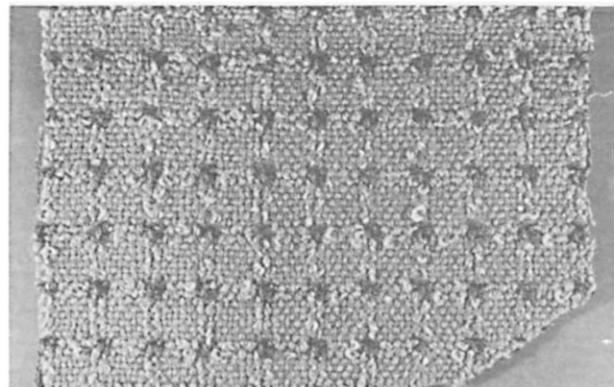
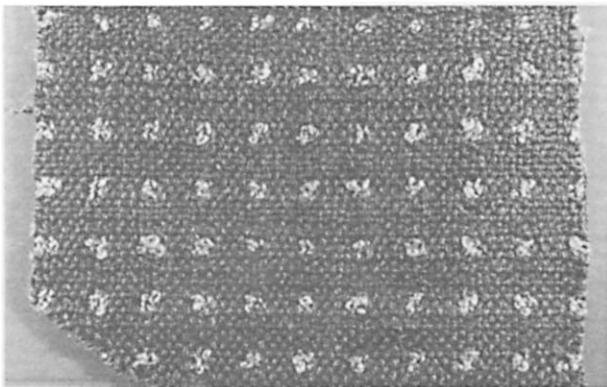

Two sides of the stitched double woven fabric used for the jacket





Instructions for Weaving a Bog Shirt

by Barbara Kinahan

A Bog Shirt is a loose-fitting pullover garment with 3/4 length sleeves. When I bought my shirt in California, I was told that the reason for the name "Bog Shirt" is that the remnants of a similarly styled garment from ancient times had been unearthed from a Scandinavian bog. The shirt I bought was woven entirely of cotton---the warp was Lily's Bouclé and the weft, "Butcher string". I find it very comfortable to wear over a turtleneck and pants. See Fig. 1.

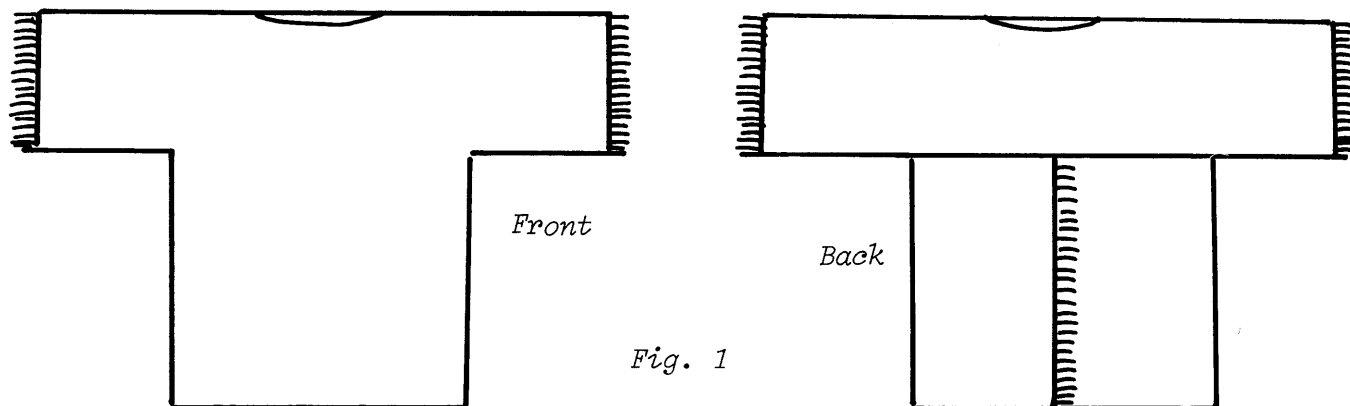

Last Fall, Cory Grill and I decided to weave 3 of these shirts on her loom as we needed a full 40" (102 cm) on the loom. For our warp we used a cotton and rayon slub. After some experimentation on our small loom we decided on a sett of 12 e.p.i. (50/10 cm). The threading, tie-up and treading was for plain weave. For weft I used a soft 2-ply cotton - almost oatmeal in color.

Cory wove her shirt with 2-ply medium wool alternating with a single of white wool. The 11" of the neckline area were done with medium weight handspun and the other 2 wefts.

For 3 shirts - WARP LENGTH: 58" (147 cm) x 3 = 174" (4.42 m)
 + $\frac{36"}{210"}$ (91 cm) loom waste
 or 7 yards (5.33 m)

SETT: 12 e.p.i. (50/10 cm)

To Weave

Weave the garment flat for 20½" (52 cm), then using 2 shuttles make a neckline slit 11" (28 cm) long, then weave another 20½" (52 cm). See Fig. 2.

Editor's note: For an interesting variation one could weave the slits A - B shown in Fig. 3 rather than cutting them.

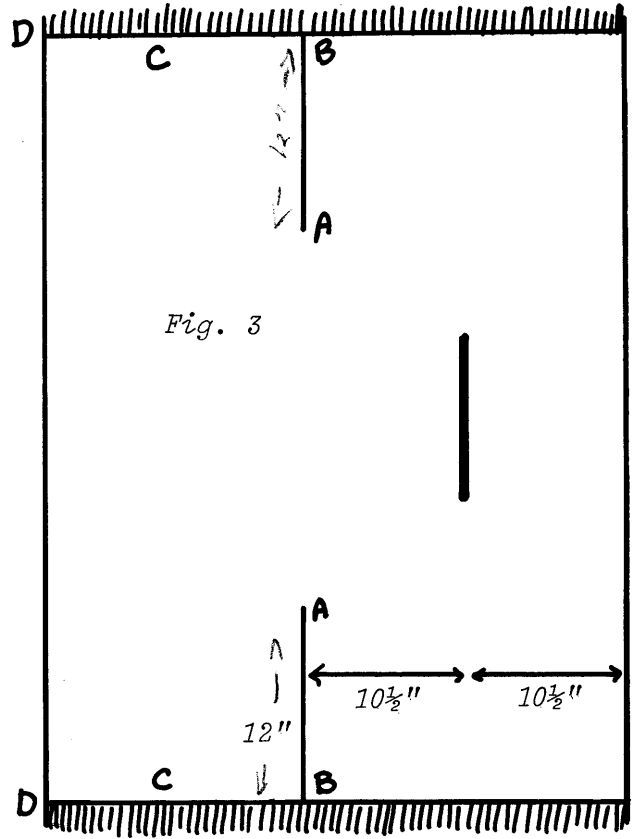
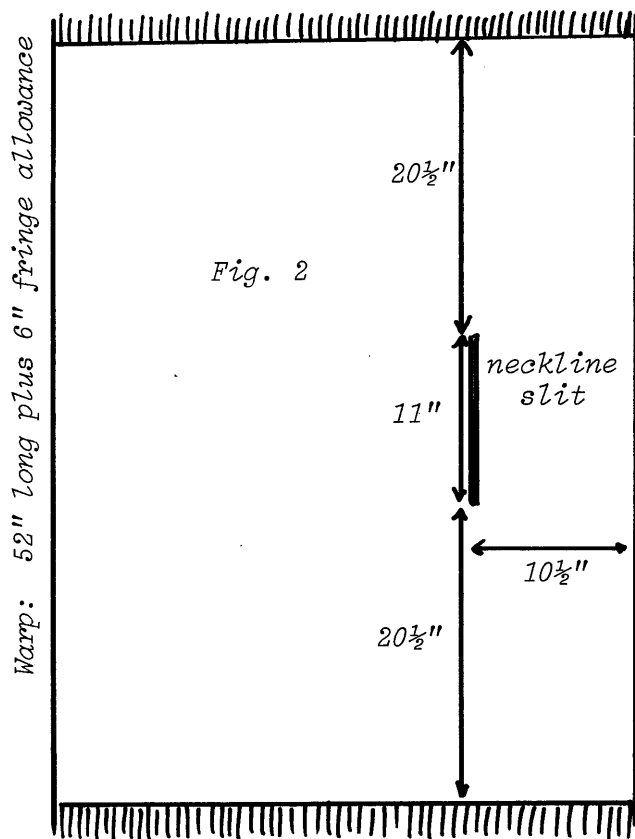

To Make Up

Have fabric well pressed by the dry cleaner - I found no shrinkage in the length but while the warp was on the loom at 40" (102 cm), it wove at 39" (99 cm) and after pressing the width was 36" (91.5 cm):

Lay fabric out flat - in the manner it was woven. After measuring from the right selvedge to neckline slit, measure the same distance to the left of the slit - this will ensure that the sleeve lies true. Then measure from points A to points B on edges and mark this seam a distance of 12" (30 cm). When that is done, machine-stitch 2 close lines from B to A and cut between stitching. Next bring fabric areas marked C together and sew the seam marked B to D - leaving fringe on the outside - this is your center back seam. Now turn the garment inside out; a simple long seam from the bottom of one sleeve across the shoulder blades and down the other sleeve is easily sewn together.

Photos by Barbara Kinahan, Bog Shirt modeled by daughter, Theresa



Corded Weaves: Four Harness Cords for Upholstery Fabric, Drapery Material and Wallhangings

Exploring corded weaves is an interesting but almost endless pursuit. The structure of these weaves produces a characteristic corrugated effect. The cords (or ribs) may run lengthwise (in the direction of the warp) or crosswise (in the direction of the weft). Patterns can be designed combining lengthwise and crosswise cords.

This introductory article will deal only with the lengthwise cords that can be woven on a four harness loom. The samples of the first three cords described are woven as follows:

WARP: 2 ply Maypole Willamette.
WEFT: same as warp but in a darker tone.
SETT: 36 e.p.i. (140/10 cm).

The sett for cords should be closer than for balanced plain weave. The corrugated effect shows up better after the fabric has been full'd (or washed).

Corded Weave #1. (Plate 1)

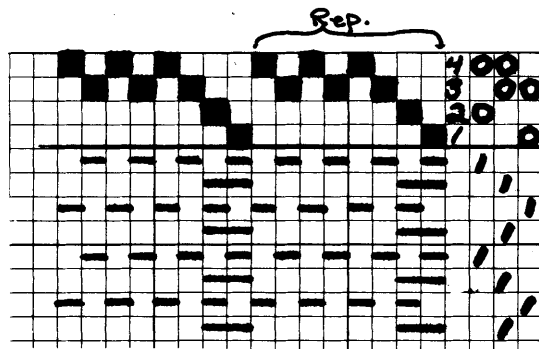

Fig. 1

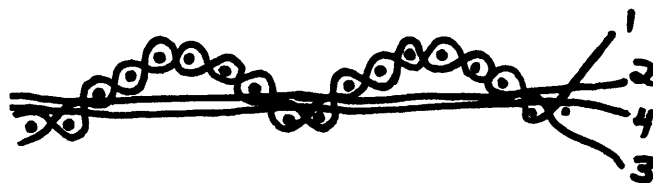

Fig. 2

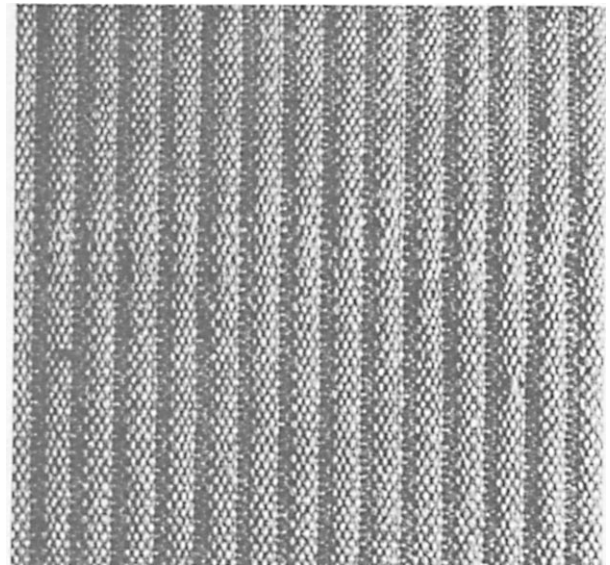
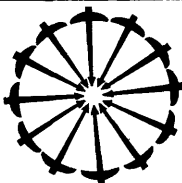

Plate 1

Fig. 1 shows the draft and Fig. 2 shows the interlacement of this corded weave. Note that pick 2 and 4 float on the back under 6 (or more) ends and float over two ends. These are called the floating picks. Pick 1 and 3 interlace with the warp in a plain weave. They are the binding picks.



COLORADO FIBER CENTER, INC

Studio of *The Weaver's Journal*
for 1978 - 1979 schedule write to:
1900 55th Street, Boulder, CO 80301

- classes
- workshops
- supplies

Corded Weave #2. (Plate 2)

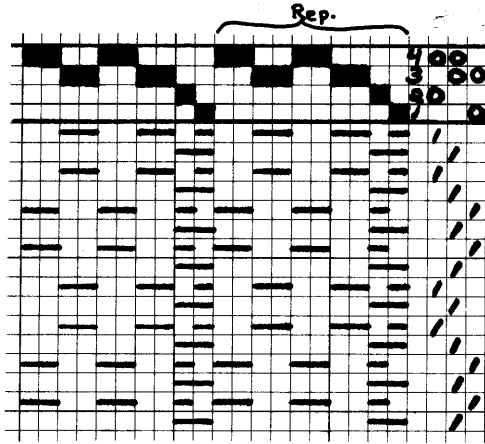

Fig. 3

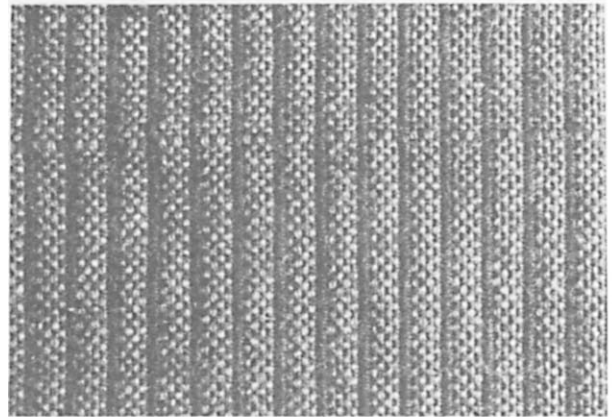

Plate 2

Fig. 3 shows the draft. This corded weave is similar to #1 in structure and appearance. However, here the binding picks weave a basket weave instead of a tabby.

Corded Weave #3. (Plate 3)

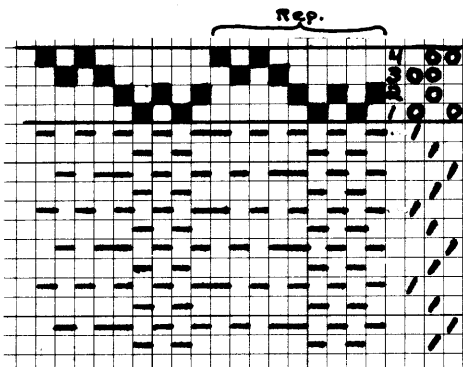

Fig. 4

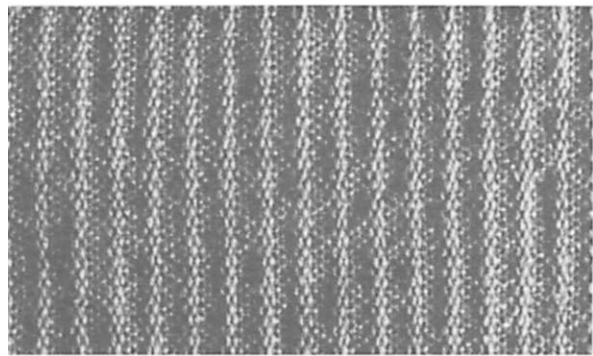

Plate 3

Fig. 4 shows the draft. The cords are farther apart and stand out as strong ridges.

Corded Weave #4. (Plate 4)

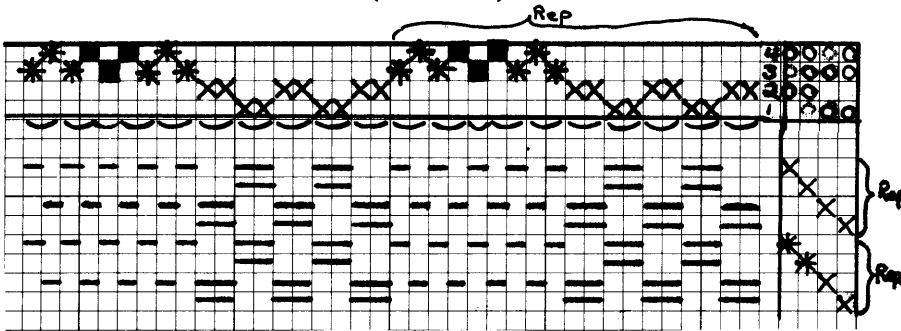

Fig. 5

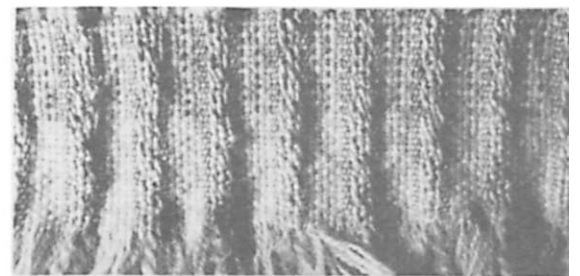

Plate 4

Fig. 5 shows the draft.

- X 2/18 brown worsted wool - Clasgens
 - * 2/18 gold worsted wool - Clasgens
 - 2 ply tapestry worsted - grey
- 15 dent reed, sleyed as diagrammed under the threading.

Upholstery fabric based on corded weave #3.

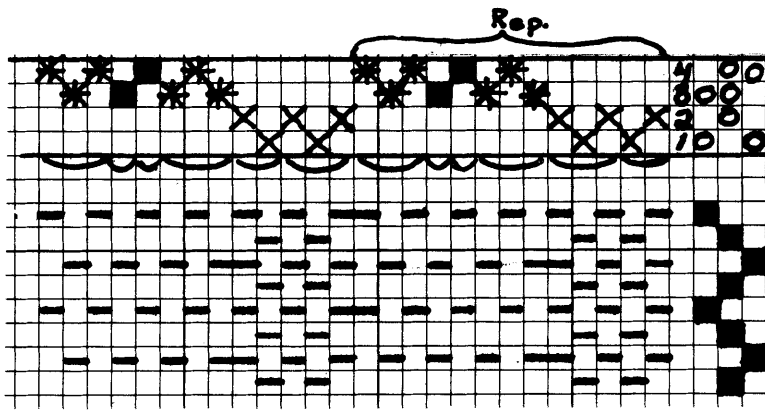

Fig. 6

Fig. 6 shows the draft.

- * 2/18 brown wool worsted Clasgens.
 - X 2/18 orange wool worsted, Clasgens.
 - 1/2½'s brown tapestry worsted, Hyslop Bathgate, Galashiels.
- SETT: 26 e.p.i. (100/10 cm)
 in a 12 dent reed, sleyed as diagrammed under the threading.
 WEFT: 2/2½'s tapestry worsted.

For upholstery fabric these corded weaves should be tightly interlaced on the surface. For draperies the corded effect can be enhanced by alternately crowding the warp and skipping dents. For wallhangings wide cords could be stuffed by hand after the fabric is woven.

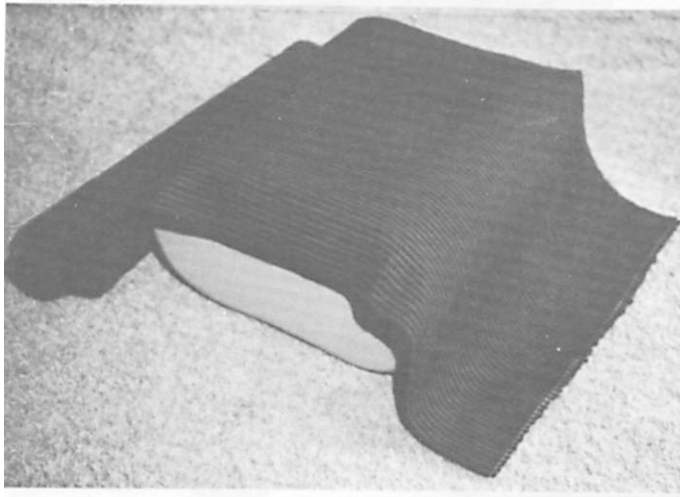
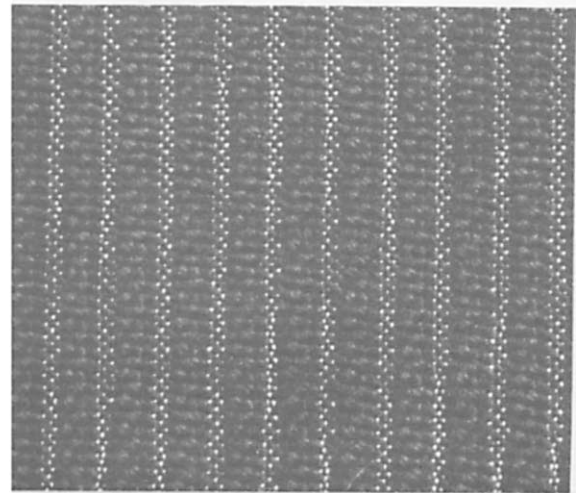



Plate 5

Corded Upholstery Fabric



Detail of Plate 5



by Olive and Harry Linder

An authoritative guide for craftsmen interested in learning the secrets of cotton spinning; tools, preparation of fibre, scouring, mordanting, natural dye recipes, shrinkage formulas, uses of handspun thread, plus directions for building your own Charka wheel. 6 x 9, illustrated, paperbound 50 pp. 6.25 post paid. Dealer inquiries welcome.

To: THE COTTON SQUARES
 1347 E. San Miguel Avenue
 Phoenix, Arizona 85014

Wool Finishing

by Francis Mayer

This is Part III of a series on wool dyeing and finishing for the handweaver.

Once stock or yarn has been dyed and woven (or woven and piece dyed as the case may be), some finishing may be required to relax, or full, and felt the fabric. Relaxing can be accomplished by allowing the fabric to stand for 10-15 minutes in water containing some wetting agent.

The object of milling or fulling is to convert the loose fabric into the denser and more durable cloth. The milling process is based on the property of the wool fiber to felt when wet. This is especially true when warmed in the presence of soap, detergent, alkali or acid, under the influence of pounding or pressure.

Alkaline milling is carried out at a (lukewarm) temperature with as little liquor as possible, for 15-60 minutes or even longer, according to the kind of cloth and the type of machine used. The milling agents are soda ash solution with soap or wetting or scouring agents. Their concentration and the pH of the solution depend on the quality of the wool and the goods. Very dry and very hot milling is to be avoided, and as soon as possible after milling, the goods should be washed gradually in the dolly washer or open width washing machine to remove the alkali inside the wool.

Acid milling is mostly used for felt and hat making. The milling agents are dilute sulphuric, formic or acetic acid. The milling process itself is the same, but in acid conditions the felting sets in more rapidly. After milling, the goods should not lie around too long, as they may dry out in part and thus produce uneven dyeing.

For lightweight dress goods, water milling with 1% detergent may be sufficient.

Lastly, felting can be achieved by wetting out the fabric and running it in an upright washing machine or tumble dryer, followed by a washing off and drying.

Lightweight worsted fabric which has not been shrinkproofed may shrink or felt in dyeing or finishing. To avoid this it is subjected to a crabbing process. The pieces are passed at full width into a container fitted with guide rollers, wound under pressure in boiling water onto a perforated roller and treated for 15-30 minutes. After crabbing, the goods are usually passed in open width, through cold water, or left wound on the roller until cool.

The above operations are called wet finishing. Dry finishing such as napping, pressing and/or steaming also can be used. Napping is done with a stiff brush or abrasive material which catches and distorts the surface fibers to impart a raised surface and a very soft hand. Hot pressing and/or steaming is the last finishing operation which consolidates the cloth and gives the final hand and appearance to the fabric. Steaming gives a dull surface, while heat and pressure produce a shiny lustre.



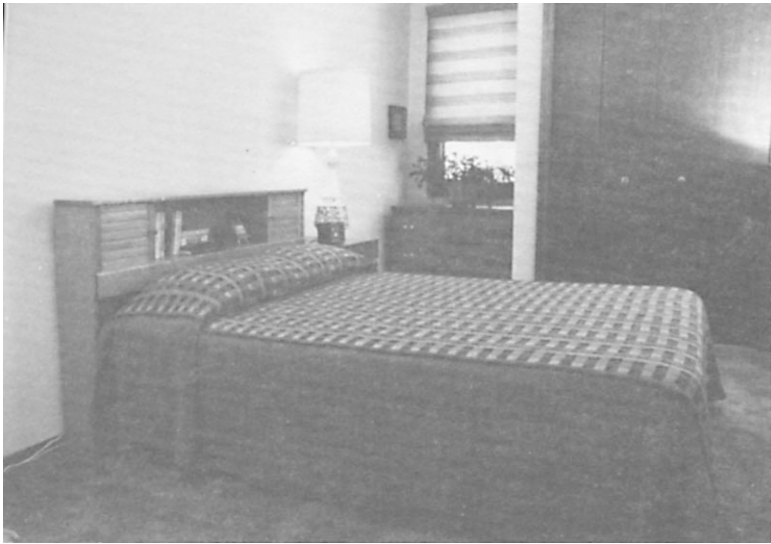

Roman Shades and Bedspread

Moving into a new house can cause many problems for a handweaver who is determined to weave all the textiles for her home environment. Maxine Wendler wove her bedspread in 1974. The pattern is Summer and Winter for which the draft is given in Fig. 1 and Fig. 2.

Plate 1
Bedspread and Roman Shade
by Maxine Wendler

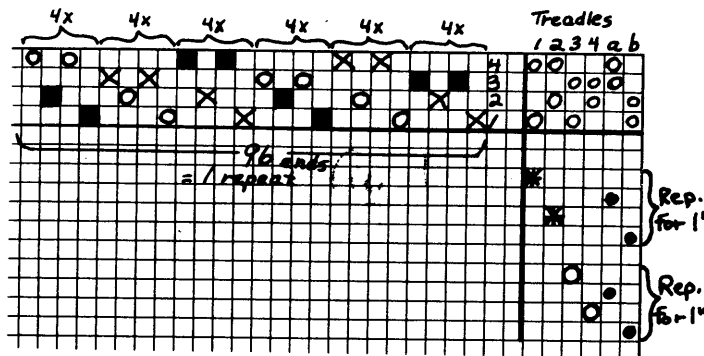

Fig. 1

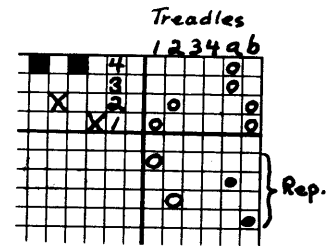

Fig. 2

WARP: 2 ply Maypole Willamette, Oregon Worsted Co.
X - dark brown
■ - gold
O - natural

WIDTH IN THE REED: 38" (96 cm) for the 2 top panels, 27" (69 cm) for the 2 side panels.

SETT: 15 e.p.i. (60/10 cm).

WEFT: pattern - *nubby brown, ●orange-rust tweed all about size 5/1 wool
tabby - o yellow-green

Four years and a new house later, Maxine had to design window covering that harmonized with the bedspread and fitted in the window design of the bedroom. She decided on lined Roman shades. The amount of left-over weft yarns of the bedspread had to be carefully evaluated and used only in crosswise bands. The tabby background was woven with Maypole Willamette. The cloth was woven as follows:

WARP: 2 ply Maypole Willamette, Oregon Worsted Co.
■ - gold
O - natural

THREADING: see Fig. 3

SETT: 15 e.p.i. (60/10 cm)

WIDTH IN THE REED: 36" (90 cm)

WIDTH OFF THE LOOM: after dry cleaning, 32" (81 cm).

WEFT: ■ gold, 2 ply Maypole Willamette
 * nubby brown
 ● orange-rust tweed
 ○ yellow-green

DESIGN OF THE CLOTH: alternate $3 \frac{7}{8}$ " (9.85 cm) tabby and $3 \frac{1}{8}$ " (7.95 cm) of pattern. The treading is shown in Fig. 3.

How to make Roman shades:

For a window 32" W x 54" L (81 x 137 cm) allow 58" (147 cm) long. Cut drapery material $33 \frac{1}{2}$ " (85 cm) wide and 58" (147 cm) long. Cut lining $32 \frac{1}{2}$ " (82.5 cm) wide and 58" (147 cm) long. Sew lining and fabric together on sides and bottom. Turn right side out and press.

Cut $\frac{3}{8}$ " (10mm steel rod 32" (81 cm) long and cover by making a tube of lining fabric. Hand stitch $\frac{1}{2}$ " (12.5 mm) from bottom of drape so that stitches won't show on right side. Insert covered rod into bottom of drapery panel. The rod will actually rest on this stitching and seems to give a better look to bottom of drape. Now lay lined drape right side up on floor or table and pin layers together so it is very straight and even. To mark for placement of rings start at edge and place a pin about $1 \frac{1}{2}$ " (38 mm) in and 6" (15 cm) from bottom and space them 6" (15 cm) to 12" (30 cm) apart in a straight line across fabric. See Fig. 4. Pin through both thicknesses.

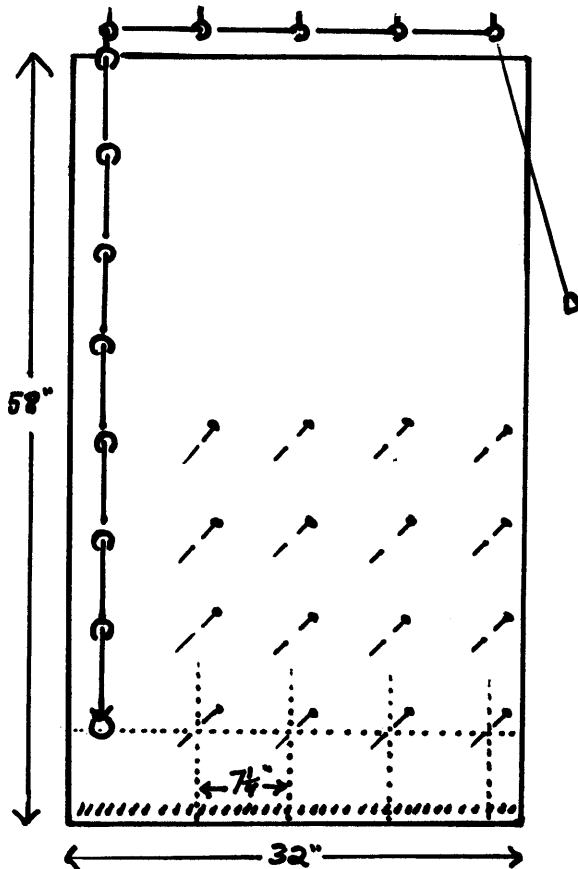

Fig. 4

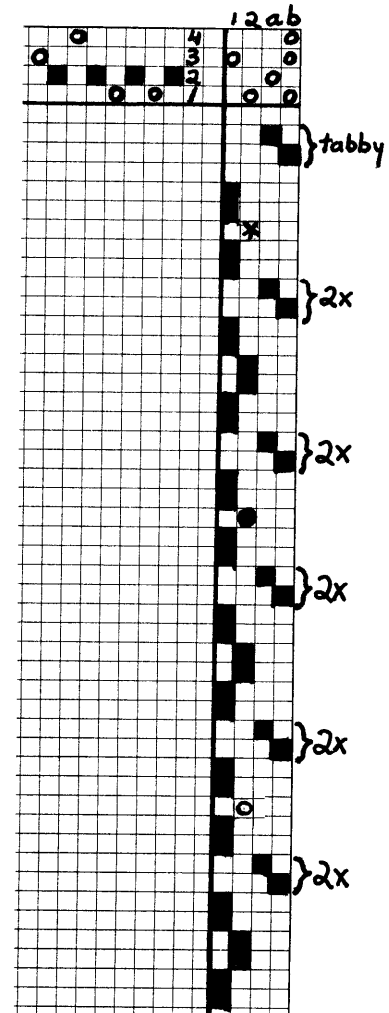

Fig. 3

The spacing of the vertical rows depends on the firmness of the fabric; since the example shown was a fairly loose textured fabric, 5 vertical rows were needed and they were spaced $7 \frac{1}{2}$ " (18.5 cm) apart across row. The horizontal rows were spaced 6" (15 cm) apart (which makes the folds 3" (7.5 cm) wide) and there were 8 folds. The folds could have been wider but the pattern stripe in the woven fabric determined the width of the folds.

Now turn the panel over and sew small rings through both thicknesses. Next take nylon cord and tie to bottom ring and thread up through rings, running cord across top of drape and half way down side. See Fig. 5. Continue this procedure with each vertical row.

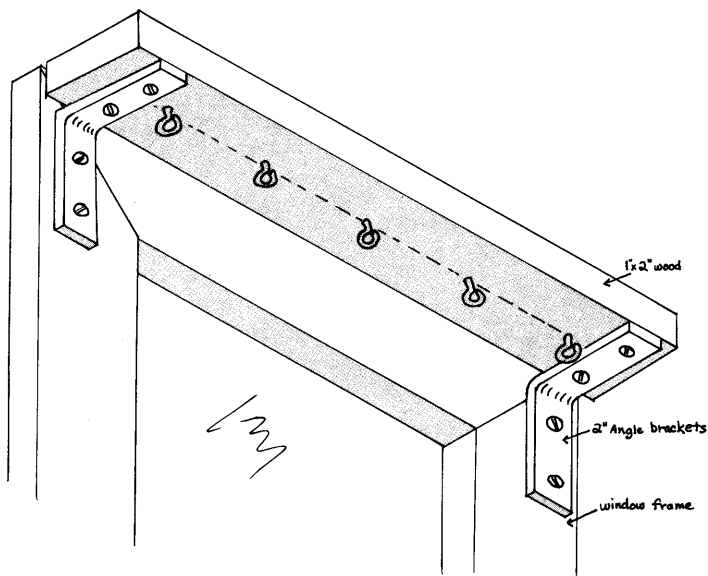
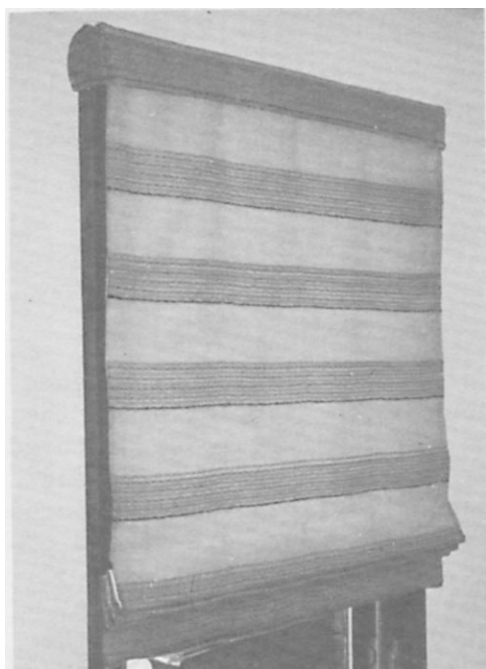

Fig. 5

Mount 2" (50 mm) angle brackets to window frame, setting them in about 1" (25 mm) from outside edge of window frame. See Fig. 5. Cut a 1" x 2" (25 x 50 mm) board the width of the window frame. Cover board with drapery lining using a stapler. Now place 1/2" (12.5 mm) screw eyes in board to line up with rows of rings sewed onto drapery panel. Fasten board to top of angle bracket with screws.

Adjust drapery panel to length desired and attach it to board with carpet tacks. Thread nylon cords through screw eyes and tie all cords together in a knot on side. Cut cords all the same length just below knot.

Place cleat at side of window or on side of molding for wrapping cord around when shade is raised.



The fabric for the valance is pieced at corners and lined. Tack valance onto board to hide end of board and brackets.

Materials needed:

- 1" x 2" (25 x 50 mm) board - width of window (lumber yard)
- steel rod - width of window (hardware)
- 2 angle brackets with screws (hardware)
- 40 - 1/2" (12.5 mm) plastic rings (hardware or drapery department)
- 5 screw eyes (hardware)
- approximately 32 yards (29.4 m) nylon cord (not heavy cord used for traverse drapes) (drapery department)

Plate 2
Roman Shade by Maxine Wendler



Romni Wools and Fibres Limited

3779 West 10th Avenue
Vancouver, B.C., Canada V6R 2G5



Write for our FREE catalogue on our large selection of spinning and weaving equipment.

Sturdy Drum Carder \$95. in kit form.

22" Table Loom \$160. in kit form. Folds flat like a suitcase while warp is on.

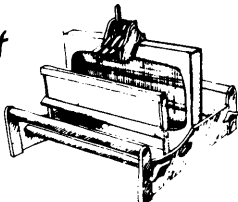

Book Reviews

KUME HIMO TECHNIQUES OF JAPANESE PLAITING by Jules and Kaethe Kliot. Some Place Publications, Berkeley, CA, 1977, 20 pp.

Anyone interested in braids, whether Japanese, Peruvian or other, will treasure this monograph. The authors first explain the importance of braids in the Japanese culture. There is a clear description of the tools and materials and how they are used. The instructions on how to make one's own tools and braids are clear and well illustrated. The system for diagramming braids used in the book can be applied to other ethnic braids and opens the way to exciting explorations.

Clotilde Barrett

THE VERTICAL LOOM - PRINCIPLES AND CONSTRUCTION by Jules Kliot. Some Place Publications, Berkeley, CA, 1976, 12 pp.

The contemporary tapestry weaver prefers to build his own loom because he can adapt it more easily to his own methods of working and his space limitations. This book will be of great help to him because it includes the materials and plans for several types of upright looms. The author explains the function of all the parts of the loom; this is helpful when the builder needs to make adjustments to suit his own needs.

Clotilde Barrett

BATTENBERG AND POINT LACE TECHNIQUES, STITCHES AND DESIGNS FROM VICTORIAN NEEDLEWORK, Edited by Jules and Kaethe Kliot. Some Place Publications, Berkeley, CA, 1977, 22 pp.

Today, Battenberg and point lace are of greater interest to the lace collector than to the craftsman. As this book is a compilation of several publications it would have been useful to the collector if references had been cited and a bibliography included. For the craftsman, the description of a large number of needle point lace stitches is valuable although bad reproductions, repetitions and omissions are indications that this is not an instruction manual.

Clotilde Barrett

TAPESTRY LOOM. TECHNIQUES by Jules Kliot. Some Place Publications, Berkeley, CA, 1974, 24 pp.

This is a small instruction manual that contains all the basic information for tapestry weaving providing one has a loom already set up. The technique includes flat tapestry, chaining, pile weaving, soumak, loops and laces. It is useful as a textbook for classes and also as a compact reference book for any tapestry weaver.

Clotilde Barrett

SPRANG - LANGUAGE & TECHNIQUE by Jules Kliot. Some Place Publications, Berkeley, CA, 1974, 16 pp.

A concise instruction manual on sprang, which is a technique of intermeshing and/or frame plaiting a warp. By using a special set of symbols the author drafts and explains complex manipulations and leads the reader quickly to intricate structures.

There is a lot of information contained in these 16 pages.

Clotilde Barrett

GROWING HERBS AND PLANTS FOR DYEING by Betty E. M. Jacobs, Select Books, Tarzana, CA, 1977, 126 pp.

The book starts with "First, you ought to read this introduction"! How very true. It tells exactly what this text is about. The book contains the following information on thirty dye plants listed alphabetically: botanical name, botanical family, other names, life span, habitat, appearance (beautifully illustrated), cultural requirements and propagation, when to harvest for dyeing, how and which parts of the plant to use, material to be dyed, mordant, color-fastness.

The section on the dye procedure is equally well planned and to the point. It includes equipment, chemicals, the preparation, and the process of dyeing.

The book also lists a source of supply for plants and a limited bibliography.

One does not need to have a patch of land ready for growing plants to enjoy this book. The information contained herein will be appreciated by all the advocates of vegetal dyeing, the novice as well as the expert.

Clotilde Barrett

ANNOTATED DIRECTORY OF SELF-PUBLISHED TEXTILE BOOKS by Elyse Sommer, editor. Sommertime Publications, P.O. Box E, Woodmere, NY 11598, 16 pp. \$1.25.

In recent years, some of the most informative textile publications have been self-published efforts, yet many of these remain unknown to the book buyer because they remain basically unadvertised. We are grateful to the editor of this booklet for listing, cataloguing, and reviewing all the books that have come to their attention. Textile craftsmen should support their effort by sending them recommendations for inclusion in future editions.

Clotilde Barrett

FREE AND EASY SPEED WEAVING by Louise Green.

FELT MAKING FOR THE ARTIST by Louise Green. Both booklets (7" x 5¼") are published by Greentree Ranch Wools, Loveland, CO, 1978, 24 pp. \$1.50 each.

The first text is a guide to produce simple decorative woven pieces. Children, teenagers and hobbyists will find easy to follow instructions to complete projects. The writing is simple and well illustrated.

The second text is of special interest because there is very little information available on felt making. The author introduces the fiber craftsman to a new approach of cloth construction. The instructions are easy to read and to follow and lead to interesting finished projects.

Both booklets contain the same chapters on dyes and dyeing. The information on dyeing is handled with a naivete that could very well prove harmful. Readers should be warned that all chemical dyes contain toxic material.

Clotilde Barrett

A BOOK OF PATTERNS FOR HANDWEAVING by John Landes, Southern California Handweaver's Guild, Inc., Hollywood, CA, 96 pp. \$5.50.

Landes's original pattern book dating from the Revolutionary period is in the collection of the Pennsylvania Museum. Mary Meigs Atwater bought it to the attention of contemporary handweavers in 1925 and supplied the drafts for the patterns. The patterns lend themselves to Summer and Winter, double weave, and overshot. Two of the patterns require a 2-tie-down weave different from Summer and Winter.

The book is a great inspiration for those who like to design with blocks. We all are grateful to the Southern California Handweaver's Guild, Inc. for making these patterns available again.

Clotilde Barrett

FABRIC COLLAGE by Anna Ballarian, Davis Publications, Inc. Worcester, MA, 1976, 80 pp.

Fabric Collage has been a viable folk art for centuries in such diverse parts of the world as Persia and South America, particularly among the San Blas and Huichol Indian tribes.

This book briefly explores the cultural influences on contemporary fabric collage as an art form, and then goes into some detail on how to use design sources in nature to inspire original design.

The book is plentifully illustrated with black and white photographs. There is a refreshing 8 page color section where some of the black and white illustrations are repeated in beautiful color.

There is a brief section on organization of equipment and materials, and a short look into creative new directions to explore.

This seems a particularly good resource for teachers of art and design, and could be helpful to anyone needing help in basic design interpretations.

Ellen Champion

EARLY AMERICAN WEAVING AND DYEING - THE DOMESTIC MANUFACTURER'S ASSISTANT AND FAMILY DIRECTORY IN THE ARTS OF WEAVING AND DYEING by J. and R. Bronson, Dover edition, New York, NY, 1977, 204 pp. \$3.50.

In the handweaver's literature there are many references to this Bronson book, first published in 1817. I am most grateful that this landmark work has been republished.

Rita J. Adrosko's introduction to this Dover edition is a great help in interpreting this early 19th century handbook.

"Early American Weaving and Dyeing" is most interesting from a historical viewpoint. The authors describe the equipment they use, the yarn calculation for the cloth that they manufacture, the preparation of yarns, and the dressing of looms. However, the hints aimed at domestic manufacturers of the 19th century are often of value to today's handweaver.

There are 35 drafts, many of which are 5 or 6 harness designs based on what is called today "spot Bronson".

The second half of the book deals with pre-aniline dyes. It opens a field of experimentation to the contemporary dyer.

There are also 10 pages of recipes for various products used in the early 19th century household.

This is a truly valuable book for weavers who are curious about the state of the craft 150 years ago.

Clotilde Barrett



Andean Crossed-Warp Techniques for Decorative Trims Part II - Tubular Bands

by Adele Cahlander Drawings by Ann Houston

Tubular bands are often used in Bolivia for colorful straps and ties. They are also frequently used as edge-bindings on small bags and larger flat textiles. In this case, there is a needle on the spiralling weft, so the band is attached as it is being woven, as described in *The Weaver's Journal*, April '77. Of the five variations of "tubes" identified in our book, "The Art of Bolivian Highland Weaving," Tube 5 is the most exciting. It has crossed and diverted warps, which produce colorful diamonds in a "snake-back" effect. It can be varied in color, in the number of warps used, and in the amount of twist in the warps. These twists resemble *2-strand warp twining*, with frequent changes in the direction of the twist.

Preparing the Warp. A special way of winding the warps will be described, in which knots are avoided and the far end has uncut loops, so both ends can have a finished effect. Although only three colors are needed, directions are for five colors: blue (B), red (R), white (W), green (G), and yellow (Y).

The figure-8 bouts can be wound around your finger and a post. If you use two posts, use the near one merely to stabilize your finger, which should be held in a *horizontal* position, like the near beam on a primitive loom. (The near post will be useful later to hold the warp when you install heddles.) The warp is to be wound in ten figure-8 bouts in this order: B RWR GG YWY B.

To start winding the warp, take hold of the blue yarn in your left hand, at least a yard from its end (to use later as *weft*). Secure it by winding it around your baby finger and use your thumb to keep it in place on your left (horizontal) forefinger. Wind the yarn in a figure-8 bout, returning *under* your left finger and up under your thumb, leaving the yarn uncut. Put the B ball down at the right *beyond* the remaining balls of yarn. Grasp the ends of the other four yarns (R, W, G and Y) and insert them as a group toward the left, on top of and parallel to your left finger, under both blue yarns, as a *color core*. (See Fig. 1. To simplify the drawing, only two other colors are shown instead of four.) With your left thumb holding the yarns firmly in place on your left finger, lift the R ball from the *near* side of the B ball, to start it in the direction of making a figure-8 bout. At the same time, adjust the *holding turn* on your left finger (Fig. 3) by pulling the B yarn

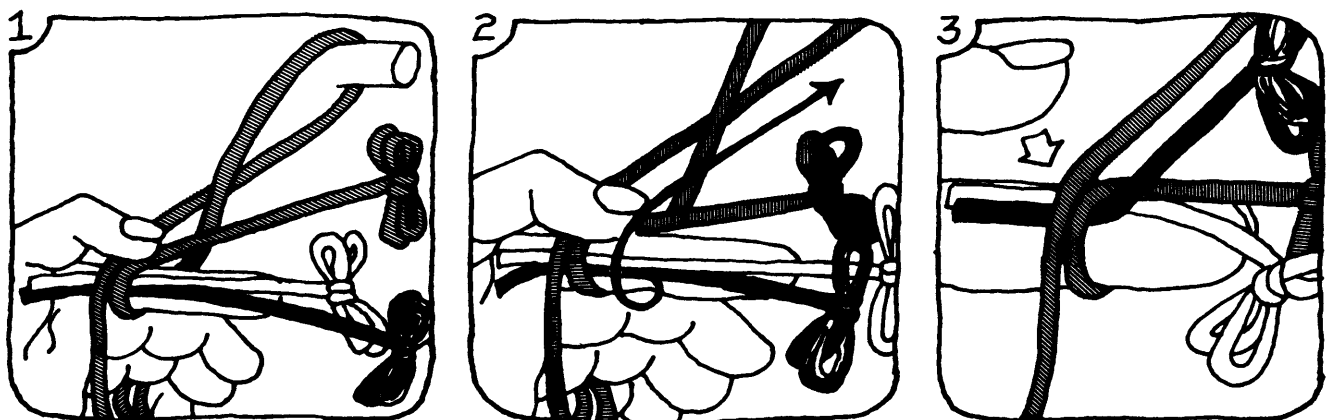

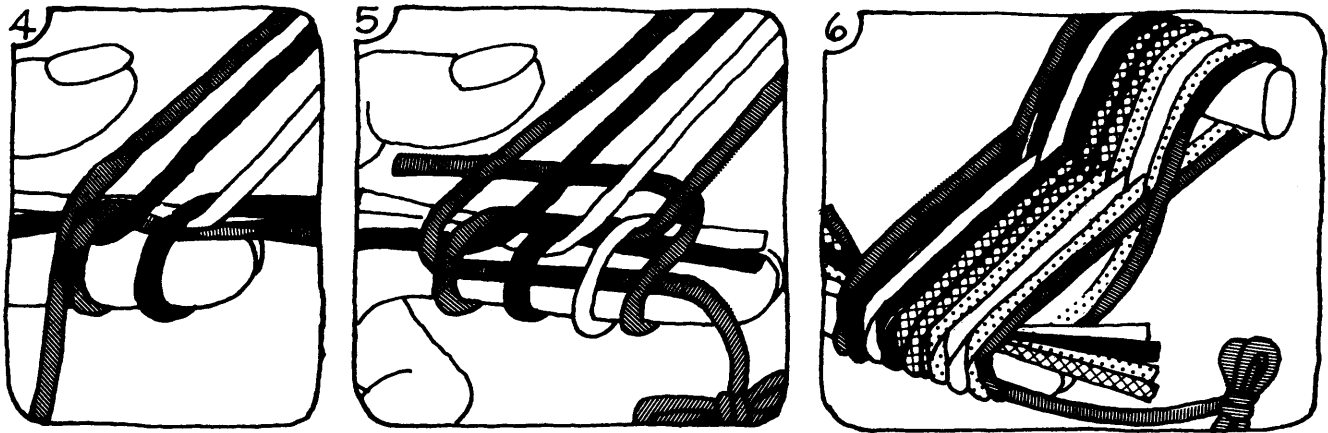

snugly toward the right on your finger, to join the core yarns. Wind a figure-8 bout with the R yarn. (Be sure to *pass under the core yarns extending out from your finger, for every return from the far post.*) Then place the R ball at the right *beyond* the core yarns. Taking the W yarn from the near side of the R yarn, make another holding turn under your thumb, and proceed to wind the W bout (Fig. 4). Continue in like manner for the other bouts (R GG YWY B), ending with the final B bout.

In the end-loop shed held open by your left finger, pass the beginning and final B ends in opposite directions. (For clarity, Fig. 5 shows only four warps). Your weft is now on the right side. Pull it snug and pass it under all the warps to pass it again left to right in the same shed, beginning the *spiral*. Tug at all the other ends to even their tension and cut them off about an inch long to be trimmed later. (OR, if yarns are slippery, tie the ends temporarily in a slip-knot, before cutting ends). Put these end-loops on the near post, or tie with a cord to your belt. Tie a cord around the far end-loops to secure them and to use later as a hanger-loop.

Original warp cross

B	R	W	R	G	G	Y	W	Y	B	far
B	R	W	R	G	G	Y	W	Y	B	near



Rearranged warp cross - DRAFT

B	R		R	G	G	Y	WW	Y	B	H2
B	R	WW	R	G	G	Y		Y	B	H1

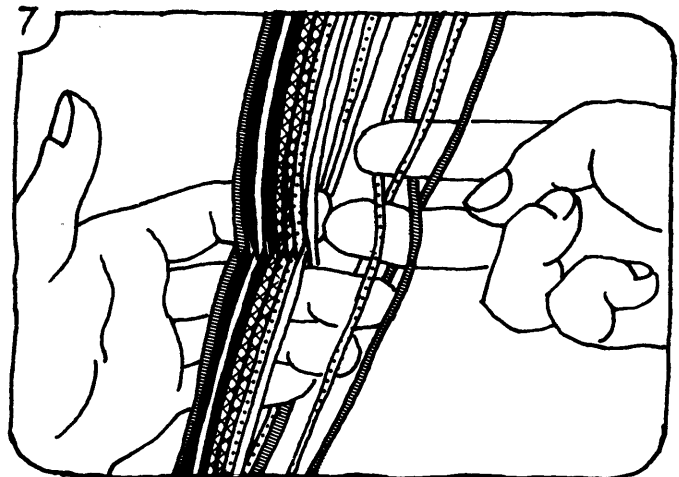

Find the original warp cross. With your left hand palm up, enter two fingers into the two sides of this cross, like lease sticks, and rearrange the warps onto two fingers of your right hand, according to the draft. Note that there is a pairing of the W warps, making the angle of the middle pairs of warps the opposite from those on the edges. Transfer rearranged cross to lease sticks.

Install Heddle 2 as a shed loop, and Heddle 1 as a multiloop heddle. (See next page for directions).

HOW TO MAKE HEDDLES
(Condensed from W.J. April 1977)

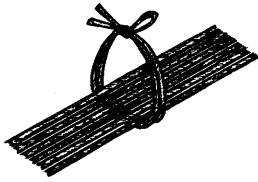

Lift warps above far lease-stick, and tie a cord around them for shed loop, Heddle 2.

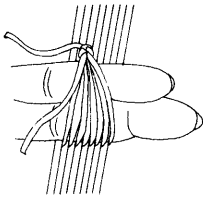

Tie ends of heddle string in a square knot above left fingers.

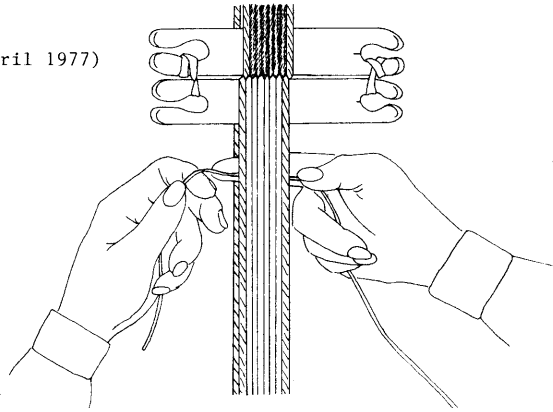

For Heddle 1, lift warps that are above near lease-stick, and insert heddle string under them from right to left.

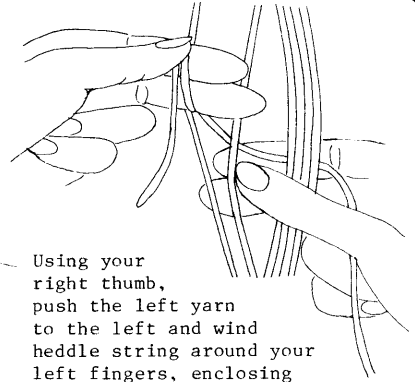

Using your right thumb, push the left yarn to the left and wind your heddle string around your left fingers, enclosing a single loop. Continue in order to right, a warp for each loop.

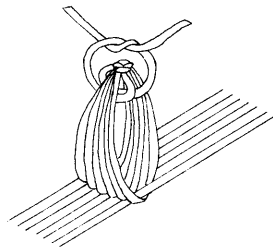

Bind loops firmly together by bringing ends through center of loops in opposite directions and tying very securely. Repeat.

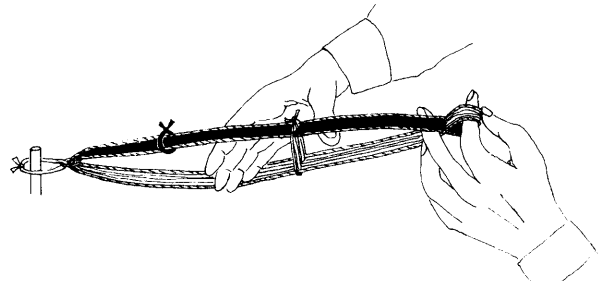

Check your heddles by lifting H2 to see if its warps can clear through Heddle 1. If not, correct.

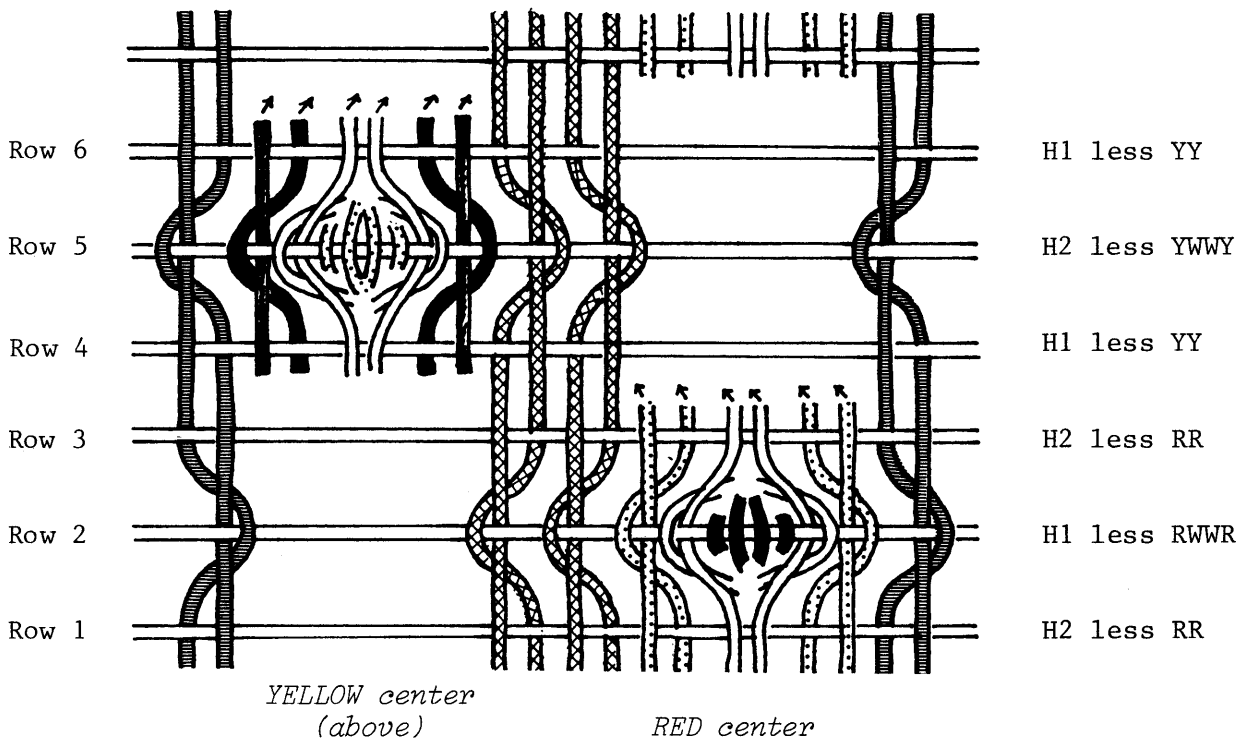

Weaving Sequence. Lift the warp off the posts, with the hanger-loop hung from a stable object, and your left forefinger in the near end-loops with the weft, which should be hanging on the right. There are six rows in this sequence, three for the diamond with the red center, and three for the diamond with the yellow center. To form the tube, you need to have a *spiralling weft*. For each new shed, beat, pull weft snug, and pass it *below* all the warps to the left side, so you can pass it in the new shed from left to right (→) every time. Pull the weft snug, and sharply twist the woven end toward the left in a A-twist to have yarns in proper position. (See next page for DIAGRAMS & CROSSES).

DIAMOND WITH RED CENTER

Row 1. Lift H2 (the shed loop) less two Red warps. Beat, and pass weft (→).

Row 2. With your left forefinger *in the shed with the weft*, lift H1 less RWWR, and insert your left middle finger for a picking cross. Slide your "lease fingers" forward a little. The six warps to be diverted (WRRRRW) should be hanging below. To make it easier to handle them, use two fingers of your right hand (palm up) to shift over the right-hand warps, splitting them between the paired WW warps on your left forefinger. From below, place the WRRRRW warps on your left middle (far) finger, in that order, then shift back the warps from your right fingers:

far finger	<u>B</u>	G	G	Y	WRRRRW	Y	B	The warps on the far finger are <i>keepers</i> ,	
near finger	B	G	G	Y	W	W	Y	B	but all need to be crossed, except the
									four R's for the center of the diamond.

Cross as follows: B→←G←G←W (RRRR) W→Y→B→ Beat, and pass weft to right (→).

Row 3. Lift H2 less RR. Pass weft (→).

DIAMOND WITH YELLOW CENTER

Row 4. Lift H1 less YY. Beat, and pass weft to right (→).

Row 5. With your left forefinger *in the shed with the weft*, lift H2 less YWWY, and insert your left middle finger for a picking cross. Slide your 'lease fingers' forward a little, and the six warps to be diverted (WYYYYW) should be hanging below. As in Row 2, split warps between the paired WW warps on your near finger, shifting all the right-hand warps to the right onto two fingers of your right hand (palm up). Place WYYYYW (in that order) on left far finger and shift warps back to left hand from right hand:

far finger	<u>B</u>	R	WYYYYW	R	G	G	B	Again, the keepers are the warps	
near finger	B	R	W	W	R	G	G	B	on the far finger, but all except
									four Y's need to be crossed.

Cross as follows: ←B←R←W (YYYY) W→R→G→G→←B. Beat, pass weft (→).

Row 6. Lift H1 less YY. Pass weft to right (→). (REPEAT).

Finishing. When there is no longer room to operate the heddle and shed cord, remove them. The unknotted end-loops lend themselves to various treatments, depending on the use of the tube. Often it is braided to the end, if it is to be stitched flat onto something. It may also be braided partway, and the small end-loop section used to snitch it onto the heading cord of a belt, or some object. For a button-hole effect, these small end-loops can be reinforced by wrapping or button-hole stitches. The end may also be made into a tassel.

Getting Acquainted with the Diagram. The centers of the tube's diamonds are composed of warps that are *diverted* from the opposite side of the tube. Other warps are crossed, to develop the diagonal lines of the design. This may be represented on a diamond grid (b), compared to plain weave (a). The direction of the cross, to right or left, is indicated by arrows, but soon you should be able to recognize what is needed, by looking at the position of the warps on your 'lease fingers'. (The number of empty diamonds is not meaningful).

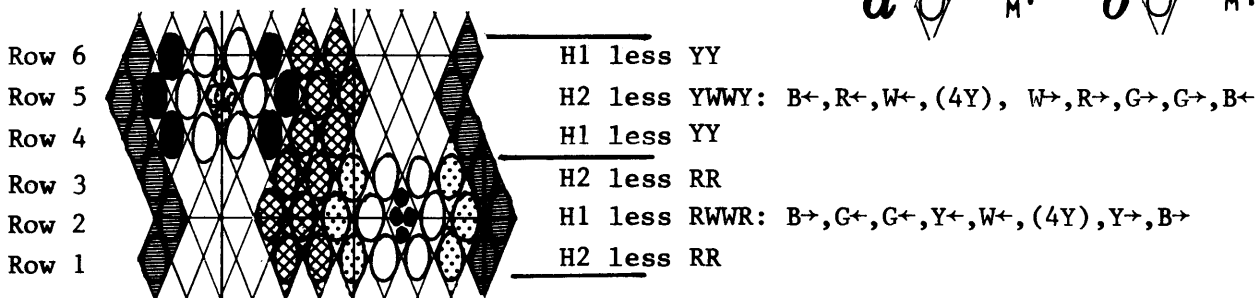
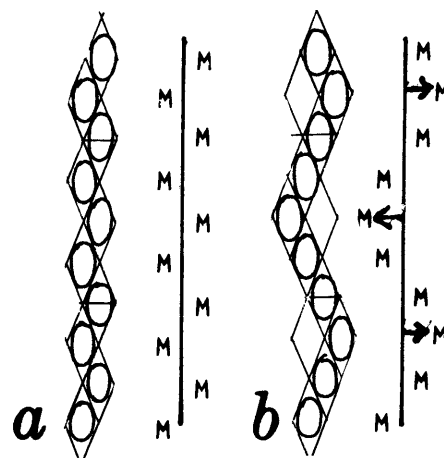

A. Six-Row Tubular Tie. (Same tube, with another type of diagram)

Row 6	B	R	WW	R	G	G	-	-	B	H1 less YY	
Row 5	B←	R←	<u>W← YYY →W</u>	→R	→G	→G	-	--	-	B←	H2 less YWY
Row 4	B	R	WW	R	G	G	-	-	B	H1 less YY	
Row 3	B	-	-	G	G	Y	YY	Y	B	H2 less RR	
Row 2	→B	-	--	-	G←	G←	Y←	<u>W← RRR →W</u>	→Y	→B	H1 less RWWR
Row 1	B	-	-	G	G	Y	YY	Y	B	H2 less RR	

DRAFT:

H2	B	R	WW	R	G	G	Y	WW	Y	B
H1	B	R	WW	R	G	G	Y	Y	Y	B

↖ start

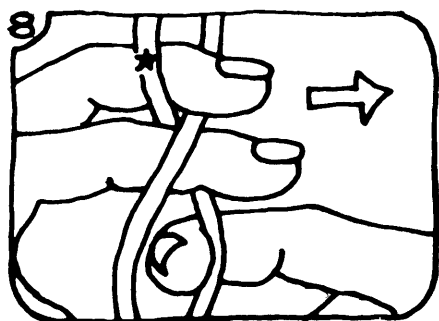

Making the Crosses
(from the picking cross on your lease fingers)
★ = warp to be kept

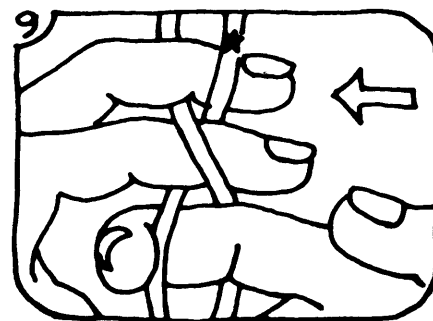

Cross toward the RIGHT (→).
Merely grasp the warp under your near finger, dropping its partner.

Cross toward the LEFT (←).
Move the warp slightly to the right on your near finger, so that you can reach down at its left to get its partner.

VARIATIONS

Most Bolivian examples of Tube 5 have an 8-row sequence, rather than one with six rows. Certain warps then have an *extra twist*, after being crossed in a previous row. This is represented by double arrows in the diagram, (→→) or (←←). You need merely to make a regular cross in the direction shown, from the picking cross. In the following row, another picking cross is needed and these warps then need to be *untwisted* a turn (<or>). Only Rows 4 and 8 of the sequence do not need picking crosses. Example B is good for trying this technique.

Row 8

Row 7

Row 6

Row 5

Row 4

Row 3

Row 2

Row 1

START:

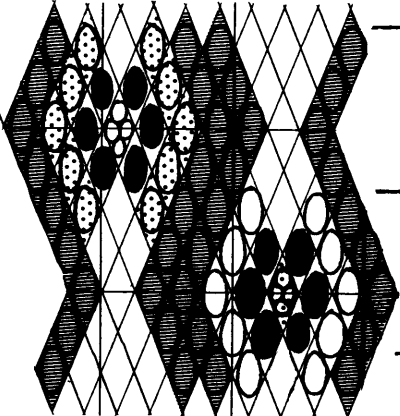

DRAFT:

H2	M	L	L	M	M	W	W	M		
H1	M	L	DD	L	M	M	W	DD	W	M

H2

H1 less WDDW: MLDDL, M<, M<, M>

H2 less WW: M←, L←, D←, (WWW), D→, L→, M→→, M→→, M←←

H1 less WDDW: MLDDL, M→, M→, M←

H2

H1 less LDDL: M>, MMWDDWM

H2 less LL: M→→, M←, M←, W←, D←, (LLLL), D→, W→, M→

H1 less LDDL: M→, MMWDDWM

H2 (Start)

B. Eight-Row Tubular Tie with More Twists. (Same tube as above)

Row 8	M	L	L	M	M	W	W	M	H2		
Row 7	M	L	DD	L	<M	<M	--	- M>	H1 less WDDW		
Row 6	M←	L←	D← WWW →D	→L	→→M	→→M	-	- M←←	H2 less WW		
Row 5	M	L	DD	L	→M	→M	--	- M←	H1 less WDDW		
Row 4	M	L	L	M	M	W	W	M	H2		
Row 3	<M	-	--	-	M	M	W	DD	W	M	H1 less LDDL
Row 2	→→M	-	-	M←	M←	W←	D← LLLL →D	→W	→M	H2 less LL	
Row 1	→M	-	--	-	M	M	W	DD	W	M	H1 less LDDL
START:	M	L	L	M	M	W	W	M	H2←(Start)		

Optional Drafts for Tube with Color Changes. With the same general format, try using three colors instead of four, as in the first draft below. After several inches, rearrange the warps as shown in the second draft, installing the new heddle and shed loop. The previously-used heddle and loop can be pushed to the back, to be re-used later. To match the color between the diamonds, use an M weft first, then a W weft for the second draft. Change colors every several inches.

M W W M M W W M M W DD WM M W DD W M	H2 H1	W M M W W M M W W M DD M W W M DD M W
---	----------	--

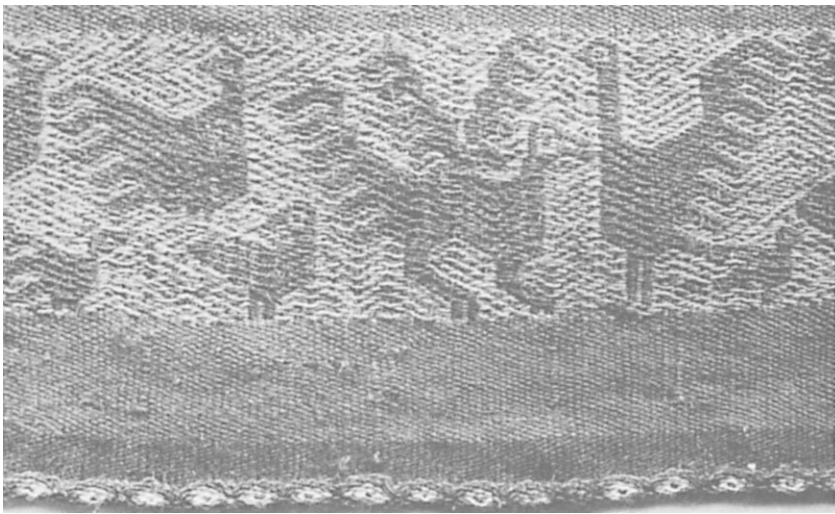

*Bolivian tubular edge-binding
with crossed and diverted warps*

C. Four-Color Tube with many color changes

It is fun to have many possible changes of color combinations, using only eight figure-8 bouts, two in each of four colors. For each change, the warp needs to be rearranged, and a new heddle and shed loop installed. Try storing your previously used heddle and loop in back for possible later use. Remember to change your weft each time to match the color between diamonds. For smoother transitions, plan for minimal changes in warp order each time. Here are two drafts you might use for a beginning:

Combination I:

L	L	M	W	W	M	H2		
L	DD	L	M	W	DD	W	M	H1

Weft: M

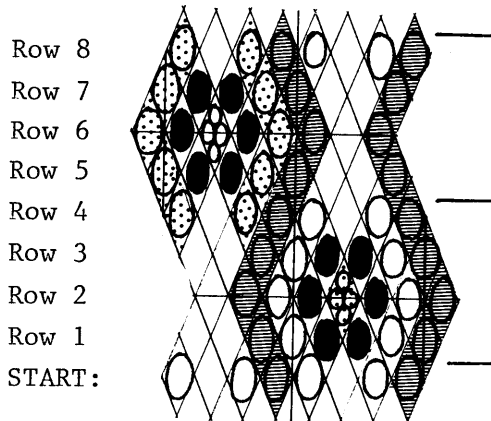

Row 8 — H2
 Row 7 — H1 less WDDW: LDDL, M<, M>
 Row 6 — H2 less WW: L<, D<, (WWWW), D>, L>, M>>, M<<
 Row 5 — H1 less WDDW: LDDL, M>, M<
 Row 4 — H2
 Row 3 — H1 less LDDL
 Row 2 — H2 less LL: M<, W<, D<, (LLLL), D>, W>, M>
 Row 1 — H1 less LDDL
 START: — H2 (Start)

Combination II:

L	W	W	L	M	M	H2		
L	W	DD	W	L	M	DD	M	H1

Weft: L

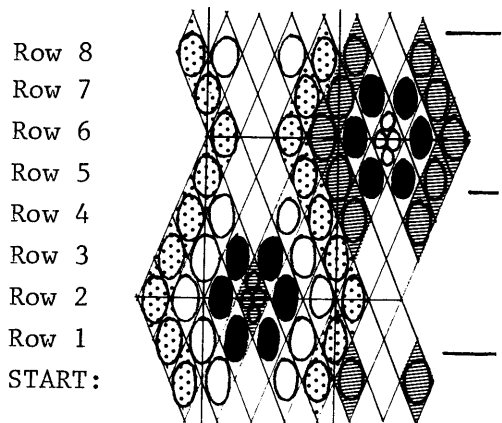

Row 8 — H2
 Row 7 — H1 less WDDW: L<, L>, MDDM
 Row 6 — H2 less WW: L>>, L<<, M<, D<, (WWWW), D>, M>
 Row 5 — H1 less WDDW: L>, L<, MDDM
 Row 4 — H2
 Row 3 — H1 less MDDM
 Row 2 — H2 less MM: L<, W<, D<, (MMMM), D>, W>, L>
 Row 1 — H1 less MDDM
 START: — H2 (Start)

D. Tubular Edge-Bindings

Tube 5 is a favorite for binding edges of bags and larger flat pieces or garments. The weft must be on a needle so that it is attached as it is being woven. (This process was described in detail in *The Weaver's Journal*, Vol. I, No.4).

On the edges, where the tube will be joined to the cloth, there are fewer crossings, since there is less need for the long diagonals there. A great variety is possible in number of warps and in combinations of color.

DRAFT:

B	W	W	M	L	L	B	H2		
B	W	DD	W	M	L	DD	L	B	H1

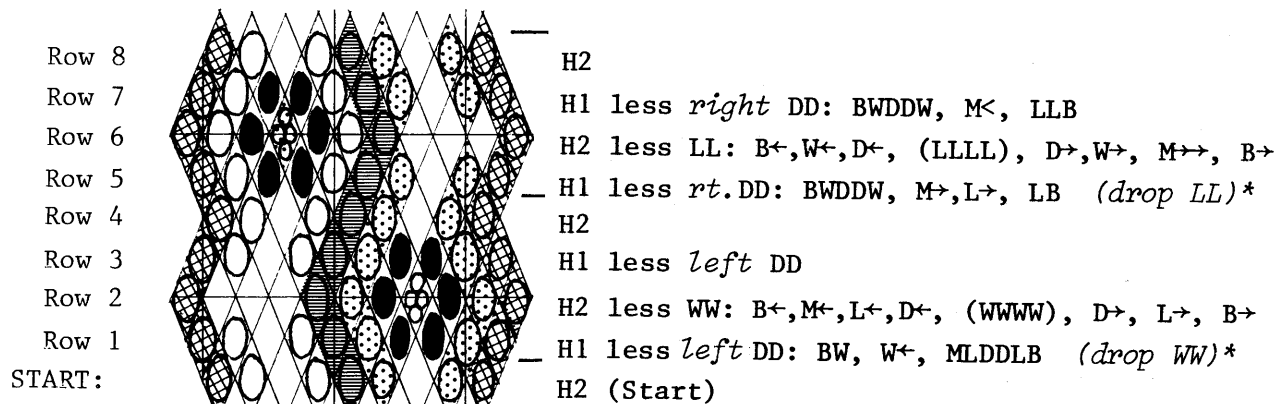
* (*Drop after weft is passed*)

Yarns to Use. Many kinds of yarn work well for weaving these tubes, finer or coarser, depending on their use. My scissors cord with many color changes was made from Knit-Cro-Sheen crochet cotton; a silk cord (dyed with natural dyes by Cheryl Kolander) is great for necklaces. Try short samples.

Some ways to use Tube 5: an eye-glass case with a tubular edging of Parisian cotton, a silk necklace, and a scissors cord of Knit-Cro-Sheen crochet cotton, woven with many color changes.

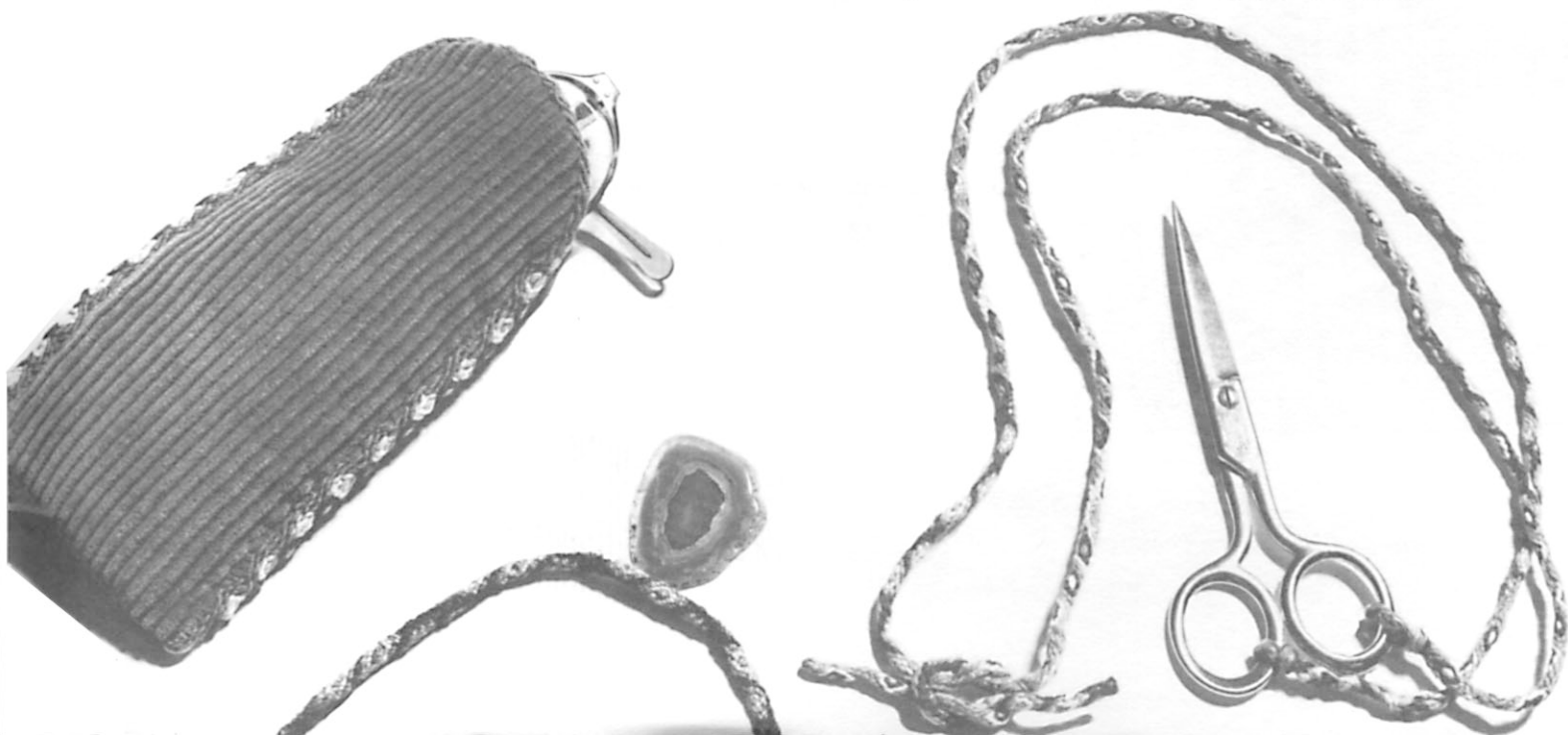

Woven Swing

A woven swing is fun and decorative in almost every room of the house or outdoors. It can be made to fit any color scheme and furniture style. It gives that very personal touch that makes your home environment so special. Plate 1 illustrates a very elegant swing. It is all white.

The yarns are heavily textured and combine rayon, wool and mohair. The weave is a balanced plain weave sett at 10 e.p.i. (40/10 cm).

Besides your handwoven yardage you will need the following hardware:

- One 18" (46 cm) diameter very thick plywood disk in which $\frac{1}{2}$ " (12.5 mm) holes are drilled as shown in Fig. 1.
- One $\frac{1}{2}$ " (12.5 cm) nylon braided rope, 32" (81 cm) long.
- 5' (152 cm) furniture upholstery blind tacking strip, $\frac{1}{2}$ " (12.5 cm) wide.
- 5' (152 cm) upholstery welt.
- Glue.

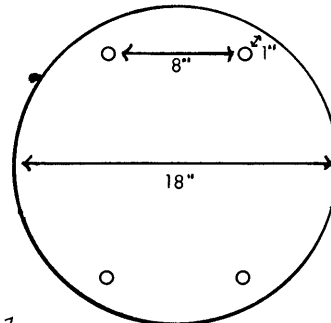

Fig. 1

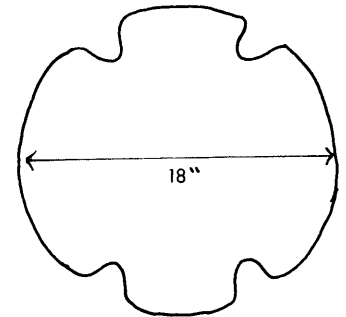

Fig. 2

Weave 2 yards (183 cm) of fabric 20" (51 cm) wide (finished width). With it, cover the top of the plywood and make a flat shaped pillow as shown in Fig. 2.

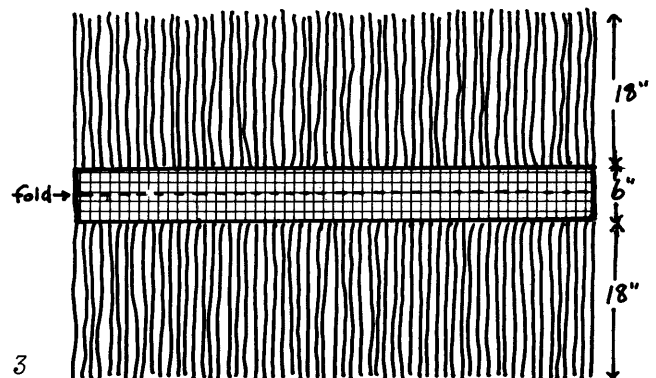

Fig. 3

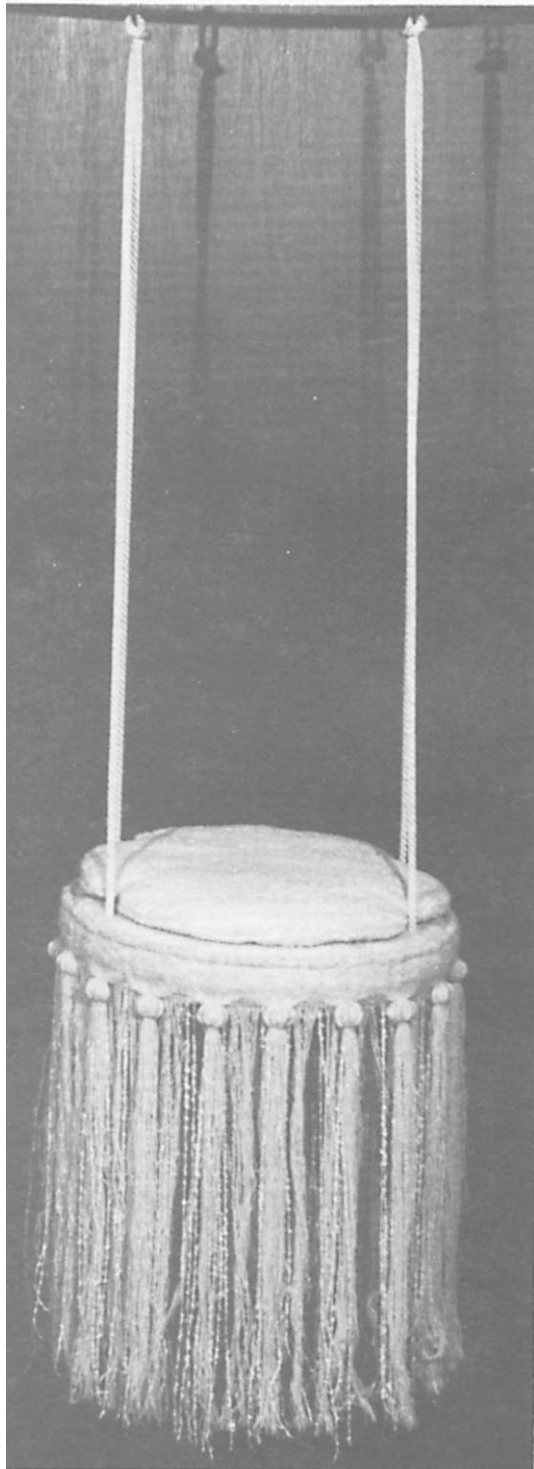

Plate 1
Woven Swing designed and woven
by Iris Richards

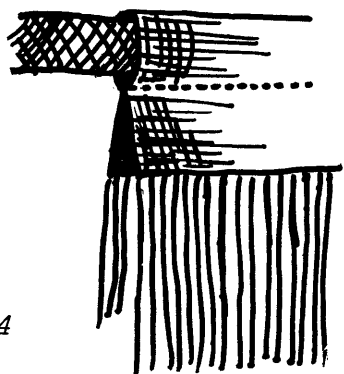

Fig. 4

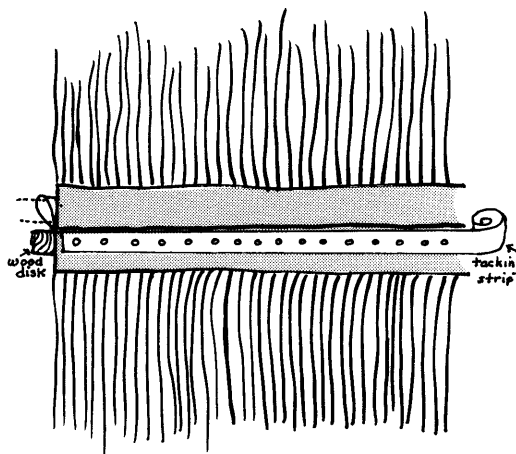

Fig. 5

Make a strip of woven cloth 5' (152 cm) long and 6" (15 cm) high with 18" (46 cm) of warp fringe on top and bottom. (See Fig. 3.) Sew it to form a tube that fits exactly around the wooden disk (Iris Richards wove this part of the swing tubular, on the loom). Fold the tube and encase the welt. (Fig. 4)

Unfold the tube, wrong side out. Slip the tube over the wooden disk and tack the lower half onto the wood with the aid of the tacking strip. Fold the upper half back to cover the strip.

The outer layer of fringe was decorated with yarn beads.



List of Advertisers

The Cotton Squares.....	p 30
Folklorico.....	p 2
Greentree Ranch Wool	p 3
Ruth Holroyd.....	p 11
J Made Looms and Weaving Accessories.....	p 47
Oregon Worsted Co.....	p 4
Katherine Ramus.....	back cover
Raye's Eclectic.....	back cover
Romni Wools and Fibres Limited	p 34
Skyloom Fibers.....	back cover
The Weaver's Shop.....	back cover
Weaver's Way.....	p 4

In contacting any of these advertisers, please mention that you saw their ad in "The Weaver's Journal".



Looms &
Weaving Accessories

*Beautifully Crafted,
Finest Quality Weaving Tools*

Floor Loom in
45" and 60"
weaving width.
Loom can be pur-
chased with four
harnesses and
extra harnesses
can be installed
at any time up
to a total of
twelve. Ex-
tremely heavy
construction.
Double warp beam available. Bench not included.

For further information on this or any of our
other fine products, write:

Dealer Prices Available



LOOMS & WEAVING
ACCESSORIES

P.O. Box 452
Oregon City, Oregon 97045
(503) 631-3973 or (503) 659-4330

100% VIRGIN WOOL WORSTED
Hand Weaving Yarn



Maypole
Willamette
 or *Nehalem*

- Weaving and Warping
- Mothproofed
- Hand Washable

"Willamette" offers:
 52 Colors
 2 Ply, 2 oz. net
 Approx. 700 yards per tube

"Nehalem" offers:
 52 Colors
 3 Ply, 2 oz. net
 Approx. 270 yards per tube

Available at your local
 Weaving Supply Shop

OREGON WORSTED CO.

P. O. Box 02098, Dept. K

Portland, Oregon 97202

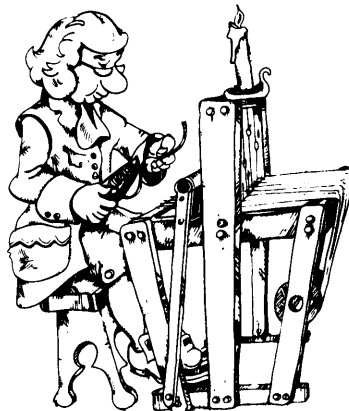

- Looms
- Yarns
- Books
- Work-Shops
- Spinning Supplies
- Macrame Materials

For unique yarn samples send \$1.00 and a self-addressed stamped envelope to:

The Weaver's Shop & Yarn Co.

39 Courtland Dept. WJ
 Rockford, Michigan 49341
 Phone: 616-866-2531

"Opening The Door to Fiber"
 edited by Raye



Class projects and new ideas. 6 guest articles, 20 pages, 12 projects, 9 full color pages.

Suggested retail \$1.95.

Wholesale only
 Minimum order - 2 dozen.

Raye's Eclectic Craft Yarns, Inc.
 8157 Commercial St.
 La Mesa, CA 92041.



Supplier for the
 Fiber Arts
 1905 South Pearl
 Denver, Colorado 80210
 777-2331

weaving spinning
 knitting basketry
 crocheting batik
 dyeing macrame
 instruction books

an ALTERNATIVE for the
 COLORADO WEAVER and
 CRAFTSPERSON

consignments
 hrs. 10:00 - 6:00 Tues.-Sat.

Corrections: TUBULAR BANDS, *The Weaver's Journal*, Vol. III No. 1
Cut and paste

p. 41, line 8....toward the left in a Z twist....

line 23 B←G←G←Y←W (RRRR) W→Y→B→

p. 42, line 16, row 2, B→,G←,G←,Y←,W←,(4R), W→,Y→,G→

A. Six-Row Tubular Tie. (Same tube, with another type of diagram) p. 42

Row 6	B	R	WW	R	G	G	-	-	B	H1 less YY	
Row 5	B←	R←	<u>W← YYYYY →W</u>	→R	→G	→G	-	--	B←	H2 less YWWY	
Row 4	B	R	WW	R	G	G	-	-	B	H1 less YY	
Row 3	B	-	-	G	G	Y	WW	Y	B	H2 less RR	
Row 2	→B	-	--	-	G←	G←	Y←	<u>W← RRRR →W</u>	→Y	→B	H1 less RWWR
Row 1	B	-	-	G	G	Y	WW	Y	B	H2 less RR	

Tube C Combination I p. 44

H2
H1 less WDDW: LDDL, M<, M>
H2 less WW: L←, D←, (WWWW), D→, L→, M→, M←
H1 less WDDW: LDDL, M→, M←
H2
H1 less LDDL
H2 less LL: M←, W←, D←, (LLLL), D→, W→, M→
H1 less LDDL
H2 (Start)

Tube C Combination II p.44

H2
H1 less WDDW: L<, L>, MDDM
H2 less WW: L→, L←, M←, D←, (WWWW), D→, M→
H1 less WDDW: L→, L←, MDDM
H2
H1 less MDDM
H2 less MM: L←, W←, D←, (MMMM), D→, W→, L→
H1 less MDDM
H2 (Start)

Tube D p. 45

H2
H1 less *right* DD: BWDDW, M<, LLB
H2 less LL: B←,W←,D←, (LLLL), D→,W→, M→, B→
H1 less *rt.*DD: BWDDW, M→,L→, LB (*drop LL*)*
H2
H1 less *left* DD
H2 less WW: B←,M←,L←,D←, (WWWW), D→, L→, B→
H1 less *left* DD: BW, W←, MLDDL (drop WW)*
H2 (Start)

* (*Drop after weft is passed*)