

The Weaver's Journal

\$2.50

JANUARY 1979

VOLUME III NUMBER 3

ISSUE 11





Looms &
Weaving Accessories

*Beautifully Crafted,
Finest Quality Weaving Tools*

Floor Loom in
45' and 60'
weaving width.
Loom can be pur-
chased with four
harnesses and
extra harnesses
can be installed
at any time up
to a total of
twelve. Ex-
tremely heavy
construction.



Double warp beam available. Bench not included.

For further information on this or any of our
other fine products, write:

Dealer Prices Available



**LOOMS & WEAVING
ACCESSORIES**

P.O. Box 452
Oregon City, Oregon 97045
(503) 631-3973 or (503) 659-4330

Introducing
**GLOOR
TRI-WEAVER**

A TOTALLY NEW LOOM
FOR
MANUAL WEAVING
OF
TWO AND/OR THREE THREAD
FABRICS

*"Buy Tri-weave!
Your ravel won't travel!"*

Information - Write or call

GLOOR Inc.  Aurora Ohio
Box 305 44202
216-562-6021

List of Advertisers

The J. & H. Clasgens Co.....	p. 4
The Cotton Squares.....	p. 28
Gloor Inc.....	p. 2
Holroyd, Ruth.....	p. 21
J Made Looms and Weaving Accessories.....	p. 2
Oregon Worsted Co.....	p. 13
Oy Varpa-Looms Ltd.....	p. 13
Ramus, Katherine.....	p. 37
Romni Wools and Fibres, Ltd.....	p. 23
Schacht Spindle Co., Inc.....	p. 3
Skyloom Fibres.....	back cover
The Weaver's Journal Publications.....	back cover
The Weaver's Market.....	p. 46
The Weaver's Shop & Yarn Co.....	back cover
Weaver's Way.....	p. 25

The Weaver's Journal

Quarterly Journal For Textile Craftsmen
Volume III, Number 3, Issue 11 January, 1979

Table of Contents

List of Advertisers.....	2
Letter From the Editor.....	4
Fashion Show of Handwoven Garments.....	5
Utilitarian Hang-up by Ruthe Nelson.....	11
Raw Silk Reeling by Mary Derr.....	12
Woven Fringes.....	14
Recipe For a Neutral Soap by Joan Lee Walsh.....	17
Loom Controlled Designs.....	18
Simple Patterns For Handwoven Garments.....	24
Sprang and Frame Plaiting For Garments.....	26
The Collection.....	30
Crackle.....	32
Japanese Shopkeeper's Coat.....	40
Book Reviews.....	41
Poncho by Doris Hurt.....	44
The Weaver's Market.....	46

Editor and Publisher - Clotilde Barrett
Associate Editors - Mary Derr and Maxine Wendler
Copy Editor - Earl Barrett
Staff Artist - Ellen Champion
Advertising Manager - Jeanne Richards
Circulation Manager - Iris Richards
Promotion Director - Willy Bottema
Photography - Earl Barrett and Ellen Champion

The Weaver's Journal is published on the first of each January, April, July and October at 1900 55th Street, Boulder, Colorado 80301. Telephone (303) 449-1170. Subscription rates are \$9.50 U.S. Currency, for 1 year (4 issues) or \$17.50 U.S. Currency, for 2 years (8 issues). (Colorado residents add 3½% sales tax). Outside U.S.A. 1 year \$11.50 U.S. Currency, for 2 years \$20.00 U.S. Currency. Copyright Colorado Fiber Center, Inc. 1978. Second class postage paid at Boulder, Colorado 80302. The editorial committee takes no responsibility for the goods advertised in this journal.

Cover Photo: Sprang shrug made by Ellen Champion, modeled by her daughter Carol.
Photo by Ellen Champion

NEW FLOOR LOOMS



Available in
36" and 42"
Weaving Widths

Free Brochure

**SCHACHT SPINDLE
COMPANY, INC.**



P.O. BOX 2157
BOULDER CO 80306

Letter From the Editor

Weavers get a great deal of satisfaction from making garments. Selecting the yarns, finding the right dress patterns, working out the design, weaving the cloth and finishing the fabric are the main steps that have to be taken in anticipation of the day when the cloth will become a wearable garment. Finally the moment comes when the finished handwoven fashion is sold to a client or is shown off to friends and relatives. Many of these garments are masterpieces. This happens when all the factors are well integrated, the garment is comfortable to wear, exciting to look at and has great tactile qualities. These outfits become lifetime favorites.

On the other hand, it happens too often that the project has an unhappy ending. After the garment has been tried on just once, the excitement has gone away and the piece of clothing is tucked away in the closet. One realizes that the fabric was too stiff, too bulky, too warm, too sleazy, too itchy. One notices that the seams are too bulky, that they begin to fray. One wonders why handwovens give that 'broad side-of-the-barn look' instead of a flattering, elegant air. Almost all weavers could tell a few of these sad stories.

Well, we at *The Weaver's Journal* would like to be of some help in making your next project more successful.

As we did last year, we are featuring 'fashions' again this year in the January issue of *The Weaver's Journal*. All the garments illustrated and described in this issue have proven to be successful, fun to make and easy to wear.

We hope that these projects give you ideas that can be adapted to your needs and that from now on, only masterpieces will come off your looms.

We thank our subscribers who have given us permission to publish the descriptions of their garments. We hope that all of you will continue to share ideas about rewarding weaving projects.



THE J. & H. CLASGENS CO.

New Richmond, Ohio 45157

Since 1862

Manufacturers and Dyers of Woolen and Worsted YARNS

for Weaving, Knitting, and Crocheting

Yarns made of domestic, foreign, Icelandic karakul, mohair and other specialty wools

We also offer raw wools, wool roving and top

Antique bobbins and shoe lasts

We sell direct from our factories, passing the savings on to you.

Fashion Show of Handwoven Garments



Ken models the shirt woven by his mother Clotilde Barrett

This painted warp fabric using fiber reactive dyes on silk was woven for the article "Silk Dyeing" in *The Weaver's Journal*, Vol. III No. 2.

The sections of warp for the four basic pattern pieces (sleeves, front and back) were painted and woven consecutively. The end of the warp was left unpainted for the facing and the collar.

Tussah silk from Robin and Russ was used for warp and weft. The weave is a balanced plain weave. The fabric was sett at 15 epi (60/10 cm) and finished by washing it in hot water and drying it in the dryer. This resulted in 20% shrinkage.

The shirt pattern is a modified version of Butterick 3625.

~~~~~



Silk dress by Ellen Champion

This dress was designed to wear with a turquoise necklace.

The silk yardage was woven in plain weave, with bleached tussah silk from Coulter studios sett at 15 epi (60/10 cm).

The fabric was pre-washed and then the sections corresponding to the belt, the lower 1/3 of the sleeves and skirt were dyed with turquoise fiber reactive dye.

Dye process: soak the cloth for 15 minutes in:

- 2 t procion dye
- 2 gal. lukewarm water and water softener
- 9 T salt

Add 3 T washing soda and soak for 15 minutes more.

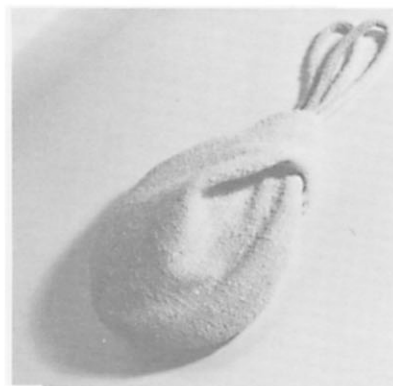

The fabric was then allowed to drip upside down for a short time so that the color would gradually fade out in the undyed portion. The fabric was then washed, pressed and made into a dress using Vogue pattern 7202.

The matching evening bag is sewn with Vogue pattern 1981.

*Evening bag
by Ellen Champion*



Silk blouse by Susan Snover

Pure silk yarns of various sizes and textures are combined to weave this loom shaped garment.

WARP: three different weights of warp were threaded randomly.

WEFT: a fine noil silk used threefold

SETT: 16 epi (64/10 cm)

WEAVE: plain weave with areas of pick-up leno.

CONSTRUCTION: The garment was woven in rectangular pieces with warp threads dropped to form the neckline and armholes.

The rectangular-shaped sleeves were set in the square armholes following instructions for

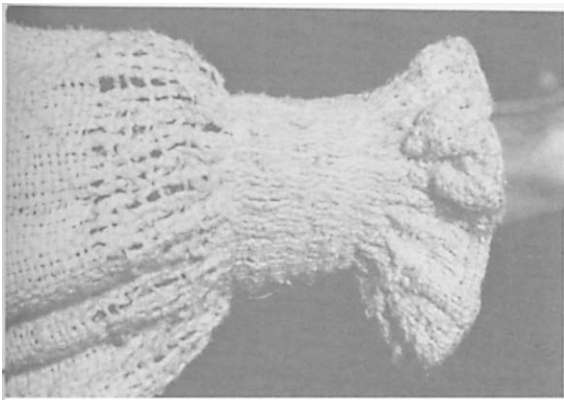

Detail of silk blouse woven by Susan Snover

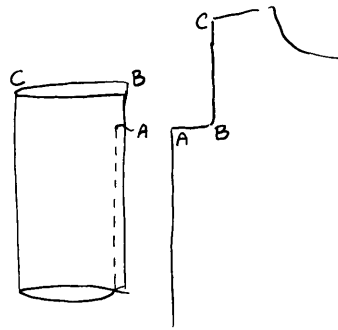

making a peasant blouse by matching up points A, B and C as shown in the diagram.

Quoting Susan Snover: "Working with silk thread was a pleasure. It was easy to work with though some of the yarns were quite nubby and textured. The garment drapes softly and is comfortable to wear."



Ingrid models her dress woven by her mother Clotilde Barrett

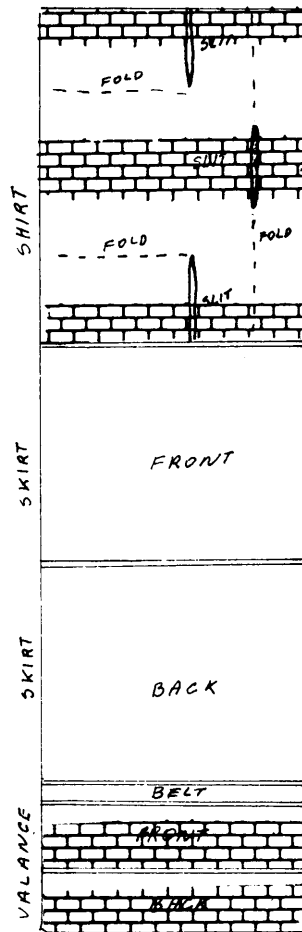

The top of the garment is a modified bog shirt. See instructions for weaving a bog shirt, *The Weaver's Journal*, Vol. III No. 1.

The skirt is made with dress pattern McCall's 5248.

The yardage on the loom was 42" (107 cm) wide and 4 yards (3.65 m) long. It was washed and dried in the dryer and shrank 15%.

WARP: tussah silk
 WEFT: tabby, same as warp
 pattern, silk, rayon blend
 SETT: 15 epi (60/10 cm)
 PATTERN: crackle weave, described on p.36 of this issue. The bog shirt was finished with a crochet edging that formed small buttonholes.



The Weaver's Journal

SHOP OWNERS

To sell single issues of "The Weaver's Journal" write to:

"The Weaver's Journal"
 1900 55th Street
 Boulder, CO 80301



The off-white mill end yarn used for this garment contains cotton, rayon and some silk. The warp was threaded on an 8-harness straight draw. The vest was woven in a broken twill and the skirt in plain weave.

WARP: fine 2 ply mill end yarn
 WEFT: same as warp
 SETT: 20 epi (80/10 cm)
 WIDTH IN THE REED: 40" (100 cm)
 TOTAL LENGTH OF THE WARP: 6 yards (5.5 m)

The yardage was finished by washing. Total shrinkage approximately 20%. The dress pattern is Butterick 5880.

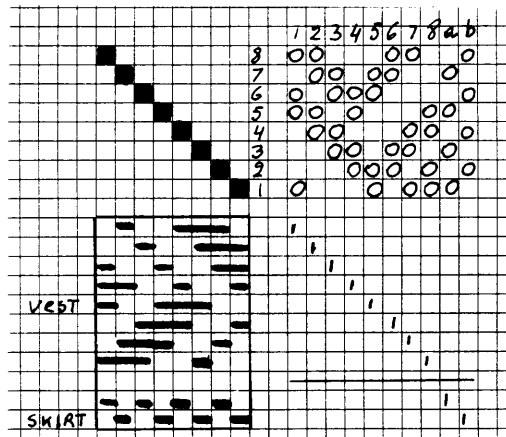

Skirt and Vest, in plain weave and twill by Maxine Wendler

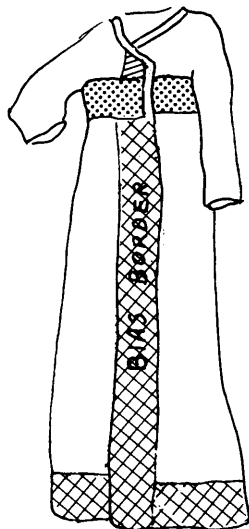

To really appreciate this 4-harness woven garment one should view it in color. Two different treadlings and three different color combinations were used to weave the fabric.

The piecing of the garment is accentuated with crochet trim of deep gold cottolin yarn. The ties are also crocheted using the same yarn.

-  { treadling A
gold weft
-  { treadling A
varied color weft
-  { treadling B
natural weft
-  { treadling A
natural weft

Housecoat woven in M's and O's by Barbara Knollenberg and modeled by Carmen San Juan



Detail of housecoat in M's and O's

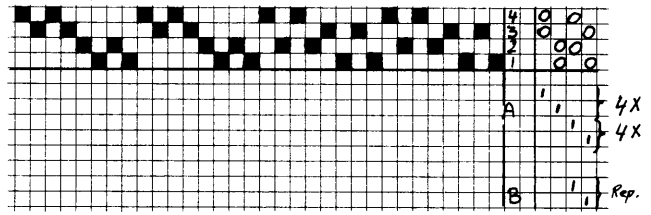

WARP: natural cottolin 22/2
 SETT: 30 epi



After weaving the yardage, the fabric was machine washed and dried using warm water and very little ($\frac{1}{4}$ normal amount) detergent.

The fiber content of Cottolin is cotton and linen which makes this garment useful and easy to care for.



Alpaca garment
 by Willy Bottema

Alpaca is the fiber for weavers who have to feel a fabric rather than look at it. This plain weave fabric has an exceptionally good hand and creates an aura of luxury.

WARP:  brown alpaca, single from Scott's Woolen Mills
 blond alpaca, single from Scott's Woolen Mills
 fine dark brown 2-ply wool worsted, used twofold, from Clasgens.
 SETT: 12 epi (50/10 cm)

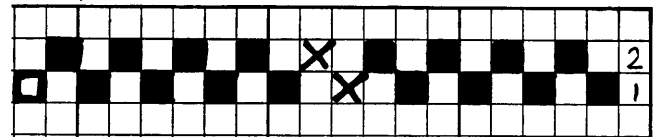

warping order

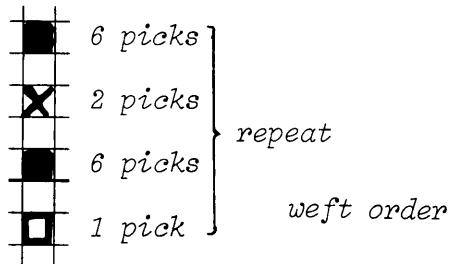

The yardage measured 28" X 3 yards (71 cm X 2.74 m) on the loom. The fabric was steam pressed at the dry cleaners without being washed.

The dress pattern is Butterick 5880 for the vest, Vogue 1733 for the skirt. A thin braid, using 3 strands of the alpaca was handsewn around the outer edges and the armholes of the vest.





Plate A

Plate B

Plate C

Three cotton tunics with overshot patterning by Louise Bradley

The job was to weave a garment that was to harmonize with a turquoise ring. Enough warp was wound to make three variations of an off-white cotton tunic with turquoise and green decorative bands in an overshot pattern.

WARP: unmercerized 2 ply cotton (mill end)
 WEFT: tabby - same as warp
 pattern - 2 ply colorfast tapestry wool
 SETT: 15 epi (60/10 cm)
 WEAVE: balanced plain weave with overshot bands
 THREADING: Rose Valley overshot

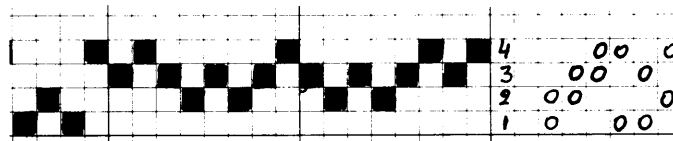

WIDTH IN THE REED: 28" (71 cm)
 FINISH: handwash in cold water, shrinkage, 10%
 DRESS PATTERNS: A modified pattern Butterick 5817
 B modified pattern Simplicity 8262
 C modified pattern Simplicity 6987

REMARKS: As the fabrics ravel easily, all the seams had to be finished. Keeping the fabric damp by spraying it with a 'plant mister' helps to control the edges during the sewing.



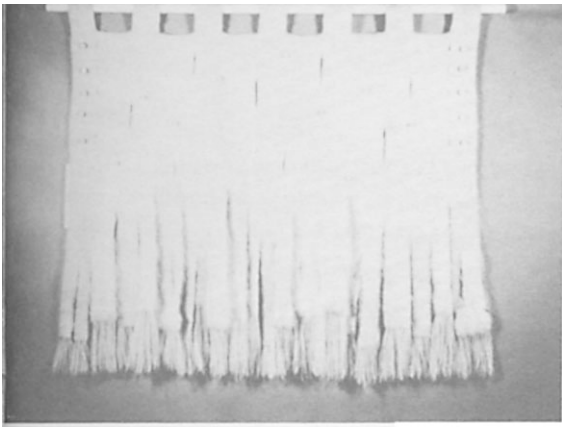

Utilitarian Hang-up

by Ruthe Nelson

For a show opening, I desperately needed a new skirt because the clientele were familiar with my others. It had to be handwoven, say so at first glance, and be a bit different to identify me as one of the 'artists'.

I decided that my skirt should double as a wallhanging as it seemed a shame to put time into a weaving and then relegate it to the back of a closet. The inspiration for this probably came from seeing Virginia West's beautiful skirt woven in wallhanging techniques and feeling that it should be on view and enjoyed at all times.

Time was short but I recalled the ease and simplicity of 'slits and tabs' as they were presented during a workshop by Glen Kaufman which I had recently attended. So I decided to pursue that technique and otherwise just show off the beauty of the luxurious yarn.

First I made a pattern with an old sheet to ensure that my design would fit around my hips. A problem arose: how to have it snug at both waist and hips, without darts, so that it also would lie flat against the wall.

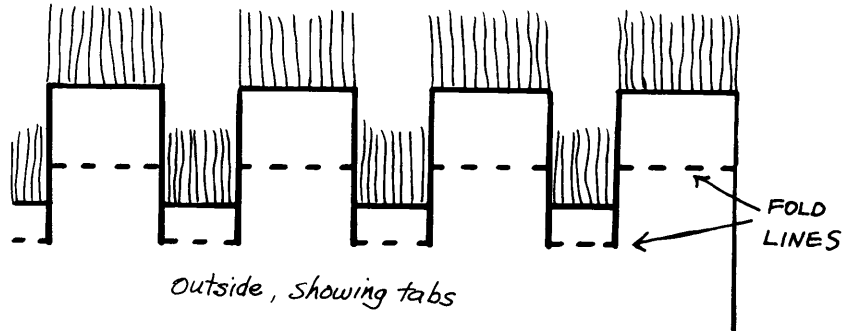

Fig. 1

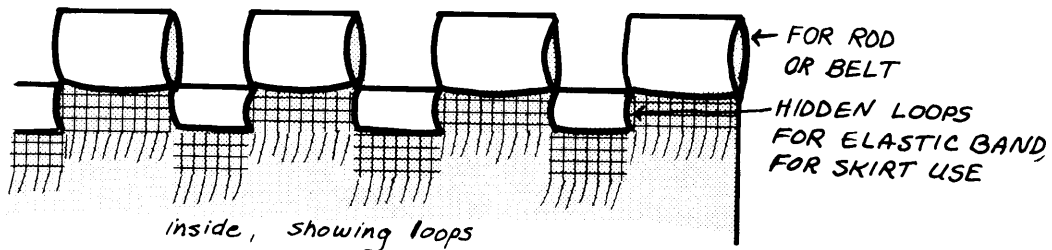

Fig. 2

~~~~~

The sketches of Fig. 1 and Fig. 2 show my solution. Large loops were created at the top for the insertion of a plastic rod while hanging, or a narrow alpaca belt when worn. These loops were made from long woven tabs, folded in half, and the ends were darned back into the skirt.

The areas between the large loops were woven into one inch (2.5 cm) tabs and folded down with the ends darned in. Through this hidden casing it was easy to insert a 3/4" (2 cm) elastic band with hooks and eyes on the ends, to rest on top of the hips when the piece was worn as a skirt.

Buttons seemed a necessity for a neat closure as a skirt, so antique pearl ones were put in rows on each side, and scattered throughout. They may be removed for washing as they are merely secured by stud hooks. Depending upon the occasion, one may button the side slit as high or as low as one wishes.

Technical details:

SIZE: 41" X 38" (104 X 96 cm)

WEAVE: simple tabby, 10 epi (40/10 cm)

WARP: alpaca which was unplied to make the fringe

WEFT: body - 2 ply handspun Bolivian alpaca  
tabs - handspun alpaca, mohair and Samoyed dog. These yarns were spun thin at the top, to thick at the bottom.

FINISH: washed Woolite, brushed with hair brush

The project is a sedate, simple wallhanging; it is also a crazy skirt. It is amazing how often it has been off the wall and on the body. It's such a happy piece to wear. Life is more fun and weaving more exciting, when one creates and solves problems.



# SILK

## *Raw Silk Reeling How to Do It Yourself by Mary Derr*

In the spring, when the mulberry trees are green with fresh leaves, the silk worms thrive. After gorging themselves on the leaves, each worm spins fibers which cover him, forming a cocoon. These fibers we know as silk.

Yarn is made from these fibers, either as thrown silk or spun silk. Raw silk is made by reeling selected perfect cocoons before the chrysalis emerges. To insure this, the pupae are stifled inside the cocoons. The cocoons are softened through the application of heat and water and then placed in a basin of hot water for reeling.

A worker takes the filaments of two, three or more cocoons, brings them together and carefully draws them out as a combined thread while the cocoons turn in the water. The silk thread is dried and wound into skeins about 30 inches (76 cm) long of uniform weight of 2.24 ounces (63.5 g). Thirty of these skeins form a 'book', 29 books are a bale of silk, the unit of raw silk transactions.

If you want to experiment with reeling silk for yourself, put six to eight cocoons into a small bowl of boiling water. Turn them over and over with a straw or small brush. Turn the heat down but keep the water hot during the entire process. Pick up the loose ends of the silk filament. By unreeling these, the cocoon's coarser outside fiber will be removed from the cocoon. These fibers will be set aside for spinning. As soon as the loose ends of the continuous smooth filaments are found, they are held in the hand, pressed together between the fingers and wound onto a smooth spool or a niddy-noddy. Work with patience and gentleness as this operation requires a certain amount of skill. The filaments of the most inner layers of the cocoon cannot be reeled because they are weak and consist of short fibers. When you reach that point, remove the pupae from the cocoon. This part of the cocoon can be used for spun silk. The single fiber of a cocoon is fine as a spider's web, but when it is unwound with fibers from other cocoons, the filament which is cemented together with sericin is thicker. This fiber should not be degummed until after it has been woven.

~~~~~

Come to Finland and have an unforgettable holiday in

VARPAPUU SUMMER WEAVING SCHOOL

2 two-week sessions in July, 1979, in Kouvola.

Weavers and craftsmen from all over the world.

New school, new looms, inspiring international atmosphere.

Come with family or friends!

Write for information (enclose \$1, for air mail):

OY VARPA-LOOMS LTD.
Mrs. Kilkka Hirvi
Kenraalintie 4 B 6
46800 Myllykoski, FINLAND

tel. 951/56594

100% VIRGIN WOOL WORSTED
Hand Weaving Yarn



Maypole
*"Willamette
or Nehalem"*

- Weaving and Warping
- Mothproofed
- Hand Washable

"Willamette" offers:
52 Colors
2 Ply, 2 oz. net
Approx. 700 yards per tube

"Nehalem" offers:
52 Colors
3 Ply, 2 oz. net
Approx. 270 yards per tube

Available at your local Weaving Supply Shop

OREGON WORSTED CO.

P. O. Box 02098, Dept. K

Portland, Oregon 97202

Woven Fringes

Surely, a weaver can find 1001 uses for woven fringes. If an afghan is not quite large enough, if a garment needs a decorative edging, if a bedspread looks too plain, these problems can usually be solved by weaving an extra fringe.

Many techniques for fringemaking give good results. The craftsman has to choose the one best suited for his project. The following fringes are all derived from a woven tape.

Single or double fringe in plain weave (Fig. 1)

Thread the warp for the fringe on harnesses 1 and 2 and thread two (or 4) additional warp threads on harness 1 and 2 at a distance equal to the length of the fringe. When the tape is taken off the loom, pull the additional warp threads out. The fringe may be looped or cut.

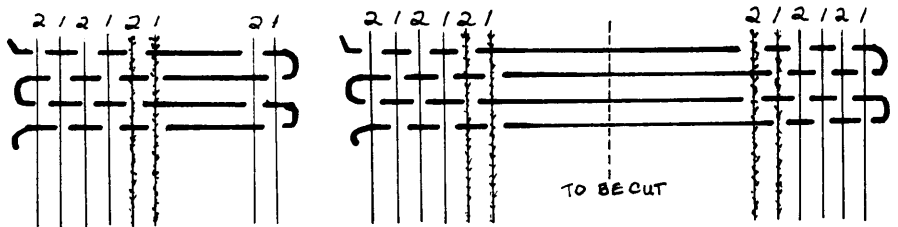

Fig. 1

Two cut fringes may be woven at once. The tapes have to be threaded at a distance of twice the length of the fringe.

The warp tends to unravel on the side of the fringe. Therefore these two outer warp threads should be of a special 'gripping' yarn such as chenille.

A leno technique may be used to stabilize the fringe tape and prevent the outer warp from unravelling.

Pick-up leno: with harness 1 up, pick up the first thread of the lower layer and bring it upward, see Fig. 2. Put the pick-up stick on edge and pass the weft through the shed. Lift harness 2 and weave plain (ref: Pick-up Leno, a Two-harness Loom Technique, *The Weaver's Journal*, Vol. III No. 2 pp. 3-7).

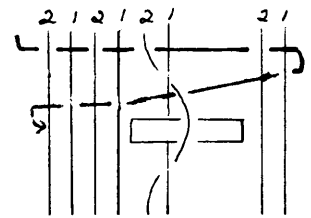

Fig. 2

Doup leno (See Fig. 3): Thread the outer warp end on harness 3 (or leave it unthreaded when using a 2H loom). Attach a doup on harness 1, pass it under the outer warp thread and catch the second one. Weave by alternating H1 and H2 (ref: Doup Leno *The Weaver's Journal*, Vol. III No 2, pp. 32-33).

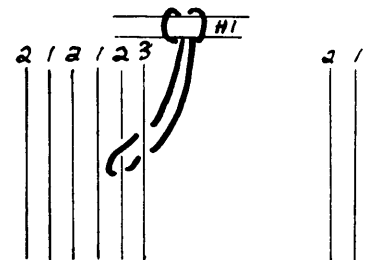

Fig. 3

Braiding the fringe will also prevent the outer warp from sliding.

The tape can be stabilized at regular intervals by not allowing certain weft picks to weave fringe (see Fig. 4).

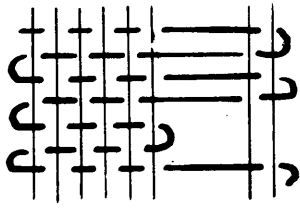

Fig. 4

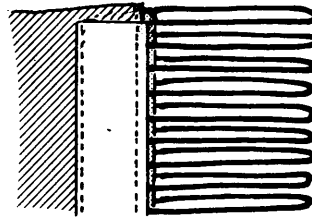

Fig. 5

The uncut double tape may be folded and sewn on as a loop fringe seam binding (see Fig. 5).

Fringes woven with two or more shuttles

A heavy weft is chosen for the fringe and the tape is woven by alternating the heavy and a fine weft. The weaving of such a fringe is more rhythmical if the shuttles are thrown from opposite directions.

For a double fringe, each tape requires its own shuttle carrying the fine weft.

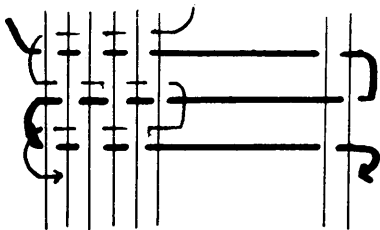

Fig. 6

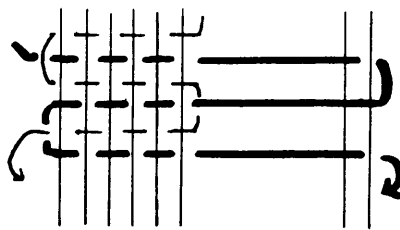

Fig. 7

Fig. 6 - both wefts are thrown in the same shed.
Fig. 7 - the weft is woven pick and pick.

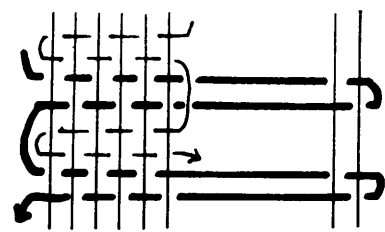

Fig. 8

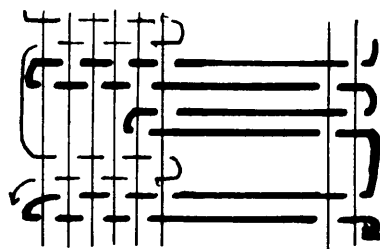

Fig. 9

Fig. 8 - the weft is woven in weft-way stripes.
Fig. 9 - a thicker fringe results from adding weft picks in the fringe area.

Picot

Picot is basically a short fringe. It can be ornamental or it can serve as eyelets for lacing two pieces of cloth together. (See Fig. 10).

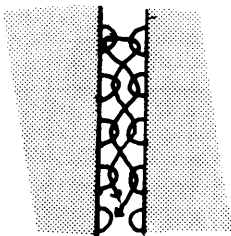

Fig. 10

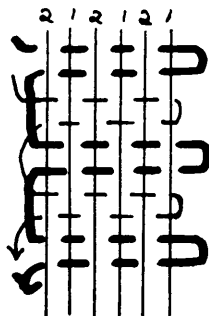

Fig. 11

Fig. 11 - flat picot on a 2-harness loom.

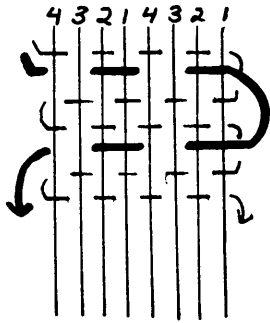

Fig. 12

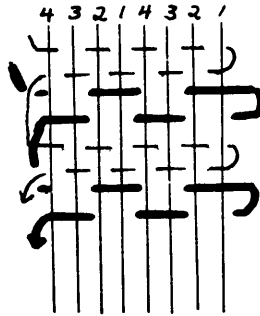

Fig. 13

Fig. 12 - flat picot on a 4-harness loom.
 Fig. 13 - twisting picot on a 4-harness loom.

Fringes with patterned tape

Patterned tapes causes an additional problem because a patterned weave often produces bad selvages. Nevertheless it is important that the edge of the tape opposite the fringe have a good selvedge.

Fig. 14 shows a twill tape-fringe. The middle 9 warp ends are threaded and woven as a 5 harness $\frac{2}{3}$ point twill. Such a tape would give bad selvages, therefore a warp end on H6 has been added on each side. H6 is lifted for every other pick; this insures that it will always be wrapped by the weft.

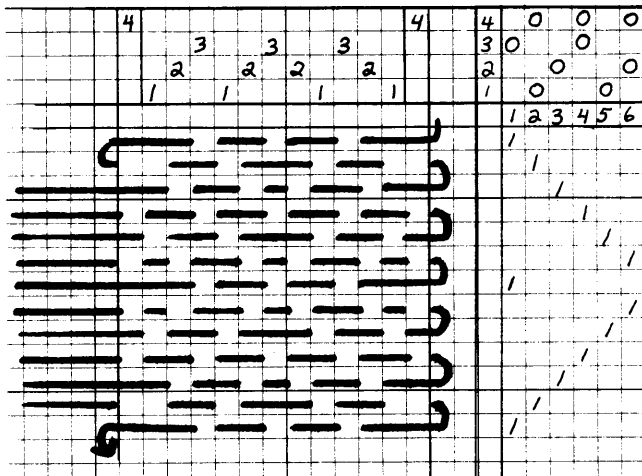

Fig. 15

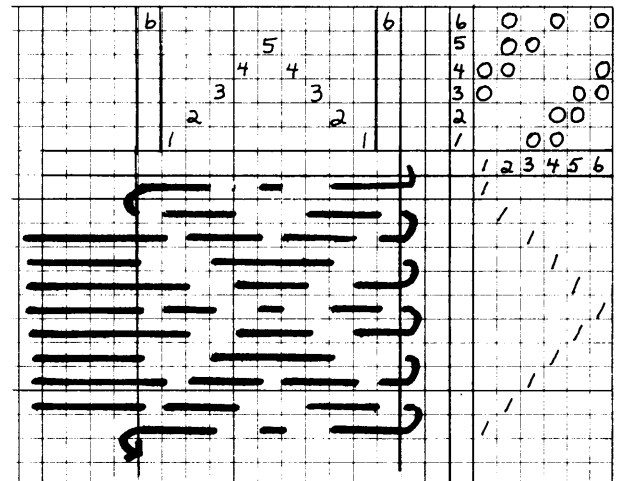

Fig. 14

Fig. 15 shows a 4-harness fringe based on a 3-harness point twill. Every so often the weft should be returned without making a fringe to prevent the outer warp on the fringe side from sliding.

Overshot fringes

The same precautions have to be taken as for twill to insure a good selvedge. The tabby background holds the warp of the tape secure.

Rya knot fringe

Set up a narrow warp on the loom. Weave the tape in plain weave. Cut even lengths of fringe yarn, $\frac{1}{2}$ " (12.5 mm) longer than twice the length of the fringe desired. After each $\frac{1}{4}$ " (6.25 mm) of woven tape, tie a sideways rya knot (larks-head) over the two middle warp threads as shown in Fig. 16.

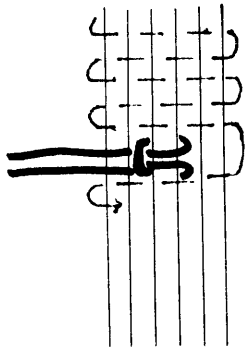

Fig. 16

When the tape is woven, fold it in half and sew onto a garment as if it were seambinding.



Recipe For a Neutral Soap

by Joan Lee Walsh

The finishing of handwovens often calls for a good *neutral soap*. This is especially true for silk. Joan Lea Walsh uses the following recipe which she wants to share with all.

You will need:

A flat wooden box	1 can lye (94-98% Sodium Hydroxide)
A 6-quart (5.7 liter) enamel bowl	10 lbs. (4.5 kg) unrendered fat or 5 lbs. (2.25 kg) pure lard or tallow
A smaller enamel bowl (about 2 qts. or 2 liters)	6 oz. (170 g) Coconut oil
Cheesecloth	
1 lb. (454 g) Olive oil	

Also, rubber gloves, a large wooden spoon, a thermometer, standard measuring spoons and cups, and a scale.

(Warning: Lye burns the skin. If you get any on you, rinse the area thoroughly with lots of water).

Good soap is neutral with no free fat or lye present. Test with pH papers. (Available at the drug store).

Directions:

1. Put the wooden box in the bath tub to soak.
2. Render the 10 lbs. fat to tallow.
3. To 5 lbs. (2.25 kg) cooled rendered fat, add 1 qt. (950 ml) water and heat gently. Strain through 6 layers of cheesecloth into a large enamel bowl. Add 1 lb. olive oil to the fat. Cool to 125°F (52°C)
4. Slowly pour 13 oz. (1 can or 368 g) lye into a separate enamel bowl containing 5-7 cups (1135-1585 ml) of cold water. (You must pour the lye into the water!). Cool it to 90°F (32°C)
5. Pour the lye solution (90°F) slowly into the fat (125°F), stirring it steadily until the mixture is thick and creamy (from 10 minutes to an hour). Add 6 oz. coconut oil. Stir thoroughly. Test pH. It should be 7.0.
6. If the mixture is separating, put the pan on a low flame and bring it to a boil. Add 1 qt. (946 ml) water and stir steadily. Be careful. It boils over easily. You can beat it with an egg beater if desired. Or stir until it drops from the spoon (wooden) in thick sheets.
7. Line the soaked box with a wet cloth and spoon or pour the soap in it.
8. Let it dry 4 - 8 hours.
9. Remove soap from box and cut into bars and store it where the air can circulate around each bar. Store for 4 - 8 weeks. This is the curing process.



Loom Controlled Designs

These are the notes on which Clotilde Barrett based her lecture at Convergence '78 in Fort Collins, Colorado.

Let's not try to turn weavers into robots but rather show how loom-controlled designs give the weaver artistic freedom and stimulate creativity.

One can approach a loom as if it were some kind of a minimal computer designed to accept a weaving draft. However, it should be kept in mind that a loom does not weave by itself but that the cloth is produced by a team, consisting of the weaver and the loom operating together.

Before dressing the loom one has to work out the program and the data. The data involves the choice of yarn, color, texture, the dimension of the work. The program involves the draft. However, the loom has limitations and this leads us to the study of weaves which are best adapted to loom-controlled designing. One has to learn to minimize the impact of the limitations of the loom while figuring out the draft best suited for a particular concept.

When we approach fiber art through loom controlled design, it is also important not to forget the options of hand manipulation during and after the weaving.

Except for the draw loom and the Jacquard loom, one cannot control each warp end of a fabric structure. Rather, one controls the rising and sinking of harnesses on which many warp ends are threaded. This number is very limited; that creates a fundamental limitation for the design. Another limitation stems from the fact that the weaver has to program the loom for interlacements of warp and weft which produce useable cloth.

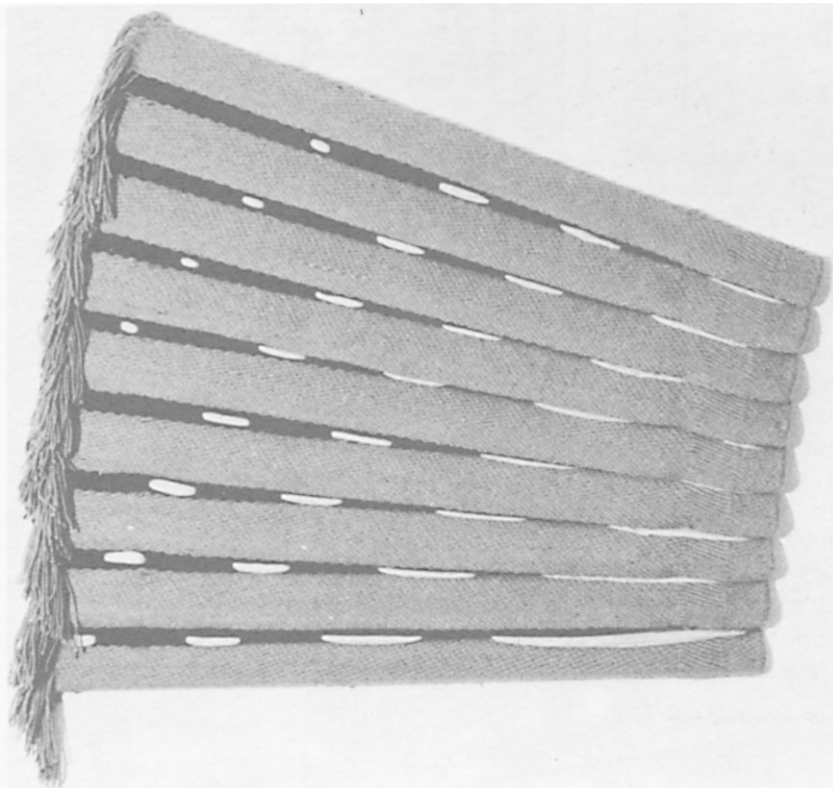

The programming involves *designing* while allowing for choices of material and color and keeping in mind the limitations of the loom. This brings us back to the very basics in art: *designing is working out an idea*. In the case of loom-controlled designs, the idea can be inspired by the visual or tactile effects of certain weave structures such as the ridges produced by cord weaves, the pile produced by corduroy, the openness produced by leno, the play of light as it is captured in satin weaves.

The wallhanging illustrated in Plate 1, in which the warp runs horizontally, is a large, exaggerated cordweave.

*Plate 1
Corrugation by Clotilde Barrett*

This weave structure was used to create the idea that corrugated material casts intriguing shadows. The ridges were accentuated by stuffing them with bent metal strips. The wallhanging was squeezed together at one end to emphasize the articulation of the ridges.

In loom controlled designs, the idea can also be based on structuring with modules. These modules are units of interlacement of warp and weft which are set off against units of different interlacements, different colors, different texture. These modules are best suited for building geometric forms.

Plate 2 illustrates "a mathematical game" published in Scientific American. Square modules have been arranged into heptominoes (composition of seven squares sharing at least one side). These heptominoes are interlocked as a puzzle.

The simplest module is the interlacement of two warp ends and two weft picks is plain weave. This is the module of double weave cloth.

Designing with modules for the loom requires skill in drafting with blocks and the knowledge of weaves which are particularly adaptable to this system and to the number of harnesses available. It is also important to study the color limitations and the special visual effects that each weave is capable of producing.

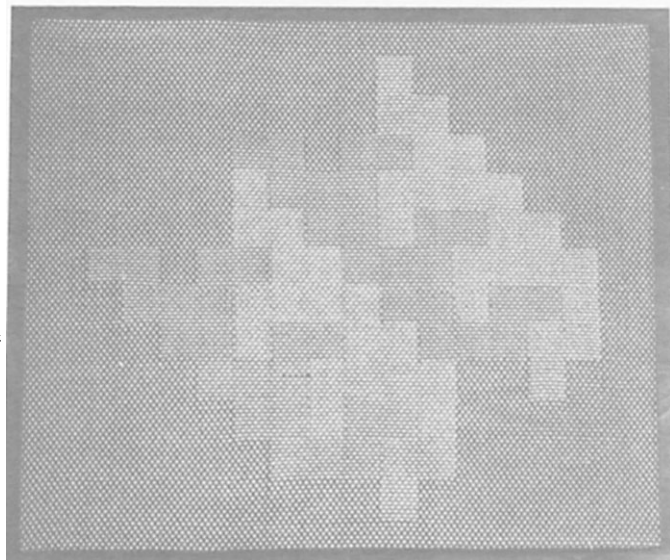

Plate 2
Wallhanging by Clotilde Barrett

Drafting block weaves

The theory of drafting block weaves was discussed in *The Weaver's Journal*, Vol. II, No. 3. Here, we repeat a list of designing techniques which might be helpful:

1. Use the principle of symmetry by sliding a mirror up and down your design and then sideways. Look at the design formed by the original pattern and its mirror image.
2. Balance your design. A major element of balance is proportion: the size of the pattern and its color as it relates to others. Fig. 1 shows the design in which 3 pattern

colors are used in the same proportion, although only two colors are woven at any time. Here also, the proportion of background is large compared to the pattern.

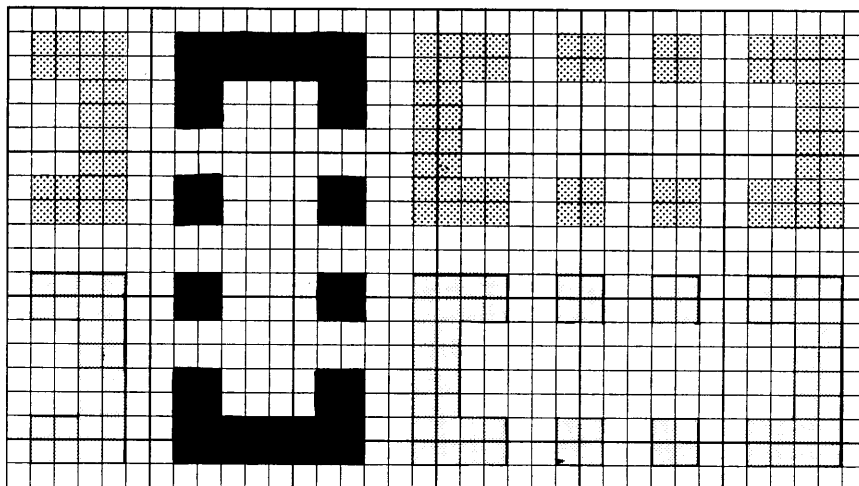

Fig. 1

3. Study the form of the negative as well as the positive areas of the designs. See Fig. 2.

4. Make a negative of your pattern (black becomes white and vice versa) and set it off against the original positive pattern. See Fig. 3.

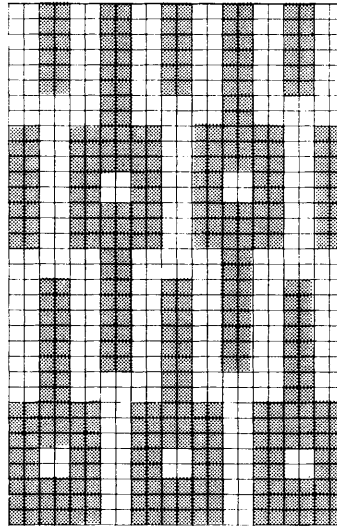

Fig. 2

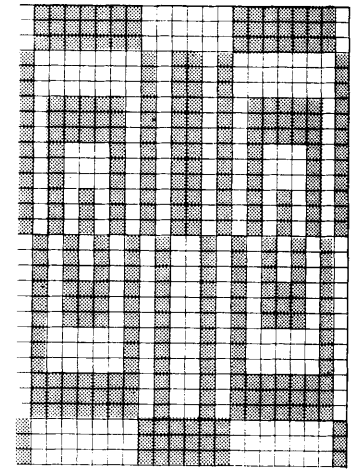

Fig. 3

Study of woven structures

The study of the weaves which adapt best to loom controlled designing is a complex one and will be limited here to a few structures and a study of their advantages and their problems.

Let's compare (A) the four block overshot draft of Fig. 4 which we have woven as bound-weave at 8 epi (30/10 cm) in Plate 3 and (B) the four block Summer and Winter draft of Fig. 5 which we have woven on opposites at 10 epi (40/10 cm) in Plate 4.

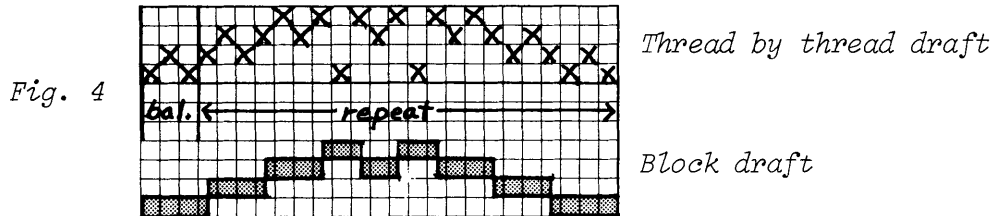

Fig. 4

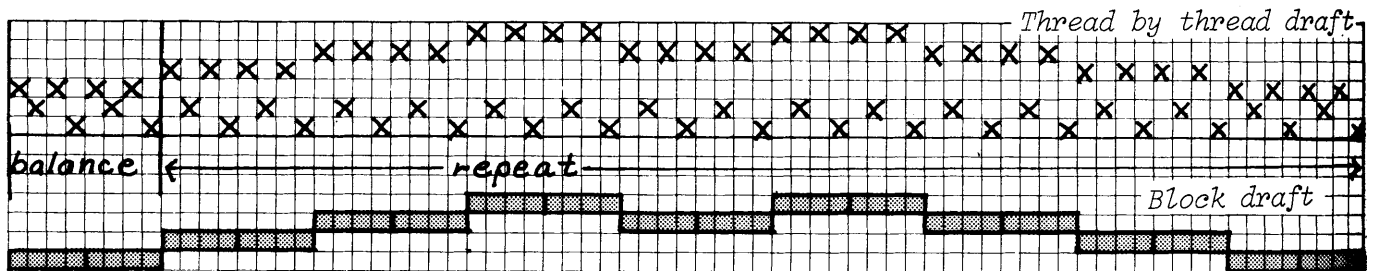

Fig. 5

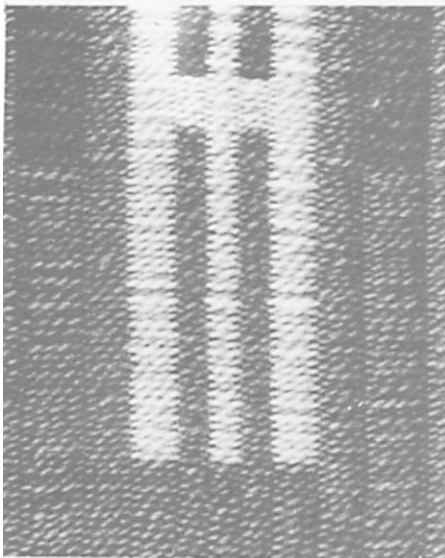

Plate 3 (Detail of Plate 5)
Overshot-Project A

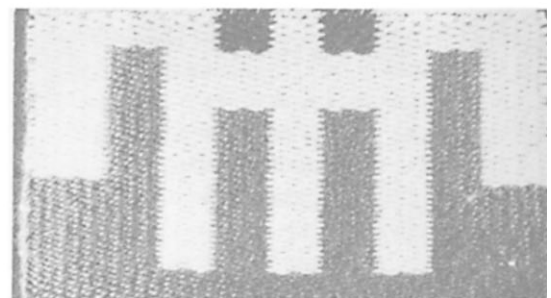

Plate 4 Summer and Winter-Project B

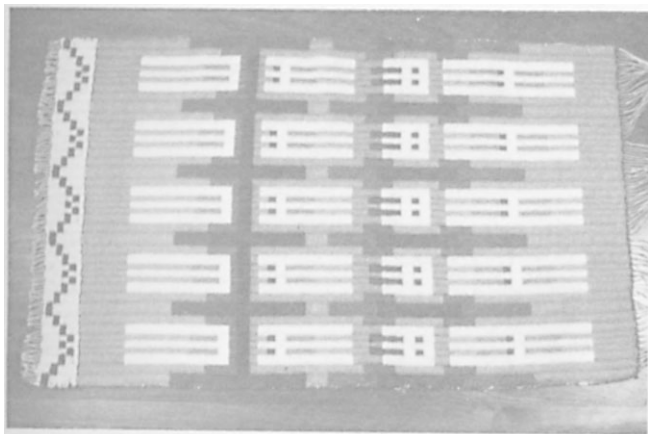

Plate 5
Overshot rug and 'key'

1. The block draft of B is a profile draft in which each unit corresponds to a well-defined number of warp ends (in this case 4) while the relationship between the block draft and the thread-by-thread draft of A is less clearly defined.

A very useful method for deriving the block draft from an overshot threading draft is to weave a 'key' in the heading of a boundweave project. See Plate 5. This key can be unravelled when the piece is taken off the loom and the warp becomes fringe.

To weave the key:

- | | | | | | |
|----|--|-------------|----|--|-------------|
| 1) | treadle 1 weave black
treadle 2 weave white
treadle 3 weave white
treadle 4 weave white | } repeat 4X | 3) | treadle 1 weave white
treadle 2 weave white
treadle 3 weave black
treadle 4 weave white | } repeat 4X |
| 2) | treadle 1 weave white
treadle 2 weave black
treadle 3 weave white
treadle 4 weave white | } repeat 4X | 4) | treadle 1 weave white
treadle 2 weave white
treadle 3 weave white
treadle 4 weave black | } repeat 4X |

Reproduce this key on graph paper and use this block draft for designing patterns for this specific threading.

2. The floats in A are long (the length of the entire block) while the floats in B are over 3 warp ends (occasionally over 2).
3. A requires 4 harnesses for 4 blocks. B requires 6 harnesses.
4. A is well suited for a sequence of 4 color picks. Each pick gives its color to a block. B is best suited for 2 color picks (3 if one weaves Summer and Winter in polychrome).

JACOB ANGSTADT DESIGNS

Jacob Angstadt
His Weavers Pattern Book

Jacob Angstadt Designs
Drawn from
His Weavers Pattern Book

TWO BOOKS REVEAL 18th CENTURY MASTER WEAVER'S RECORDS

A photographic replica of Jacob Angstadt's pattern book; 307 coverlet and tablecloth drafts; 237 tie-ups for point twill drafts on 6, 8, 12, 16, 20, 24, 28 and 32 shafts. Companion book contains nearly 500 drawdowns from the profile drafts and point twill tie-ups. Designs adaptable to unit weaves on 5 to 10 shafts. Prepared by Ruth N. Holroyd with Ulrike L. Beck. 8½ x 11" Hardbound set totaling 400 pages. \$39.95 per set*

Published & Distributed by:
Ruth N. Holroyd
20 Old Farm Circle
Pittsford, N.Y. 14534 U.S.A.

Add \$1.50 Postage & Packaging (\$2.50 Overseas) per set - *N.Y. State residents add 7% tax. - Dealer inquiries invited.

NOW AVAILABLE!

Seminar or Workshop: "Playing with Profiles". Interchanging unit weave systems within multi-harness profiles. Inquire. Ruth N. Holroyd, Instructor



Plate 7

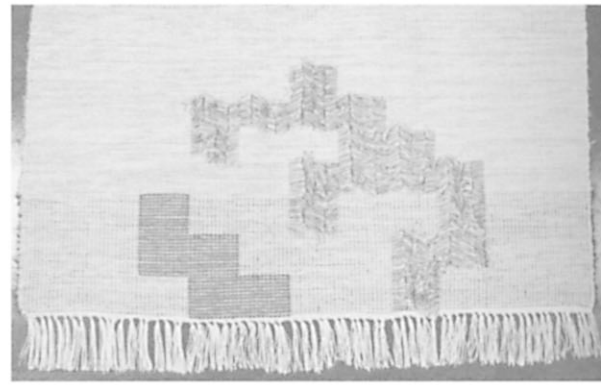

Plate 8

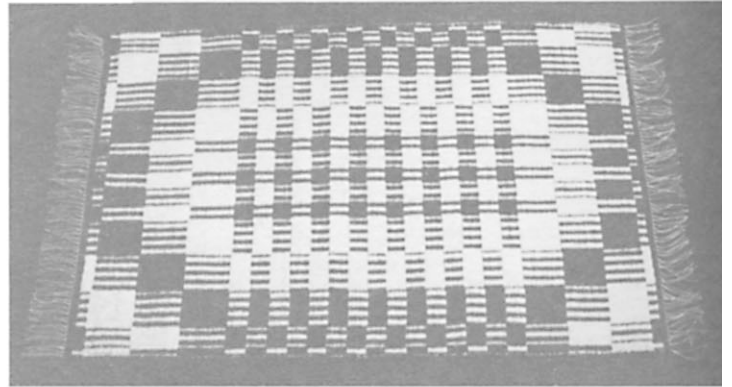

Plate 9 Summer and Winter Rug woven by Ellen Champion

Plate 6

Visual and tactile effects in loom controlled weaves

Certain weaves lend themselves to a large array of visual and tactile effects; Plates 6, 7, 8 and 9 show a few of the many effects one can produce on Summer and Winter threadings.

Plate 6 shows a motif woven on several treadlings using tabby. This design requires 8 harnesses.

Plate 7 shows pile and figure motifs on 4 harness Summer and Winter.

Plate 8 shows multiple harness Summer and Winter in which pile and color blocks are juxtaposed.

Plate 9 is a rug woven on Summer and Winter simulating the visual effects of colonial overshot patterns.

In contacting any of these advertisers, please mention that you saw their ad in "The Weaver's Journal".

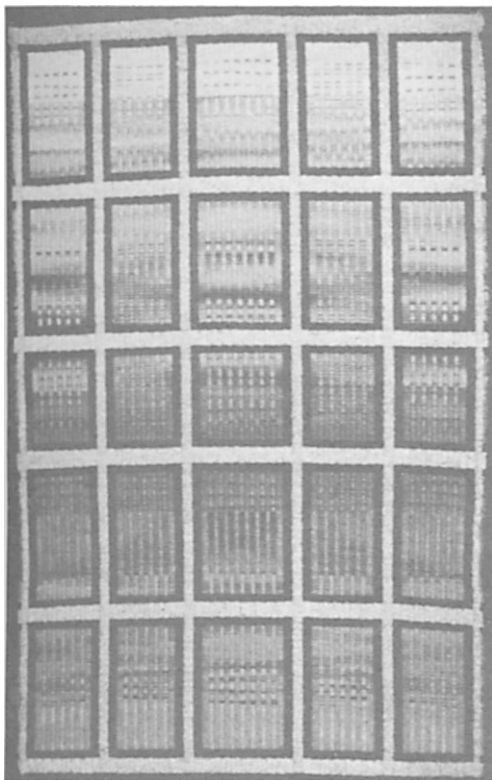

Certain weaves adapt well to special color effects; simple overshots and twills give striking results with pick and pick sequences using two, three or four colors. The rug shown in Plate 10 shows a 4-color sequence in which two of the weft yarns are dyed for variegated color effects to attain subtle variations of tones.

There is a definite relationship between the structure of the weave and the size of the design. In general, the block of the weaves that can be interpreted by a profile draft, such as the two tie-down harness weaves, are unlimited in size while many other blocks are limited by the size of the warp or weft floats.

The weave structures have to be studied in relationship to the function of the cloth.

Plate 10

Rug woven by Charlotte Ziebarth

The knowledge of the weaves is thus an important requirement for the successful expression of ideas through the technique of loom-controlled design. Nevertheless this is not all. Other factors are of major importance. Above all, the *ingenuity of the weave*. The weaver often can overcome certain limitations of the loom by designing quick hand-held half-harnesses consisting of a bar and string heddles, he can devise extra treadles, and he can use pick-up techniques to supplement loom-controlled techniques.

When designing for loom-controlled weaving one must never lose sight of the various elements that come into play when using fiber as an art medium. The materials and colors chosen as data and the pattern for which the loom is programmed need to reflect the design's sensitivity to texture, line, harmony, balance, rhythm, space, light, direction, focus. Let us say again that the planned textile project is not put in the hands of a robot but that the artist remains in control during the weaving process and after the piece is taken off the loom. A textile that is derived from a loom-controlled design never should be labeled 'mechanical' or machine made. Instead, it should be the product of a concept for which the weaver has chosen a special design approach and has had opportunity of personal input during the entire process of creation.

romniwools

Romni Wools and Fibres Limited

3779 West 10th Avenue
Vancouver, B.C., Canada V6R 2G5



Write for our FREE catalogue on our large selection of spinning and weaving equipment.
Sturdy Drum Carder \$95. in kit form.
22" Table Loom \$160. in kit form. Folds flat like a suitcase while warp is on.

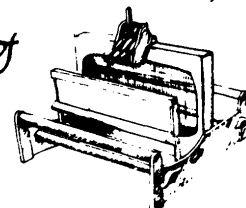

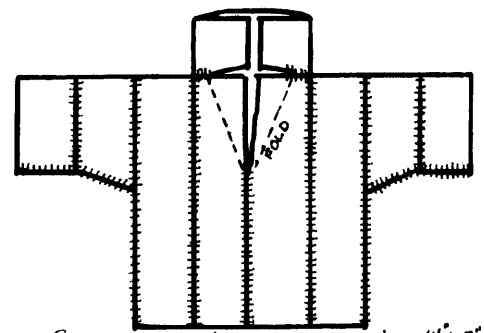
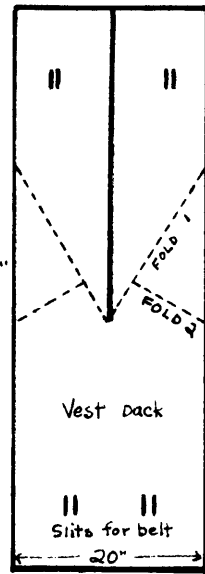
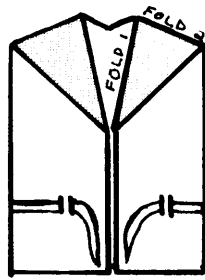
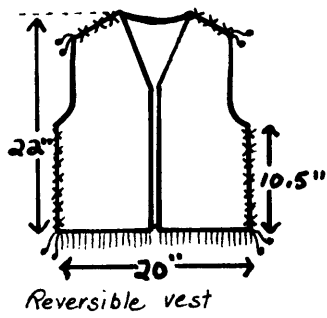

Trace this vest pattern on paper, cut and fold to see how it works.

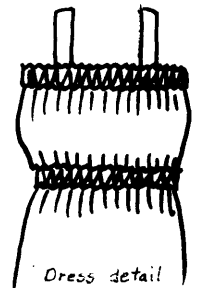
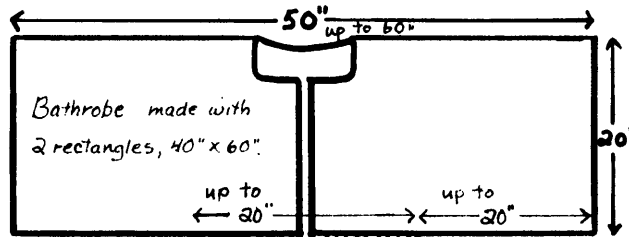
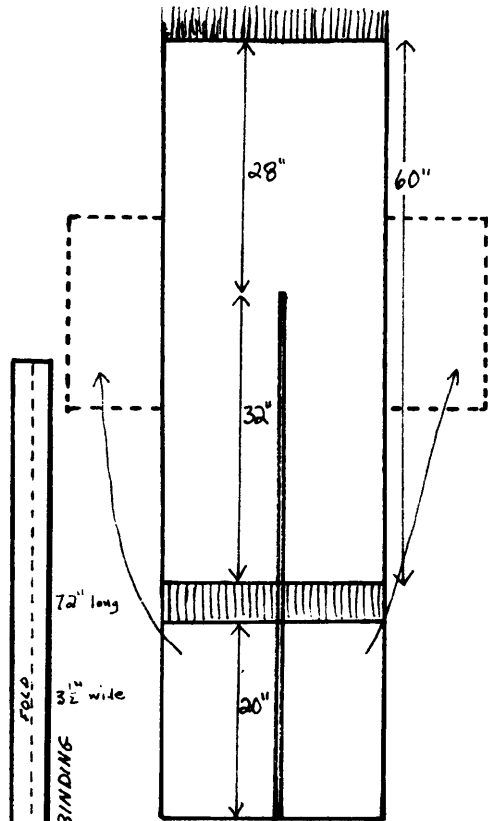

Use with a belt.

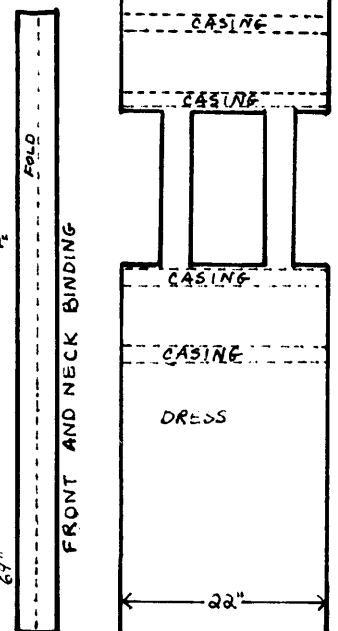
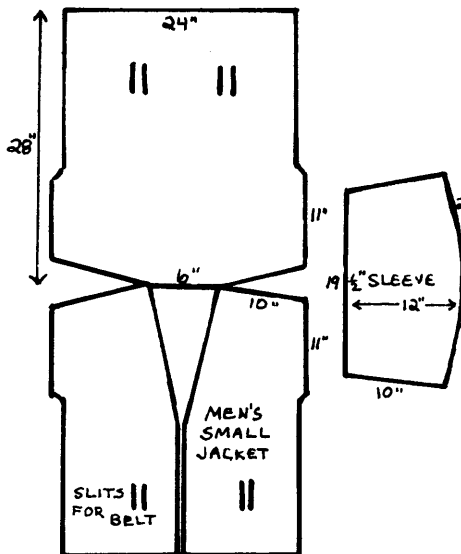
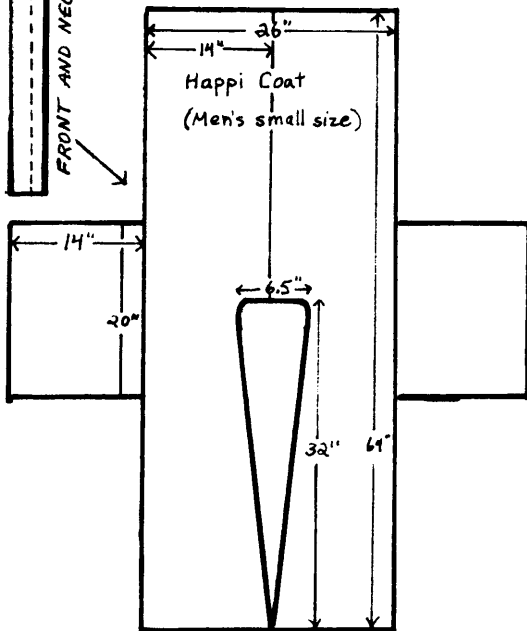

Simple Patterns For Handwoven Garments

Handweavers are always on the lookout for patterns that require very little cutting and that are not wasteful of fabric. A few suggestions are given here in the hope that they will stimulate ideas. It is assumed that weavers will interpret these patterns according to their own needs and that they will produce garments with a very personal character. The measurements which are given are only approximate and often they do not include seam allowances. The patterns should be tried for size by making the garment first out of old sheets or muslin. Handwoven yardage has to be preshrunk by washing the fabric.

Simple patterns require that the fabric have character, that it drape well and that it feel comfortable.

If the yardage seems to be the wrong size, rely on piecing and inserts. The possibilities of interpreting these patterns is limitless.

Other fiber techniques such as coiling, crocheting, knitting, quilting, and embroidery can be used imaginatively to give garments a very individual touch.

Reversible Vest

Sew lining to each of the three pieces, right sides together, keeping fringed edges open. Turn right side out. Hand sew the pieces together at shoulder and side seams, using decorative stitches.



THE WEAVER'S WAY ALTERNATIVES

Verel Handweaving Yarn

NEW - ALTERNATIVE II in 2/2 cotton count - 800 yds./lb.
Ask for Verel at your local weaving shop or send SASE for free sample card

Dealer Inquiries
Invited

WEAVER'S WAY

306 E. Goldsboro Street
Crown Point, Indiana 46307

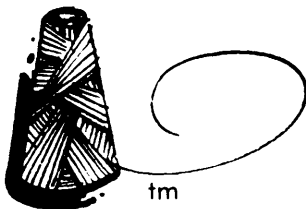

A complete handweaving shop with most models of Leclerc looms on display
Beginning weaving workshops offered quarterly



Plate 1

Sprang and Frame Plaiting For Garments

Sprang and frameplaiting are fixed warp techniques. The warp is tied at both ends and a tensioning device is built in that can be adjusted as the warp takes up.

This fixed warp can be an unwoven section of a loom project. (See Fig. 1) After the project is taken off the loom, the warp is tensioned by placing weights on the woven areas.

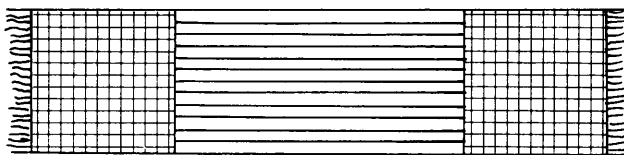

Fig. 1

The fixed warp can also be made by stretching yarn on a frame. (See Fig. 2). One of the warp supports is laced onto the frame. The lacing can be adjusted to tighten the warp.

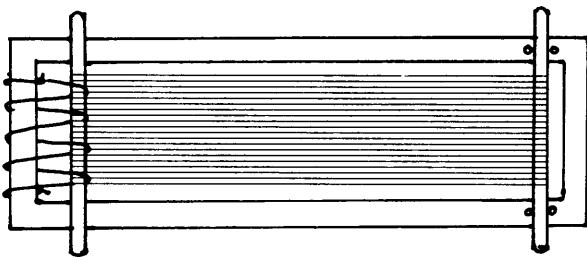

Fig. 2

The warp supports may also be connected to a pair of hooks, using springs or rubber bands as a tensioning device. (See Fig. 3).

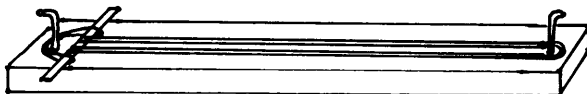

Fig. 3

It is advisable to work with an even number of warp ends. Note that this refers to 'working warp ends' each of these may very well consist of a bundle of 4 or 6 yarns.

Insert a pair of cross sticks (lease sticks) in the warp (see Fig. 4) and start working at the right, just below the lower leasestick, which we will now call the 'holding rod'. The first warp on the right-hand side should lie on top of the holding rod.

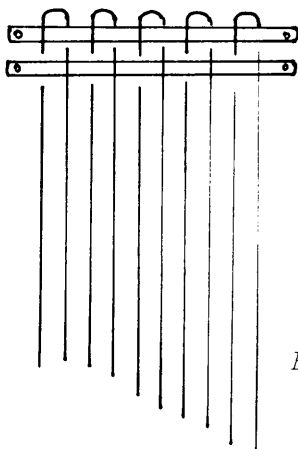

Fig. 4

NOTICE ALL GUILDS: A free get-acquainted examination copy of "The Weaver's Journal" will be mailed to your president upon request.

Free one-year subscription or renewal to your guild in exchange for nine subscription years from your members (new or renewal) mailed in one envelope, accompanied by full payment.

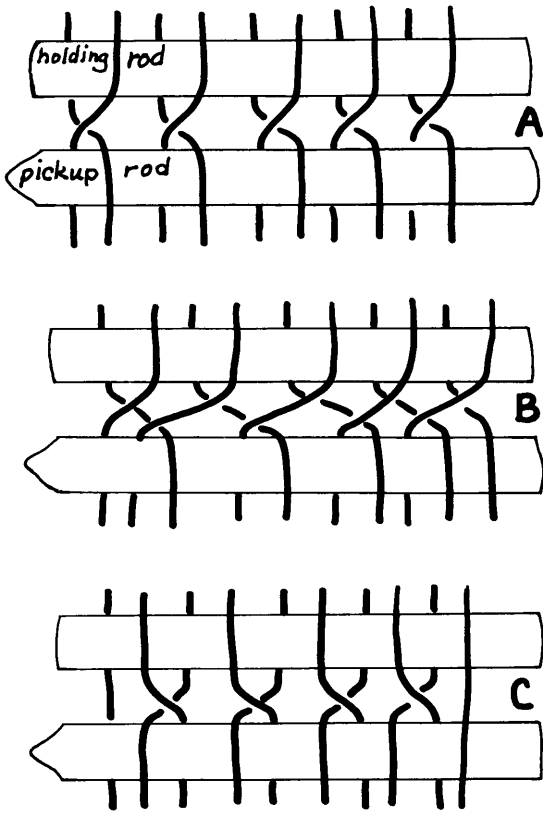

Fig. 5

Fig. 5 A, B and C show the pick-ups used in simple sprang and plaiting.

After such a pick-up is completed, two holding rods are inserted in the picked-up shed. One is pushed to the top of the warp, the other to the bottom.

If a tight interlacement is desired, only the last two holding sticks should remain in the warp on either end. The old ones should be removed and the latest ones pushed hard toward the warp supports. The last pick-up row has to be secured with an additional row of weft thread woven in or with a chaining technique - see Fig. 6.

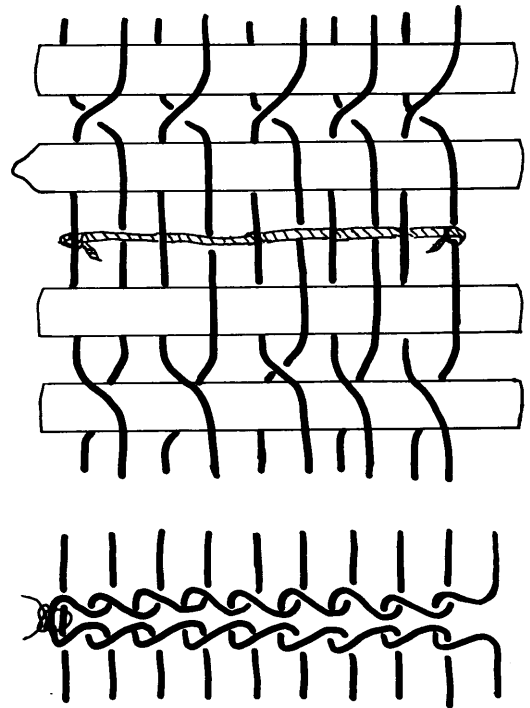

Fig. 6



Plate 2
Sprang shrug made by Ellen Champion
and modeled by her daughter Carol

Sprang Shrug

TECHNIQUE: row B,A,B,A etc.

YARN: heavily textured soft wool, space dyed

LENGTH OF THE WARP: 60" (152 cm)

NUMBER OF WARP ENDS: 100

WIDTH OF THE HOLDING RODS: ½" (12.5 mm)

FINISH: the chaining technique is used to secure the last row of sprang. The wrists are finished by picking up 32 stitches and knitting 4" (10.2 cm) in rib stitch.

The arms are seamed up for 12" (30 cm).



Sprang Disco scarf

TECHNIQUE: row B,A,B,A etc.
 YARN: a lofty elastic 2 ply synthetic-wool blend
 LENGTH OF THE WARP: 60" (152 cm)
 NUMBER OF WARP ENDS: 60
 WIDTH OF THE HOLDING RODS: pencil size
 FINISH: the chaining technique is used to secure the last row of sprang. The ends of the scarf are finished with tassels.

Other suggested uses of sprang

Ski caps, made two at a time, see Fig. 7.

Dress, see Fig. 8.

Disco scarf made by Ellen Champion modeled by daughter Carol

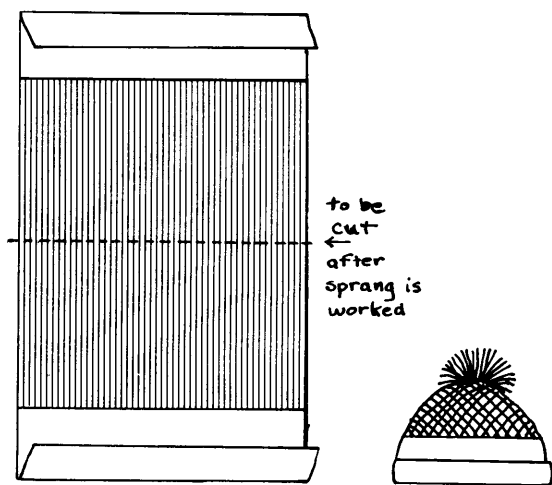

Fig. 7

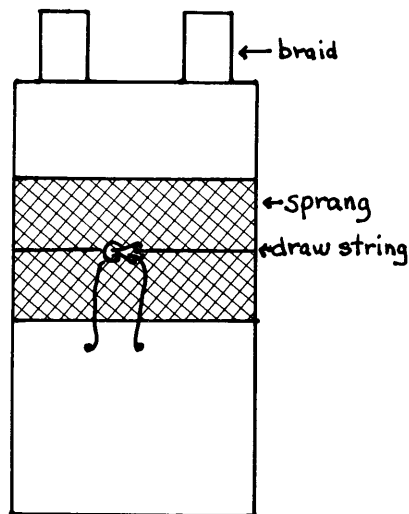

Fig. 8



by Olive and Harry Linder

An authoritative guide for craftsmen interested in learning the secrets of cotton spinning; tools, preparation of fibre, scouring, mordanting, natural dye recipes, shrinkage formulas, uses of handspun thread, plus directions for building your own Charka wheel. 6 x 9, illustrated, paperbound 50 pp. 6.25 post paid. Dealer inquiries welcome.

To: THE COTTON SQUARES
 1347 E. San Miguel Avenue
 Phoenix, Arizona 85014

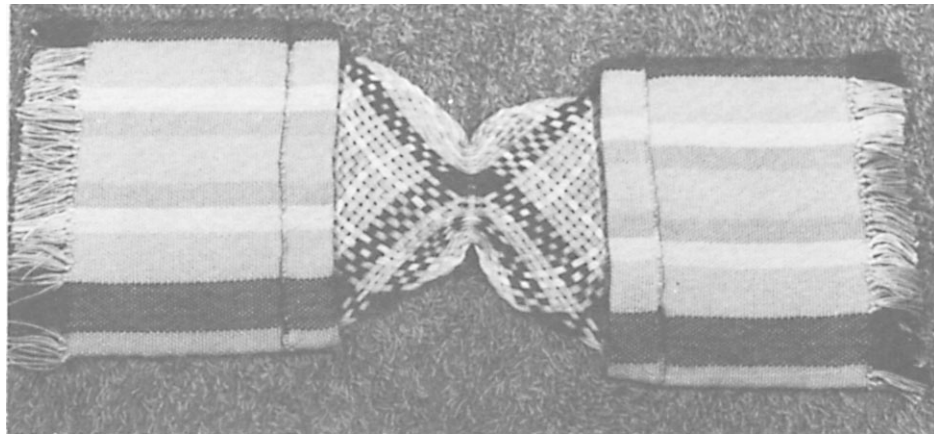

Plate 4

Frame plaited saddle bag

TECHNIQUE: row C,A,C,A etc.

This saddle bag was woven tubular. One layer of the unwoven warp was plaited to make the handle, the other was cut.

Other suggested uses of frame plaiting

A one-piece skirt that fits snugly around the hips and waist; see Fig. 9. Note that it is more practical to weave 2 skirts at a time.

A dress with plaited shoulders. (See Fig. 10).

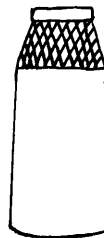
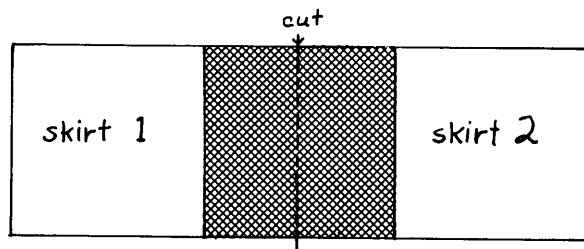
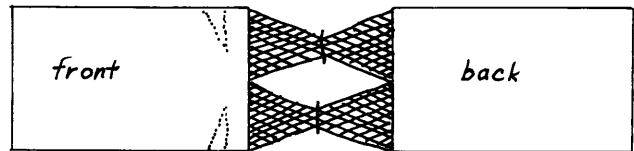
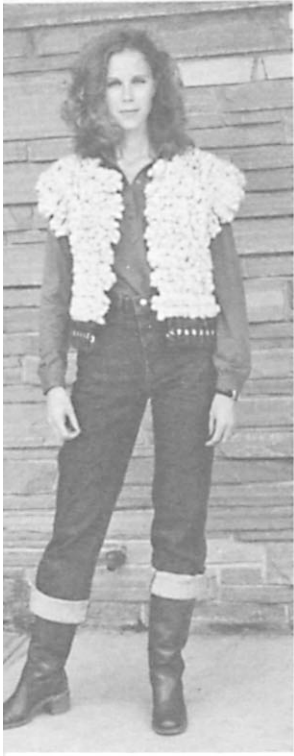

Fig. 9

Fig. 10

Advertise in THE WEAVER'S JOURNAL
 Write for advertising rates
 and details
 The Weaver's Journal
 1900 55th Street
 Boulder, Colorado 80301
 Telephone (303) 449-1170



Garments by Carol Klippenstein

Garments by Barbara Knollenberg



Garments by Emmy Spencer

Garments by Karin Utzinger

The Collection

The Collection was a marketing idea which a group of eight Colorado craftsmen tried recently. They decided to join together for an exclusive one-day sale of their unique one-of-a-kind garments. Together they could present a large and varied collection of garments which would draw more customers than they could attract with individual sales.

Each of the artists works alone in her own studio, and in presenting The Collection, each artist kept her independence and identity. She presented and sold her own garments and talked with the customers.

The group rented a large room at the local Holiday Inn and outfitted it with mirrors and a dressing room. Then each artist selected an area in which she could display and model the garments she had to sell. The group printed a brochure and mailed copies to friends, members of the Handweavers Guild and previous customers.

Customers flocked in all day. They found it exciting to meet the artists and they were captivated by the exclusive, original garments that only craftsmen can provide.

Four of the artists used commercial woven fabrics. They presented original garments featuring tie-dye, batik, leather and quilted techniques. The other four are weavers as well as fashion designers, and therefore, their work is of special interest to handweavers.

Carol Klippenstein featured handwoven scarves, shawls, vests and ponchos in natural fibers and colors. Her garments all reflect a unique quality, from the luxurious yarns she uses to the special care she gives to finishing details.

Barbara Knollenberg specializes in stylish and exclusive garments. In each of her clothing items, she makes a very personal statement combining the aesthetic and the functional.

Emmy Spencer is an exquisite colorist. Her original designs include tunics, vests, coats, skirts, shawls, belts and hats. Her garments are comfortable, easy to wear and harmonize well with handmade or crocheted accessories.

Karin Utzinger weaves fashions for men and women and uses a vast array of fibers and textures. Karin's work is diversified as she experiments with yarns, with styles and with techniques. Karin weaves garments, but her portfolio includes wallhangings and weaving for interiors as well.

The success of the sale was varied. Some of the artists had a more appealing line of garments than others. Some were better salespeople. They did well and made many sales. Those who were less successful, however, often obtained orders for future garments which customers wanted. And all of the artists benefitted from the publicity and interest generated by the sale.



Crackle

Crackle is one of the most versatile four harness weaves. As overshot, it is related to twill and as overshot, it is best explored on four harnesses before trying to extend the theory for more harnesses. As overshot the weave is woven with two wefts, a tabby weft and a pattern weft.

The origin of the weave is a Scandinavian weave called 'jämtlandsvav', named after the province where the weave is an old tradition.

Being a four harness weave, the structure is based on a three harness point twill, of which four types can be threaded on four harnesses. Two repeats of each type are shown in Fig. 1, however there is no limit to the number of repeats.

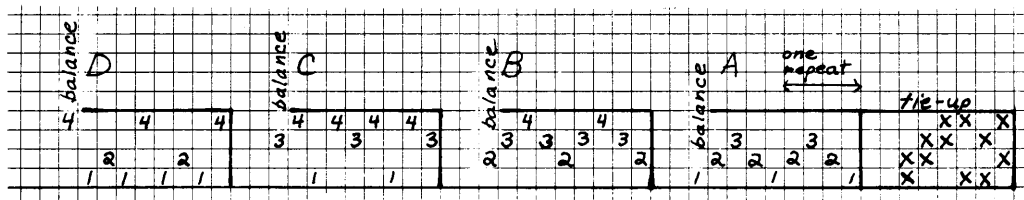

Fig. 1

The tie-up is standard twill tie-up. The twill sheds are woven with a pattern weft. Each pattern weft is followed by one plain weave pick. Each one of the point twill threadings shown in Fig. 1 will correspond to a pattern block of the cloth. Threading A corresponds to block A, threading B to block B, threading C to block C and threading D to block D. Each block consists of one or more repeats of the point twill plus a warp end to balance the block.

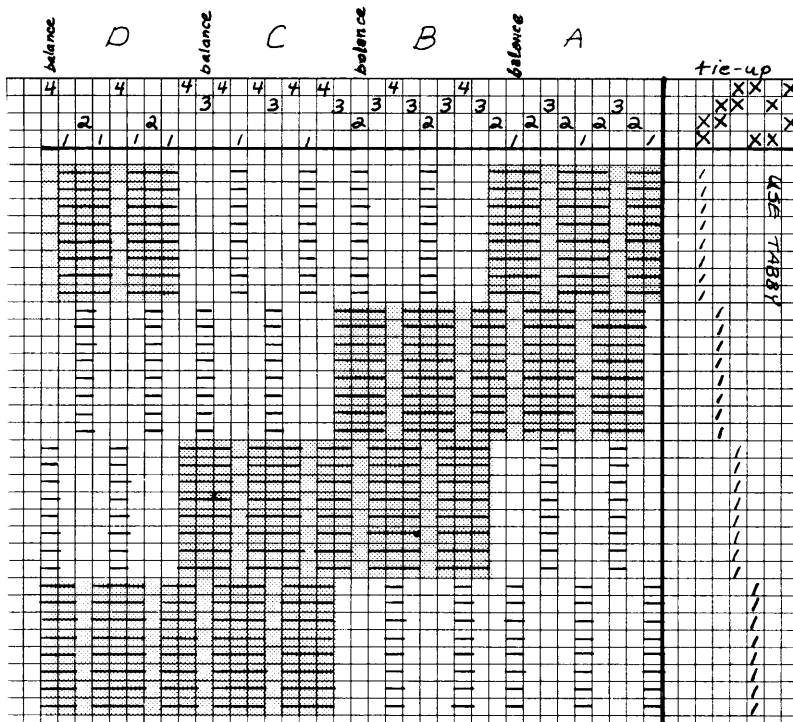

Fig. 2

Pattern blocks distinguish themselves by being areas where the pattern wefts float over 3 warp ends. The transition from one block to another, whether adjacent blocks as in Fig. 2, or opposite blocks as in Fig. 3, needs careful consideration.

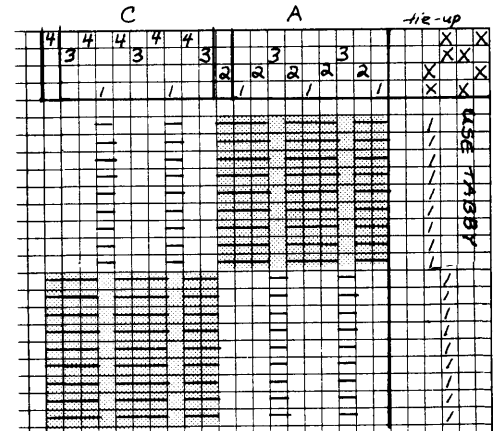

Fig. 3

The odd-even sequence of the harnesses should be maintained to insure that plain weave can be woven and, for the correct structure of the cloth, the pattern float should be over no more than 3 warp ends. The exact threading of the transitional warp end(s) has been the cause of many arguments and debates and has caused the crackle weave to (seemingly) be derived from several threadings. Harriet Tidball's method for threading crackle is the one we recommend for its simplicity and its logic. The rule is: balance the threading within each block. In addition, add a warp end between two opposite blocks to maintain the odd-even sequence.

I hope that the mystery is now taken out of crackle threading so that we can concentrate on the weave structure.

The study of Fig. 2 shows us that 4 harness crackle produces four blocks: A, B, C and D. However the pattern always floats over the plain weave in two of them, and under in the other two.

Sink harness 1 and 2 - pattern appears in blocks A and D
 Sink harness 2 and 3 - pattern appears in blocks B and A
 Sink harness 3 and 4 - pattern appears in blocks C and B
 Sink harness 4 and 1 - pattern appears in blocks D and C

This property can cause unexpected results: Figs. 4 and 5 show an overshoot weave and crackle derived from the same block draft. The patterns are quite different. Remember too that the floats in overshoot are as long as the block; in crackle never longer than over 3 warp ends.

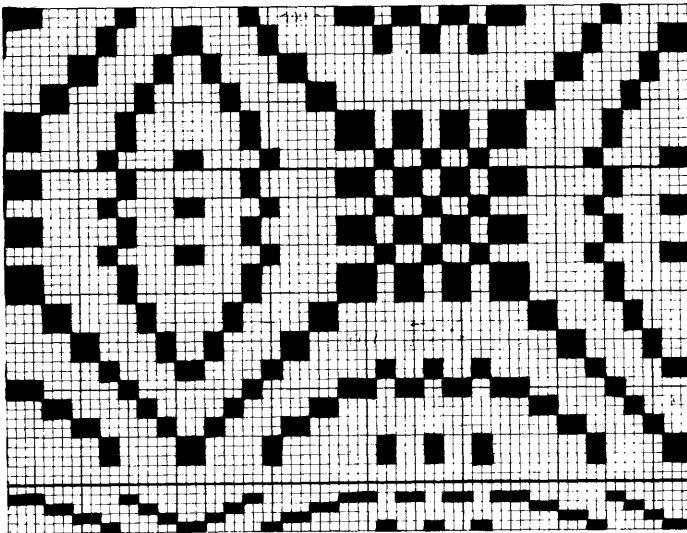

Fig. 4

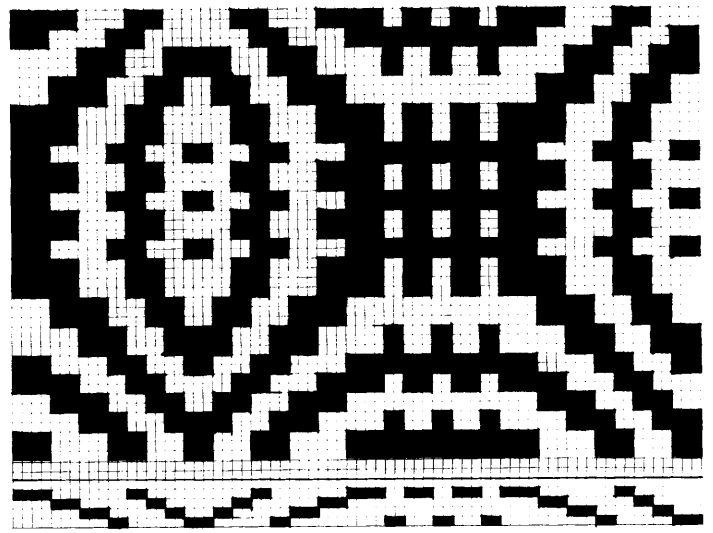

Fig. 5

In contacting any of these advertisers, please mention that you saw their ad in "*The Weaver's Journal*".

Although in general, two adjacent blocks are woven in pattern at the same time, blocks can be designed so that they can be woven alone. For instance, when designing block A it will be woven alone by using the pattern shed H1 + H2 down if there is no D block on either side of block A. It will also weave alone by using the pattern shed H2-H3 down if there is no B block on either side. The same applies to the other blocks. Fig. 6 shows some examples of blocks woven alone.

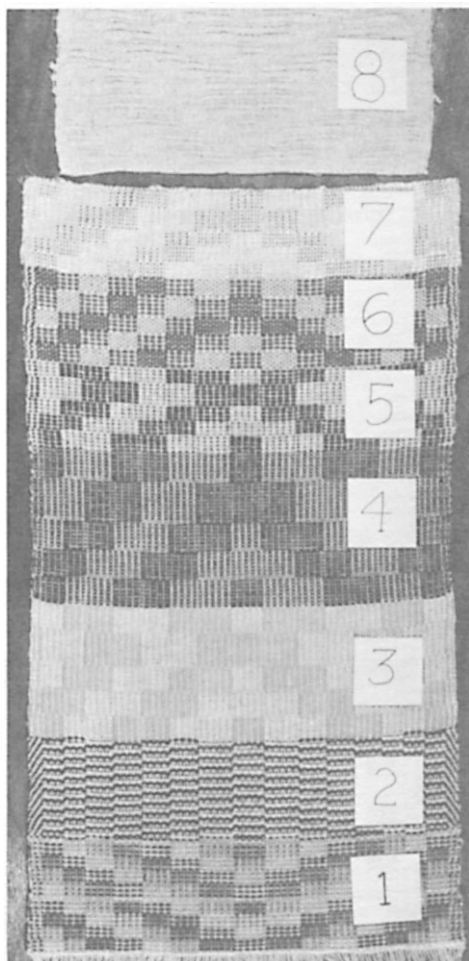

Plate 1
Crackle sampler woven by Maxine Wendler

weaving crackle.

Method 8 is a one weft weave, generally the same yarn as the warp. This weave is not crackle but a textured weave in which a crackle threading is woven in a Bronson Lace manner.

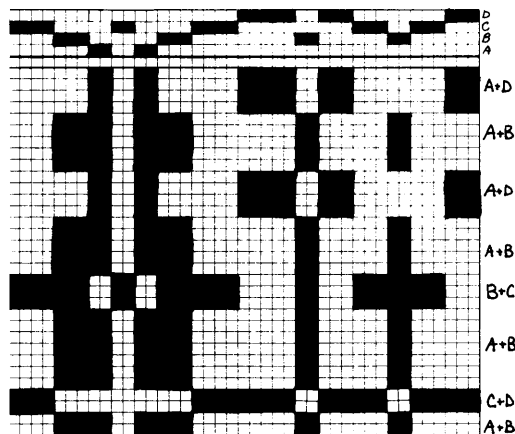

Fig. 6

Methods of weaving crackle

Although, in its classical form, crackle is woven with a tabby weft and a pattern weft, the sample illustrated in Plate 1 shows different methods of weaving crackle. The treading is given in Fig. 7. The warp is cottolin sett at 20 epi (80/10 cm).

TABBY WEFT: same as warp

PATTERN WEFT: several yarns in colors
W, X, Y, Z

Notice that method 1, 2, 4, have no tabby weft. These techniques are basically weft face weaves and should be woven on a warp sett farther apart.

Method 3 shows the classical way of

SELV.	A	B	C	D	C	B	A	SELV.	1	2	3	4	a	b
4		4	4	4	4	4	4	4	4	4	4	4	0	0
3	3	3	3	3	3	3	3	3	3	3	3	3	0	0
2	2	2	2	2	2	2	2	2	2	2	2	2	0	0
1	1	1	1	1	1	1	1	1	1	1	1	1	0	0
1x	3x	3x	3x	4x	3x	3x	3x	1x						

	1	2	3	4	a	b
4			0	0	0	0
3		0	0	0	0	0
2	0	0	0	0	0	0
1	0	0	0	0	0	0

	1	2	3	4	a	b
4			0	0	0	0
3		0	0	0	0	0
2	0	0	0	0	0	0
1	0	0	0	0	0	0

Method 1
Flamepoint
no tabby

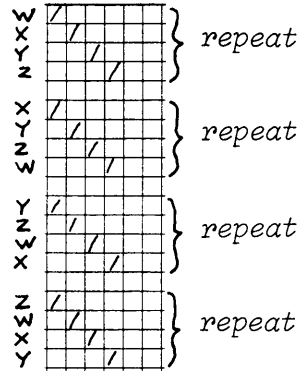

Method 6
Summer
&
Winter

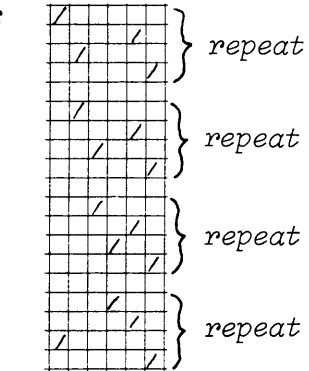

Method 2
On opposites
no tabby

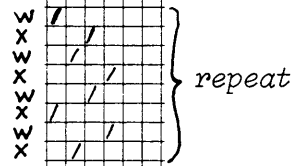

Method 7
Polychrome
2 pat. colors
plus tabby

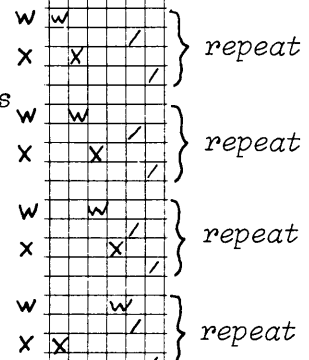

Method 3
As drawn in
plus tabby

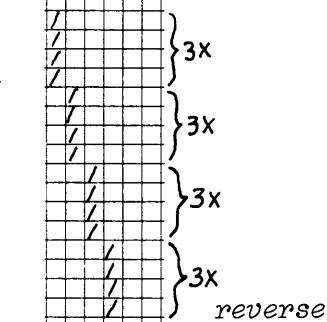

Method 8
Lacey weave
one weft for
pattern and
tabby

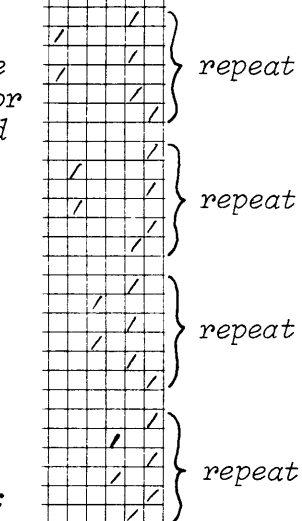

Method 4
As drawn in
on opposites
no tabby

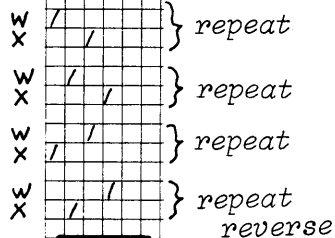

Method 5
Shadowweave
as drawn in
2 tabbies
after each
pat. shot

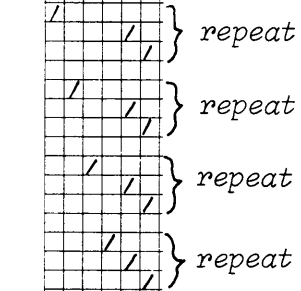

Note:
Do not repeat same tabby
twice from 1 block to another.

Fig. 7

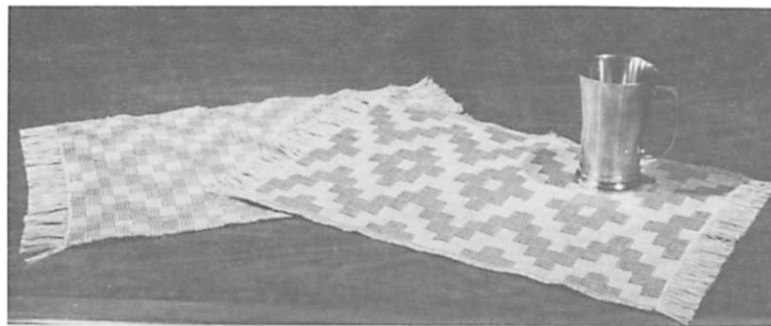

Plate 2
Placemats woven by Maxine Wendler
To the right - woven according to method 3
To the left - woven according to method 6

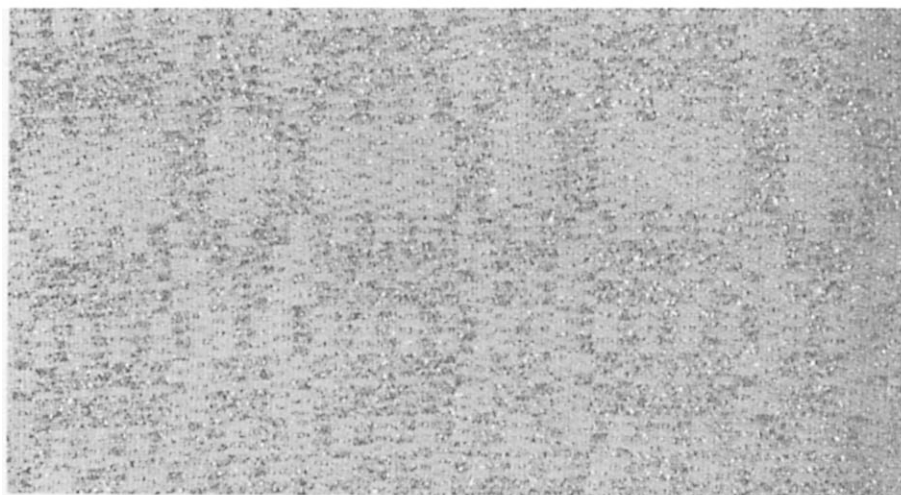

Plate 3
Silk yardage woven by Clotilde Barrett

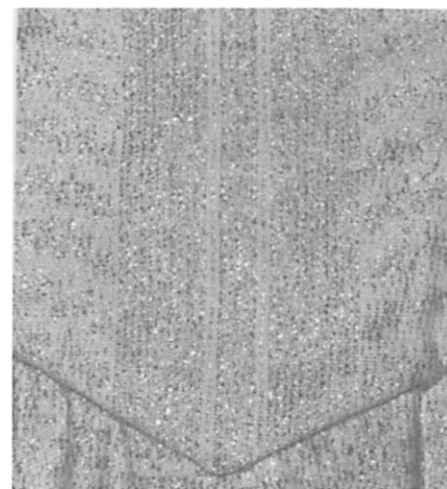

Plate 4
Yoke of a silk and metallic dress woven in crackle weave

Plates 3 and 4 show yardage for and yoke of a cocktail dress. The warp is spun silk sett at 30 epi (120/10 cm). The tabby weft is the same as the warp. The pattern weft is a fine metallic gimpe. The pattern of Plate 3 is woven as drawn in, following method 3. The inset (plate 4) uses a slight variation of the treadling order. The pattern is large, and is derived from a Colonial over-shot motif. One repeat takes 270 warp ends. For dress material, the pattern weft should be related to the background in color and size. Strong contrasts are usually less successful.

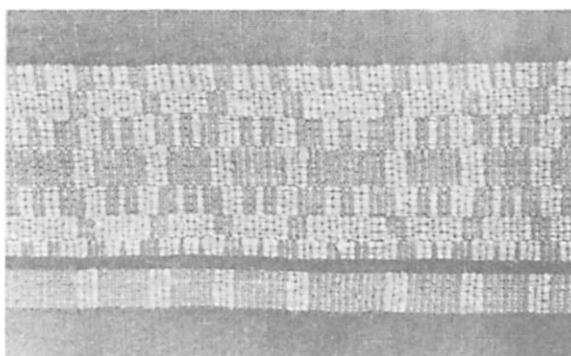

Plate 5 shows silk plain weave yardage decorated with crackle bands. The warp is tussah silk sett at 15 epi (60/10 cm). The tabby weft is the same as the warp. The pattern weft is a silk blend called Buttermilk from Robin & Russ. The threading is given in Fig. 8. The crackle is woven according to method 3, Fig. 7.

Plate 5

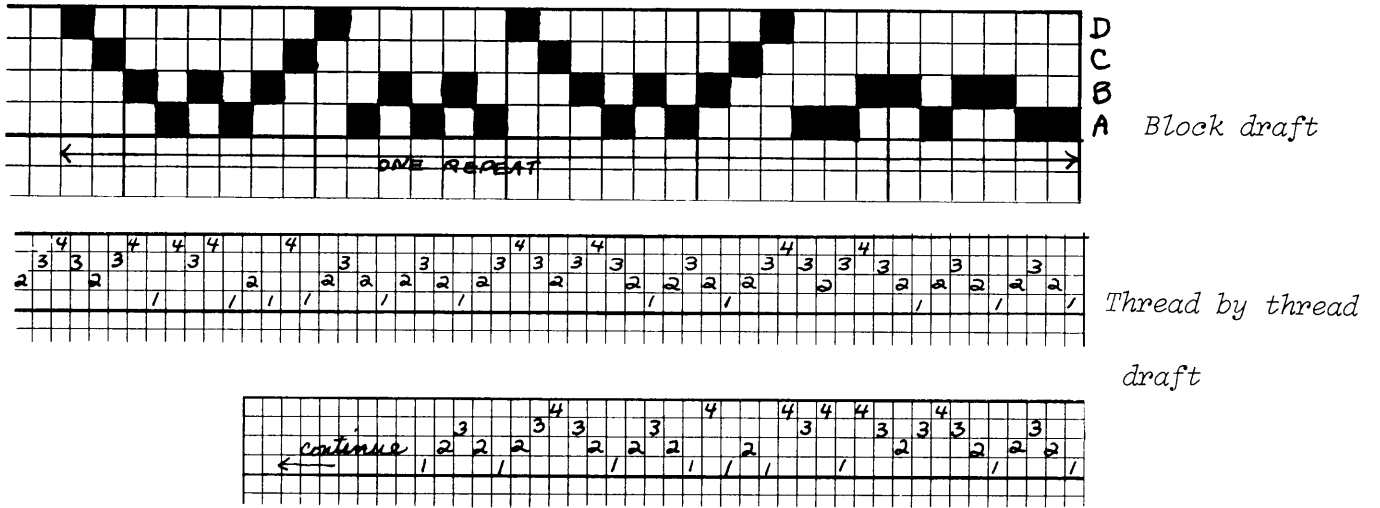

Fig. 8

Monochromatic crackle such as this one is very effective. The blocks of pattern wefts contrast with the background with a pleasing texture.

The firm texture of these weaves makes them suitable for upholstery, mats, pillows and purses.

Four Harness Crackle Rug

It was pointed out that method 1, 2 and 4 (Fig. 7) are more adaptable to weft face weaving and can be used for rugs. So far, we have only explored #4 and the result was not satisfactory. The warp bunches up in groups of three. When these warp ends regroup to be woven into the next block, there is a tendency for the warp to show and the weave to pucker (see Fig. 9). A thin invisible tabby pick following each pair of pattern picks will remedy this problem.

However, let's explore a new way of weaving crackle rug which has tremendous design possibilities and produces a beautiful and functional rug texture. The idea is based on combining method 4 and method 6 in a weft face, no tabby weave. Method 4 is weaving on opposites. Method 6 is a Summer and Winter way of weaving crackle.

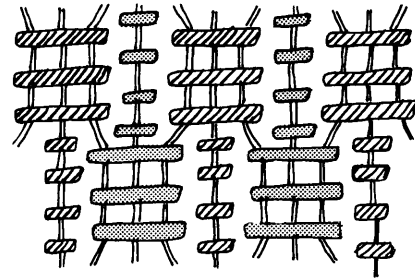
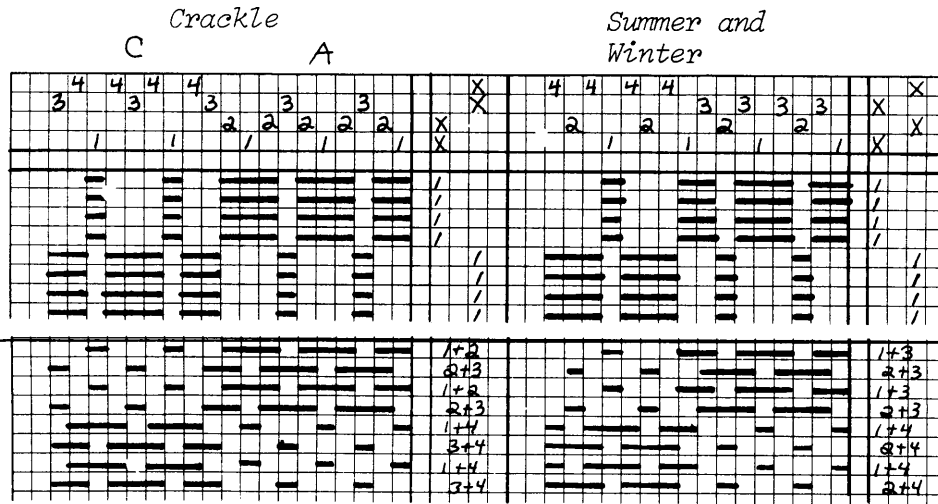

Fig. 9

ORDER ALL YOUR WEAVING, SPINNING, DYEING BOOKS AT DISCOUNT

Any good, standard Classics and many New Titles
Also Needlework, Hobbies, Crafts, Dolls, Miniatures
10% discount on any U.S. books

KATHERINE RAMUS 2100 E. EASTMAN AVE., ENGLEWOOD, CO 80110



How do crackle and Summer and Winter relate? Figs. 10 and 11 show two opposite crackle blocks and two Summer and Winter blocks side by side. In Fig. 10 both threadings are woven with a crackle texture; in Fig. 11 both are woven with a Summer and Winter texture. The cloth structure for both threadings is identical except for the length of the pattern floats which make the transition between blocks. The fact is that every other warp in our crackle threading is on H1 or H3; H1 and H3 are the tie-down harnesses. Every other warp in our Summer and Winter threading is on H1 or H2; H1 and H2 are the tie-down harnesses. One may switch from one weave to the other by interchanging H2 and H3.

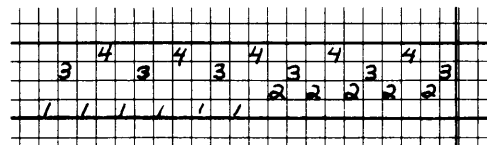
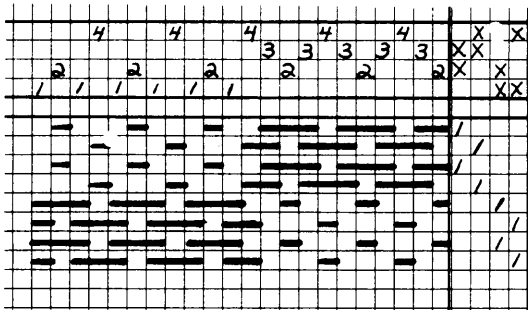
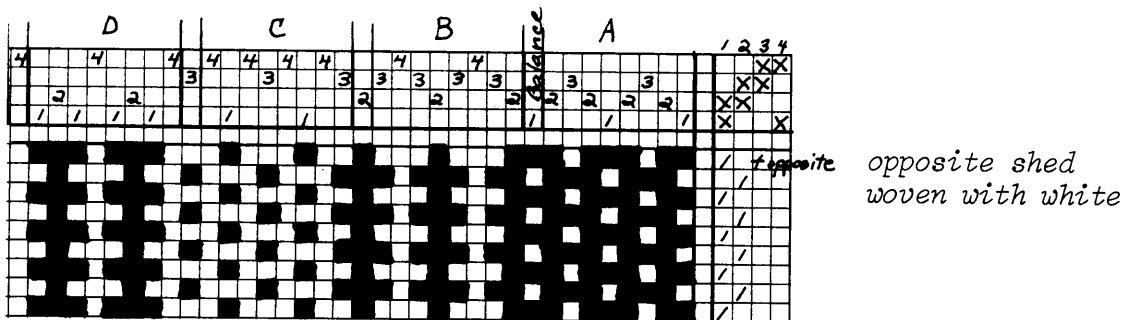

Fig. 12 shows the other two opposite crackle blocks woven as Summer and Winter. Here H2 and H4 are the tie-down harnesses. Let's switch H2 and H3 again and the result is the threading of Fig. 13, which is (except for the transitional warp end) a two-block Summer and Winter threading with H3 and H4 as tie-down harnesses.

It appears thus, that under *certain circumstances* 4 Summer and Winter blocks can be woven on a crackle method threading. This only happens when crackle is woven in the Summer and Winter method and also on opposites (see Fig. 14).



To weave block A in black and block C in white:

- Treadle 1-2 black
- Treadle 3-4 white (this is the opposite)
- Treadle 2-3 black
- Treadle 1-4 white (this is the opposite)

Block B and block D will show up as half tones with a pick and pick effect on the surface.

To weave block B black and block D white:

- Treadle 3-4 black
- Treadle 2-1 white
- Treadle 2-3 black
- Treadle 1-4 white

To weave block D in black and
block B in white:

To weave block C black and block A white:

- Treadle 3-4 black
- Treadle 1-2 white
- Treadle 1-4 black
- Treadle 2-3 white

- Treadle 1-2 black
- Treadle 3-4 white
- Treadle 1-4 black
- Treadle 2-3 white

This ability to weave 4 blocks and to weave black, white and half tone blocks, leads us to look at colonial overshot patterns. The 6 harness Summer and Winter rug discussed in *The Weaver's Journal* Vol. III, No. 1 was similarly inspired by colonial overshot patterns (any overshot pattern may be used). We used the same one as in *The Weaver's Journal* Vol. III, No. 1. One has to make a block draft first, the block draft is then translated into a thread by thread crackle draft. The rug was woven on opposites and with a Summer and Winter texture.

WARP: 8/3 linen

WEFT: 3 ply rug wool from Henry's Attic and Ray's Eclectic

The materials and sett used were the same as for the Summer and Winter rug referred to earlier. A whole new design field is opened up for 4 harness crackle rugs by being able to use the wealth of published overshot patterns.

In a future article we will discuss multiple harness crackle, especially rugs.

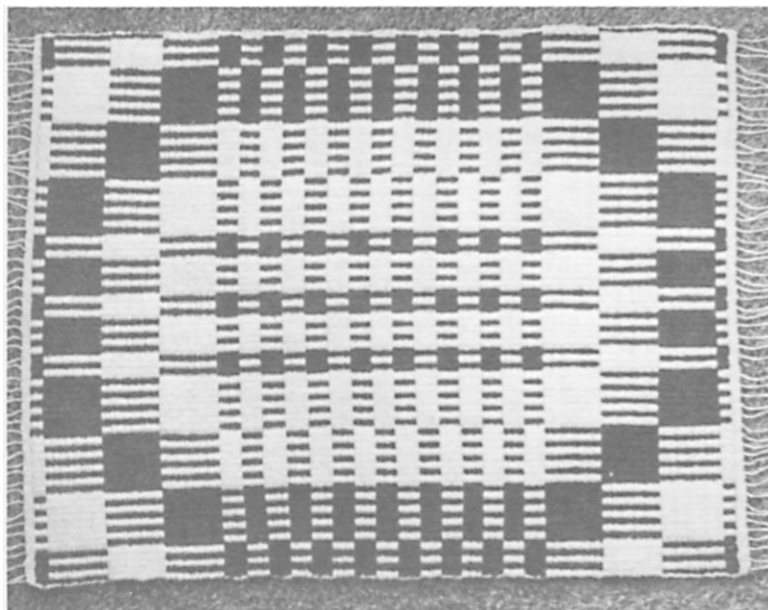
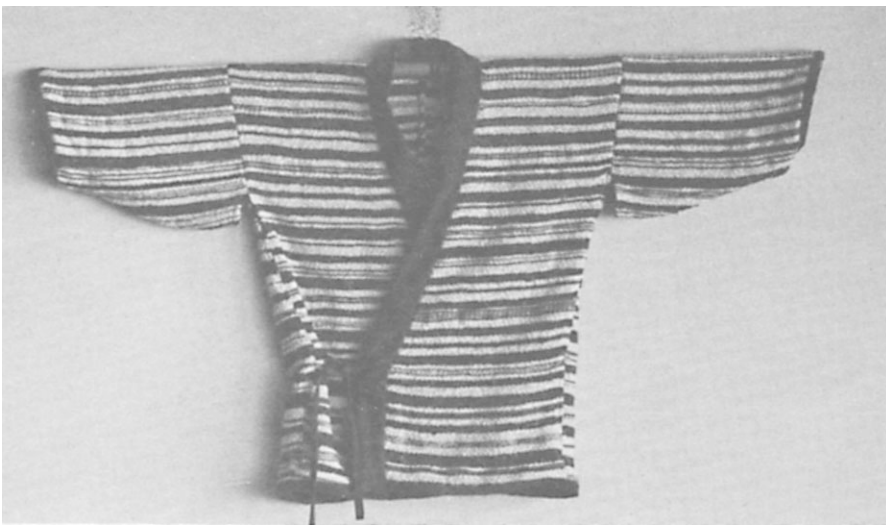

Plate 4
Four Harness Crackle Rug
woven by Jean Anstine





Japanese Shopkeeper's Coat

A small 14 to 15" (36 to 38 cm) wide, two harness loom is all that is needed for this garment which is patterned after a Japanese shopkeeper's coat.

Required fabric:

4 yards (3.66 m) preshrunk woven fabric, 11½" (29 cm) wide.
12" (30.5 cm) ultra suede 45" (114 cm) wide.

Assembly

- Fig. 1 - cut fabric in two 20" (51 cm) lengths and two 52" (132 cm) lengths. Sew backseam, AB and sleeve seams, CD.
- Figs. 2 and 3 - cut away sections E and bind the sleeves with strips of ultra suede cut 1½" (38 mm) wide. See Fig. 3.
- Sew underarm seams, FG.
- Sew side seams, HI.
- Leave underarm CGI open.
- Fig. 4 - turn under the seam allowance, CG, and top-stitch in place. Turn under seam allowance, JC and top-stitch in place. Bind lower edge JJ with a strip of ultra suede 2" (5.1 cm) wide.
- Cut away sections K.
- Fig. 5 - join 2 strips of ultra suede 4¼" (11.5 cm) wide and 32" (81 cm) long. Bind the front and neck opening with ultra suede.
- Attach ties to close the garment.
- Make two 12" ultra suede ties to close the garment. Attach about 6" from bottom edge, to left side seam and to right front seam.

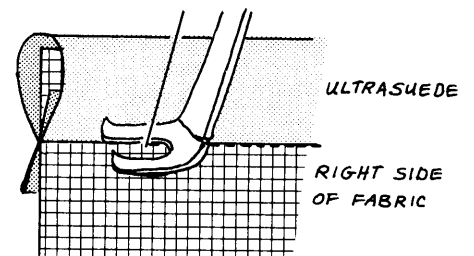
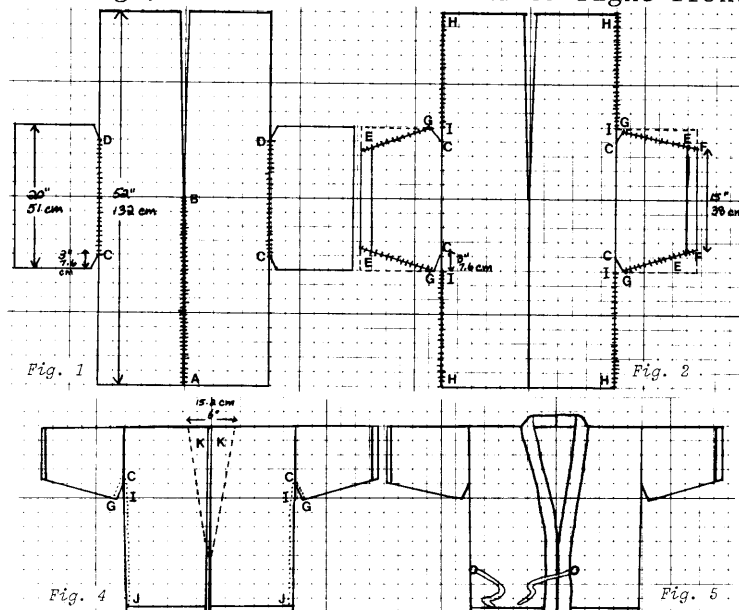

Fig. 3



Book Reviews

MORE THAN FOUR by Mary Elizabeth Laughlin. Laughlin Enterprises Ltd., West Sacramento, CA, 1976, 179 pp.

This book fills a void in the weaving literature; the gap between Mary Black's 'New Key to Weaving' and Gustaf Oelsner's 'A Handbook of Weaves'. The first is a basic text for handweavers, the second is a basic text for the textile industry. The language of these two books seems different, because they are directed to different readers. Yet, with a little effort and a basic understanding of weaving one discovers the key to reading books for the textile industry. They are really readable by the handweaver because the weaving terminology is to a great extent conventionalized. Why then, I wonder, must the author of More Than Four introduce new drafting conventions with a threading draft that weavers cannot even copy on graph paper? (Unconventional weaving drafts unfortunately occur in many self-published books). The language used when referring to weave structures is also obscured because the author feels she has to entertain her readers to keep up their interest.

However, if one puts aside these objections and digs into the content of the book one finds that the author has a great deal to say and to teach. She starts with rib weaves, basket weaves and twills. They are basic weaves, known to the four harness weaver but whose potentials have not been explored. She also selects five weave structures which are those most popular with 4-harness handweavers. In the study of all these weaves, the author emphasizes first the understanding of the interlacement of the cloth and then teaches the process of extending the structure for designing *more than four harness* textiles. The author addresses herself to the handweaver, not to the industry and writes as a teacher, always anticipating potential difficulties.

The other weave structures analyzed in this book are those that 4-harness weavers are not familiar with because they require a minimum of 5 harnesses. There is a section on combination weaves.

A series of appendices deal with sett, fabric analysis, the use of 2 warp beams, and a definition of terms. *Clotilde Barrett*

NAVAJO RUGS - HOW TO FIND, EVALUATE, BUY AND CARE FOR THEM by Don Dedra. Northland Press, Flagstaff, Arizona, 1975, 114 pp. \$7.50

The introductory chapters give background material on Navajo rugs. The author sketches the history of the Navajo tribe and its introduction to weaving. This information and a helpful map of the Navajo reservation should be invaluable to the reader who wants to get acquainted with Navajo rugs.

The chapter on the technical aspects of Navajo weaving, from fiber to weave structure, is neither comprehensive enough to be valuable to the textile connoisseur nor explicit enough to teach the uninitiated. Several styles and style changes of Navajo weaving are described. The chapter on regional rugs is informative; it points out the important role that the traders have played in the evolution of today's Navajo rugs and it gives recognition to outstanding weavers.

The author advises that the best policy for a buyer of rugs of the past is to become knowledgeable. This advice is sound, and therefore one would expect that the information in this book would be more precise and informative with regard to technique and design. This reviewer must object to statements such as, "Twill weaving is sometimes called double weaving as one side mirrors the other in texture and pattern", because of the inaccuracy. Although the book is profusely illustrated with colored and black and white photographs, many of these photographs have been published before and there is never a reference in the text allowing the reader to compare a description of style with an appropriate illustration.

Navajo rugs deserve to be the subject of a more in-depth publication.

Clotilde Barrett

FINISHES IN THE ETHNIC TRADITION by Suzanne Baizerman and Karen Searle. Published by Dos Tejedoras, St. Paul Minn., 1978, 51 pp. Paper, \$5.50.

Fifty-one pages of short, concise, well illustrated directions for finishes are found here, from the overhand knot to Bolivian tubular edging. Planning the finish before and during weaving is stressed. Four parts of the book cover weft protectors, warp protectors, joins, and embellishments, with several examples shown in each section. A good bibliography at the end has helpful hints on what to find in the references listed. 'Finshes' is a handy reference for the weaver's bookshelf.

Ellen Champion

LOOM CONSTRUCTION by Jeri Hjert and Paul Von Rosenstiel. Van Nostrand Reinhold Company, 1978, 160 pp. Paper \$7.95, Cloth \$11.95.

"Loom Construction" offers complete plans and instructions for building 5 popular looms: inkle, tapestry, 2 four-harness table looms and a four-harness jack-type floor loom. Plans and instructions are also included for making inkle, stick, and boat shuttles; a tapestry comb; lease sticks; a tube stand; a warping board; and a weaver's bench. Each project has materials and tool lists, instructions, drawings and photographs. Basic instructions for warping and weaving on each loom accompany the construction sections.

For the novice or experienced wood worker, this book can be a valuable reference, presenting progressive challenges from simple to complex projects.

Both authors are architects, one also a weaver, the other a woodworking enthusiast; so the book is written with clear concise directions easy for the craftsperson to understand.

It offers the added enticement of saving money on weaving equipment, and then starts you off into the world of weaving....

Ellen Champion

THE INVESTIGATIVE METHOD OF NATURAL DYEING by Frederick H. Gerber. Gerber Publications, Ormond Beach, Florida, 1978, 74 pp. \$4.75.

This book is a series of reprints from Handweaver and Craftsman, Brooklyn Botanic Garden Record and Shuttle, Spindle and Dyepot. The articles aim at broadening the scope of the natural dyer. The author encourages the dyer to investigate more plants, more ways of extracting dyes. He encourages him to change many variables in the dye process in order to obtain a wider range of color per plant than that which is recognized in the dye literature. The author himself has investigated the literature, has experimented and has researched techniques. In these articles he shares all of this with his readers with emphasis on the following natural dye plants: indigo, lichens, milkweed, baldunea, prickly pear, pokeberry, cochineal, dye plants of the deep south, and quercitron.

The book is illustrated with drawings and photographs.

Clotilde Barrett

PROFESSIONAL HANDWEAVING ON THE FLY-SHUTTLE LOOM by Laya Brostoff. Van Nostrand Reinhold Co., New York, NY, 1978, 116 pp. \$16.50

What does a reader expect from a book with this title? Laya Brostoff, having a vast experience as a production handweaver, would argue the pros of a fly-shuttle loom. That she does. She stresses the advantages which are mostly time saving; she explains the function of the major parts of the loom, shows how to prepare the warp and gives some practical hints on how to approach the problems of designing for successful production of woven goods.

The chapters on color and on the classification of weaves by structures suffer from the fact that the author and the publisher did not get their act together. The drafts and illustrations do not always relate to the text; drafts are badly laid out, and, although there are color illustrations in the book, color is not used where the text calls for it.

The reader might also expect to find in this book some answers to problems that professional weavers always have to face: how to buy raw materials, how to keep records, how to deal with employees, how to market, how to make contracts, how to keep books, how to organize a production studio, how to design for production. Unfortunately many of these problems are not dealt with at all; others are glossed over too quickly.

At least, this book should be of great help to those who wonder what advantages there would be for their type of work if they would invest in a fly-shuttle loom.

Clotilde Barrett

WOVEN WORKS by John and Susan Hamamura. Chronicle Books, San Francisco, CA, 1978, 95 pp. \$14.95

This book has the appearance of a beautiful catalogue of a fiber show. It is unfortunate, however, that none of the pieces are dated. All the photographs are in color and they are of exceptional quality. Many interesting textural effects are shown with close-ups.

The book is about the roots of some modern woven works that can be traced to designs and techniques of the past. Works of 36 contemporary fiber artists are shown; they are arranged in groups where they are juxtaposed to works of ethnic origin. Each group is headed by a short text explaining their relationship.

In this reviewer's opinion not much is gained by the fact that the authors are trying to match up contemporary works with ancient or ethnic ones. The effort is at best very superficial. I would have preferred comments by the artists themselves about the origins of their work.

Nevertheless, the authors present an exciting collection of works that have been woven today or in the past.

Clotilde Barrett

JAPANESE COUNTRY WEAVING by Mary Lou Maxson. Juniper House, Boulder, Colorado 80301, 1978, 10 pp. \$1.50

Country weaving in Japan is done mostly with cotton. The weave structure is simple but the cloth is embellished with several dyeing, painting, printing and embroidery techniques. The author gives a brief account on how these techniques are used in Japan and on their geographical distribution.

This is a vast subject to tackle in a text that contains about 1600 words. It leaves the reader somehow hoping that more material will be published on this great cultural asset of Japan.

Clotilde Barrett

SOFT AND SIMPLE WEAVING, EASY TO WEAVE WALL DECORATIONS, WEAVING ON DRIFTWOOD LOOMS - Craft Course Publishers, El Monte, California.

These three books ranging from 15 to 23 pages each are part of a series of magazine-like publications, called "Handicraft for Fun" Library.

They will appeal to the hobbyist and to teenagers. All the projects are made on easy-to-build frame looms. The techniques are simple and well explained with line drawings. The designs can be reproduced accurately by following the plans. The appeal of these projects lies in their color and texture. These assets are well brought out through beautiful colored photographs.

These well-prepared booklets surely will give the hobbyist a feeling for working with fiber. Let's hope that once a person gets started on one of the projects described in these books, he will be inspired to create his own designs.

Clotilde Barrett

CONTEMPORARY BASKETRY by Sharon Robinson. Davis Publication, Inc., Worcester, Mass., 1978, 120 pp. \$13.95

With its 291 black and white and 45 color illustrations this book is primarily a collection of basket photos. The author documents the works shown and also explains the basic basketry techniques and materials which are used by contemporary artists. These include coiling, with a separate chapter on using pine needles as a core, twining, and plaiting. Sharon Robinson writes "Take any liberties with the basic techniques and achieve the results you desire," and thus stresses personal expression throughout the book. Materials, the structure of baskets, and the techniques of embellishments are dealt with from a creative viewpoint. This should stimulate experimentation and new approaches to the art of basket making.

Clotilde Barrett

THE INVESTIGATIVE METHOD OF NATURAL DYEING by Frederick H. Gerber. Gerber Publications, Ormond Beach, Florida 1978, 74 pp. \$4.75

This book is a series of reprints from Handweaver and Craftsman, Brooklyn Botanic Garden Record and Shuttle, Spindle and Dye-pot. The articles aim at broadening the scope of the natural dyer. The author encourages the dyer to investigate more plants, more ways of extracting dyes. He encourages him to change many variables in the dye process in order to obtain a wider range of color per plant than that which is recognized in the dye literature. The author himself has investigated the literature, has experimented and has researched techniques. In these articles he shares all of this with his readers with emphasis on the following natural dye plants: indigo, lichens, milkweed, baldunea, prickly pear, pokeberry, cochineal, dye plants of the deep south, and quercitron.

The book is illustrated with drawings and photographs.

Clotilde Barrett



Poncho

by Doris Hurt



Plate 1
Doris Hurt models
her worsted woven
poncho

This bright poncho in yellow and red worsted wool was the first thing I wove on my eight harness loom. Without color, the cloth would have a uniformly mottled appearance characteristic of crepe weaves. The 4-orange, 4-red sequence in both the warp and the weft results in a vibrant checker effect.

WARP: O - 2 ply wool worsted 2/20

R - 2 ply wool worsted 2/17

WEFT: same as warp

SETT: double sley in 12 dent (50/10 cm) reed (24 epi, 100/10 cm)

WIDTH IN THE REED: 36" (86.4 cm)

THE WEAVE*

The draft is given in Fig. 1.

Construction of the poncho

Pattern shown in Fig. 2.

← repeat →	8	tie-up												
		1	2	3	4	5	6	7	8					
O														
	O													
		R												
			R											
				R										
					R									
						R								
							R							
								R						
									R					
										R				
											R			
												R		
													O	
														O

Fig. 1

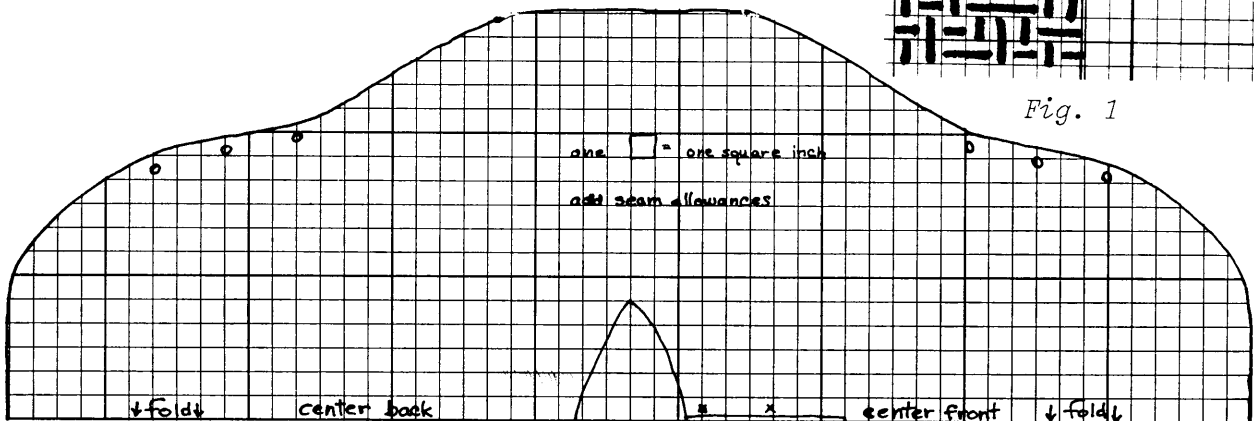

Fig. 2

Cut the lining and the poncho from the same pattern but do not cut out the neck opening. With right sides together, sew alongside the neck and the front opening. Cut the neck opening out, clip curves and reverse the garment.

With wrong sides together, stitch along outer edge of garment. Clip seam

*Reference: Kirby, Mary *Designing On The Loom*, Select Books, CA, pp. 54-55.

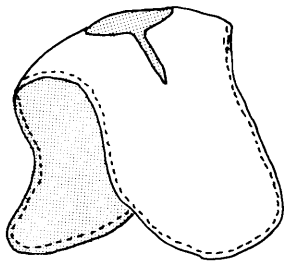

Fig. 3

allowance to $\frac{1}{4}$ " (6.5 mm). Pin fringe to the edge and stitch. Seam binding or tape may be used to finish raw edges. See Fig. 3.

To close the side of the poncho, use buttons and button-holes at the small dots of the pattern.



Finishing the garment with handmade frogs and fringes.

Frogs (see Fig. 4): Pin $\frac{1}{4}$ " (6.5 mm) cord to a sheet of paper in the desired design. Keep any seams on top as this will become the underside when the frog is finished.

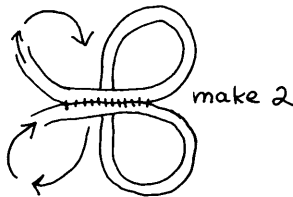

Fig. 4

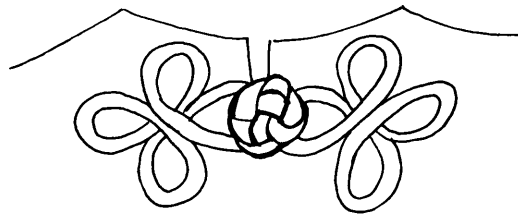

Fig. 5

Plate 2
The closings at the neck and sides makes this poncho a comfortable garment

Make a left and a right half. Secure each loop with small stitches.

Remove from paper. Stitch a button to the left half of the frog. See Fig. 5.

Button (see Fig. 6): Take 8 to 10" (20 to 25 cm) of $\frac{1}{4}$ " cord. Pin end of cord to a sheet of paper. Keep any seams on top and make a first loop. Loop again, over and under the first loop. Loop a third time, weaving through the other two loops. Ease together. Pull knot to close, shape into a ball and adjust the loops to even them up. Trim the ends and sew them flat to the underside of the ball.



Fig. 6

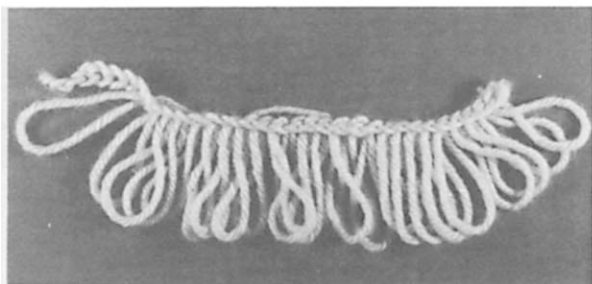

Plate 3
Detail of crocheted fringe

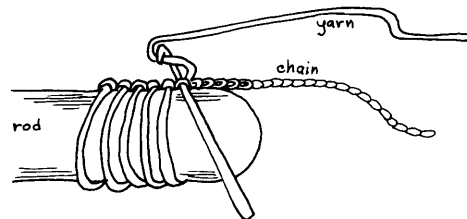

Fig. 7

Crocheted fringe (see Fig. 7 and Plate 3): With a four ply knitting worsted in a color to match the poncho, crochet a chain as long as needed for the fringe plus 1 yard (91.5 cm).

Put the last loop over a broom handle or wooden stick. Pull one loop through each stitch of the chain and slip each loop onto the stick.

When finished, slip the loops off the stick and stitch over the chain by a sewing machine or stitch the chain immediately to the garment, being careful not to pull the loops. The fringes may be cut after they have been stitched.



The Weaver's Market

PLAYING WITH BLOCKS: AN EXPLORATION OF MULTIHARNESS OVERSHOT by Erica Voolich. Four threading systems explained and illustrated; numerous tie-ups and drawdowns; and a step by step method for figuring out tie-ups. Order from Erica Voolich, 244 Summer, Somerville, Mass. 02143. \$3.95 (Mass. residents add .20 tax).

WEAVERS - SPINNERS - KNITTERS - Attend New Zealand NATIONAL WOOLCRAFTS FESTIVAL PLUS 2 weeks sightseeing and visiting woolcrafters. May 10 - 31, 1979. Write: Virginia Norris - Eleanor Voz, 10502 W. Pico Blvd., Los Angeles, CA 90064 (213) 836-3241.

WOODLAND INDIAN FINGERWEAVING TECHNIQUES in on-going series. "Strands & Hands" \$4 each design with authentic methods; \$5.75 includes two colors of material. Crowe & Coulter, WJ, Cherokee, NC 28719.

INNOVATIONS IN FIBER '79 - A National All Fiber Show sponsored by Skyloom Fibres of Denver, Colorado. Open to all U.S. fiber artists working in any media. Juried, commission and cash awards (Apr. 9-30). For information and entry forms write to Skyloom Fibres, 1905 So. Pearl, Denver, Colorado 80210.

USED MILL REEDS cut to any length. Dent sizes 10 3/4, 11 1/4, 14 1/8, 15. Cost 25¢ per inch plus postage and \$1.00 handling. Also Maine mill ends. Send SASE for samples. The Goose Eyed Shuttle, P.O. Box 248, Orono, ME 04473.

WOOL CARDING, recarding of wools for quilt batting, weaving or spinning. Your own wool returned in batting. Send wool from fleece or comforters today, or write for more information, St. PETER WOOLEN MILL, 101-AB West Broadway, St. Peter, MN 56082. Send \$1.00 (refundable) for complete catalog of wool, yarns, and needlework accessories.

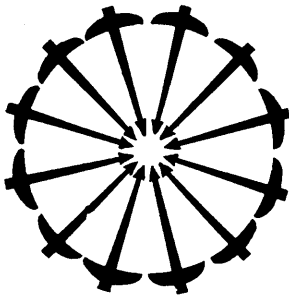

1979 Classes

At the office of

THE WEAVER'S JOURNAL

WINTER CLASSES (start week of Jan. 8)

Beginning Loom Weaving
Double Weave
Weaving for Teachers/Group Leaders

More Than 4H
Rugmaking

SPRING WORKSHOPS

Designing Handweaving for Clothing (March 5-9)
Handling Handwoven Fabric for Clothing (March 19-23)

SPRING CLASSES (start week of April 3)

Beginning Loom Weaving
Basketry
Handspinning
4H and Fabric Analysis
Creative Tapestry

SUMMER WORKSHOPS

Basketry
Spinning
Loom Controlled Design

For Brochure, write to

THE WEAVER'S JOURNAL
1900 55th Street
Boulder, Colorado 80301

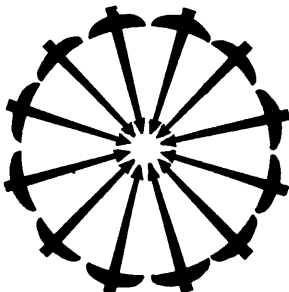

The Weaver's Journal

1900 55th Street
Boulder, Colorado USA 80301
(303) 449-1170

Available back issues:
Vol. I, No. 1, 2, 3; Vol. II, No. 2, 3 @ \$2 each. Vol. II, No. 4; Vol. III, No. 1, 2, 3, @ \$2.50 each plus 25¢ postage per copy. (CO residents add 3½% sales tax). Allow 6 weeks delivery.

U.S. POSTAL SERVICE STATEMENT OF OWNERSHIP, MANAGEMENT AND CIRCULATION (Required by 39 U.S.C. 3685)		
1. TITLE OF PUBLICATION THE WEAVER'S JOURNAL		2. DATE OF FILING 8-25-78
3. FREQUENCY OF ISSUE quarterly	A. NO. OF ISSUES PUBLISHED ANNUALLY 4	B. ANNUAL SUBSCRIPTION PRICE \$9.00
4. LOCATION OF KNOWN OFFICE OF PUBLICATION (Street, City, County, State and ZIP Code) (Not printers) 1900 55th St., Boulder, CO 80301		
5. LOCATION OF THE HEADQUARTERS OR GENERAL BUSINESS OFFICES OF THE PUBLISHERS (Not printers) 1900 55th St., Boulder, CO 80301		
6. NAMES AND COMPLETE ADDRESSES OF PUBLISHER, EDITOR, AND MANAGING EDITOR		
PUBLISHER (Name and Address) Clotilde Barrett, 1900 55th St., Boulder, CO 80301		
EDITOR (Name and Address) Clotilde Barrett, 1900 55th St., Boulder, CO 80301		
MANAGING EDITOR (Name and Address) Clotilde Barrett same address		
7. OWNER (If owned by a corporation, its name and address must be stated and also immediately thereunder the names and addresses of stockholders owning or holding 1 percent or more of total amount of stock. If not owned by a corporation, the names and addresses of the individual owners must be given. If owned by a partnership or other unincorporated firm, its name and address, as well as that of each individual must be given.) Colorado Fiber Center, Inc. 1900 55th St., Boulder, CO 80301		
8. NAME AND ADDRESS		
Clotilde Barrett	624 Peakview, Boulder, CO 80302	
Earl B. Barrett	same	
Maxine Wendler	2207 Juniper Av. Boulder, CO 80302	
Kenneth Barrett	624 Peakview, Boulder, CO 80302	
Ingrid Barrett	733 Robertson Way, Sacramento, CA 95818	
9. FOR COMPLETION BY NONPROFIT ORGANIZATIONS AUTHORIZED TO MAIL AT SPECIAL RATES (Section 132.122, PSN) The purpose, function, and nonprofit status of this organization and the exempt status for Federal income tax purposes (Check one)		
<input type="checkbox"/> HAVE NOT CHANGED DURING PRECEDING 12 MONTHS <input type="checkbox"/> HAVE CHANGED DURING PRECEDING 12 MONTHS (If changed, publisher must submit explanation of change with this statement.)		
10. EXTENT AND NATURE OF CIRCULATION	AVERAGE NO. COPIES EACH ISSUE DURING PRECEDING 12 MONTHS	ACTUAL NO. COPIES OF SINGLE ISSUE PUBLISHED NEAREST TO FILING DATE
A. TOTAL NO. COPIES PRINTED (Net Press Run)	3250	4000
B. PAID CIRCULATION 1. SALES THROUGH DEALERS AND CARRIERS, STREET VENDORS AND COUNTER SALES	606	604
2. MAIL SUBSCRIPTIONS	1903	2097
C. TOTAL PAID CIRCULATION (Sum of 10B1 and 10B2)	2509	2701
D. FREE DISTRIBUTION BY MAIL, CARRIER OR OTHER MEANS SAMPLES, COMPLIMENTARY, AND OTHER FREE COPIES	137	104
E. TOTAL DISTRIBUTION (Sum of C and D)	2646	2805
F. COPIES NOT DISTRIBUTED 1. OFFICE USE, LEFT OVER, UNACCOUNTED, SPOILED AFTER PRINTING	604	1195
2. RETURNS FROM NEWS AGENTS	none	none
G. TOTAL (Sum of E, F1 and 2—should equal net press run shown in A)	3250	4000
11. I certify that the statements made by me above are correct and complete.	SIGNATURE AND TITLE OF EDITOR, PUBLISHER, BUSINESS MANAGER, OR OWNER <i>Clotilde O. Barrett</i>	
12. FOR COMPLETION BY PUBLISHERS MAILING AT THE REGULAR RATES (Section 132.121, Postal Service Manual) 39 U. S. C. 3626 provides in pertinent part: "No person who would have been entitled to mail matter under former section 4359 of this title shall mail such matter at the rates provided under this subsection unless he files annually with the Postal Service a written request for permission to mail matter at such rates." In accordance with the provisions of this statute, I hereby request permission to mail the publication named in Item 1 at the phased postage rates presently authorized by 39 U. S. C. 3626.		
SIGNATURE AND TITLE OF EDITOR, PUBLISHER, BUSINESS MANAGER, OR OWNER		

Announcing . . .

*Weaver's Journal
Monographs*

Monograph No. 1 BOLIVIAN
TUBLAR EDGING and CROSSED-
WARP TECHNIQUES by Adele
Cahlender. Price \$3.00 50¢ handling.



Monograph No. 2 Summer and Winter by Clotilde Barrett. Available 1979.

(Retailers and bookstores, inquire about wholesale prices).

The Weaver's Journal

Available back issues: Vol. I, No. 1, 2, 3; Vol. II, No. 2, 3, 4; Vol. III, No. 1 at \$2.50 per copy.
(Includes handling) (Colorado residents add 3½% sales tax). Allow 6 weeks delivery.

Reprint from *The Weaver's Journal*, Vol. I, No. 4 WOVEN and OTHER TEXTILE
MINIATURES. Price \$1.00 (Includes handling)

Order from: *The Weaver's Journal*, 1900 55th Street, Boulder, Colorado 80301

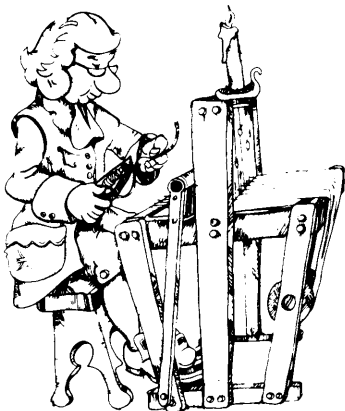

- Looms
- Yarns
- Books
- Work-Shops
- Spinning Supplies
- Macrame Materials

For unique yarn samples send \$1.00 and a self-addressed stamped envelope to:

**The Weaver's
Shop & Yarn Co.**

39 Courtland Dept. WJ
Rockford, Michigan 49341
Phone: 616-866-2531



Supplier for the
Fiber Arts

1905 South Pearl
Denver, Colorado 80210
777-2331

weaving spinning
knitting basketry
crocheting batik
dyeing macrame
instruction books

an ALTERNATIVE for the
COLORADO WEAVER and
CRAFTSPERSON

consignments
hrs. 10:00 - 6:00 Tues.-Sat.