

CSc 466/566

## Computer Security

# 6 : Cryptography — Symmetric Key

Version: 2013/02/26 13:16:51

Department of Computer Science  
University of Arizona

[collberg@gmail.com](mailto:collberg@gmail.com)

Copyright © 2013 Christian Collberg

Christian Collberg

# Outline

- 1 Introduction
- 2 DES
  - Key Schedule
  - The Rounds
  - The  $f$  Function
  - Decryption
  - Modes of Operation
  - Security
  - Software
  - Problems
- 3 AES
- 4 Summary

# Block Ciphers

- **Block ciphers** work on one block of data at a time. Different ciphers use different block size and key length:

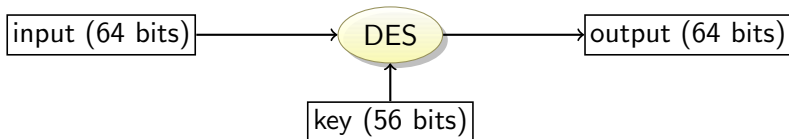

# Block Ciphers

- **Block ciphers** work on one block of data at a time. Different ciphers use different block size and key length:

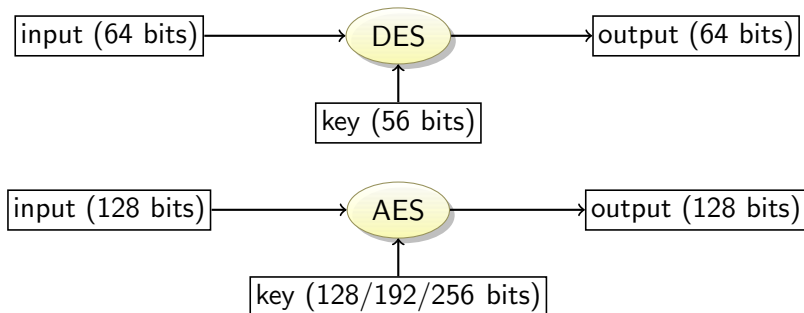

# Outline

- 1 Introduction
- 2 DES
  - Key Schedule
  - The Rounds
  - The  $f$  Function
  - Decryption
  - Modes of Operation
  - Security
  - Software
  - Problems
- 3 AES
- 4 Summary

- *Data Encryption Standard*. Designed by IBM and “certified” by NSA. Widely used in industry. The NSA is rumored to be able to break it in 3–15 minutes.
- A block cipher. Blocks are 64 bits, keys 56 bits:

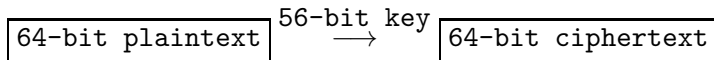

- DES is a symmetric algorithm; the same key and algorithm is used for encryption and decryption.
- The running example has been taken from J. Orlin Grabbe, *The DES Algorithm Illustrated*, <http://orlingrabbe.com/des.htm>.

- RSA Conference 2011 Keynote - The Cryptographers' Panel:  
<http://www.youtube.com/watch?v=0N1Zpyk3PKI>
- *DESVisual: A visualization tool for the DES Cipher*  
<http://www.cs.mtu.edu/~shene/NSF-4/ccsc2011.pdf> <http://www.cs.mtu.edu/~shene/NSF-4>.
- The Data Encryption Standard -Cryptography-Professor Dan Boneh: <http://www.youtube.com/watch?v=UgFoqxKY7cY>

# Confusion and Diffusion

- DES is a combination of two basic principles:
  - **confusion:** Confusion scrambles up the letters of the plaintext so that it has no direct relationship to the ciphertext. Substitution ciphers do this.
  - **diffusion:** Diffusion spreads the plaintext out over the ciphertext. Transposition (AKA permutation) ciphers do this.
- DES has 16 rounds. Each round consists of a substitution followed by a permutation.



# Key Schedule

- DES runs in 16 rounds.
- At each round we need a 48 bit key.
- We take the original 64 bit key, and extract 56 bits.
- In each round a new version of the key is generated to be used in the next round:
  - 1 Split the key into two halves, each 28 bits.
  - 2 Shift each half by 1 or 2 steps.
  - 3 Compress the two halves into 48 bits using the *Compression Permutation*,
  - 4 Merge the two shifted halves into the key for the next round.

# Key Schedule. . .

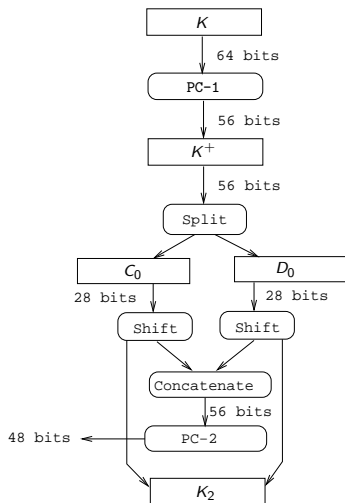

## Key Schedule — Initial Permutation

- We permute the 64 bits of the key according to table PC-1:

57	49	41	33	25	17	9
1	58	50	42	34	26	18
10	2	59	51	43	35	27
19	11	3	60	52	44	36
63	55	47	39	31	23	15
7	62	54	46	38	30	22
14	6	61	53	45	37	29
21	13	5	28	20	12	4

- Bit 57 of original key → bit 1 of permuted key.
- Bit 49 of original key → bit 2 of permuted key.
- Note: there are 56 entries in the table ⇒ we discard 8 original bits. I.e. bits numbered 8, 16, 24, 32, 40, 48, 56, and 64 are missing in the table.

# Key Schedule — Initial Permutation — Example

57	49	41	33	25	17	9
1	58	50	42	34	26	18
10	2	59	51	43	35	27
19	11	3	60	52	44	36
63	55	47	39	31	23	15
7	62	54	46	38	30	22
14	6	61	53	45	37	29
21	13	5	28	20	12	4

Original 64-bit key,  $K$

00010011 00110100 01010111 01111001 10011011 10111100 11011111 11110000

56-bit permutation,  $K^+$

1111000 0110011 0010101 0101111 0101010 1011001 1001111 0001111

## Key Schedule — Split the Key

- Next, the 56-bit permuted key is split key into a left and a right half,  $C_0$  and  $D_0$ , each 28 bits.

56-bit permutation,  $K^+$

---

1111000 0110011 0010101 0101111 0101010 1011001 1001111 0001111

Split in left and right half

---

$i$	$C_i$	$D_i$
0	1111000 0110011 0010101 0101111	0101010 1011001 1001111 0001111

## Key Schedule — Rotate the Key

- Next, generate 16 key-halves  $C_i, D_i, 1 \leq i \leq 16$  by rotating 1 or 2 bits.
- The table below expresses by how much (1 or 2 steps) the key should be circularly shifted each round.
- Because of this shift, a different part of the key will be used in each round.

Round	1	2	3	4	5	6	7	8	9	10	11	12	13	14	15	16
Shift	1	1	2	2	2	2	2	2	2	1	2	2	2	2	2	1

$i$	$C_i$	$D_i$	$\ll$
0	1111000011001100101010101111	0101010101100110011110001111	
1	1110000110011001010101011111	1010101011001100111100011110	1
2	1100001100110010101010111111	0101010110011001111000111101	1
3	0000110011001010101011111111	0101011001100111100011110101	2
4	0011001100101010101111111100	0101100110011110001111010101	2
5	1100110010101010111111110000	0110011001111000111101010101	2
6	0011001010101011111111000011	1001100111100011110101010101	2
7	1100101010101111111100001100	0110011110001111010101010110	2
8	0010101010111111110000110011	1001111000111101010101011001	2
9	0101010101111111100001100110	0011110001111010101010110011	2
10	0101010111111110000110011001	1111000111101010101011001100	2
11	0101011111111000011001100101	11000111110101010101100110011	1
12	0101111111100001100110010101	0001111010101010110011001111	2
13	0111111110000110011001010101	0111101010101011001100111100	2
14	1111111000011001100101010101	1110101010101100110011110001	2
15	1111100001100110010101010111	1010101010110011001111000111	2
16	1111000011001100101010101111	0101010101100110011110001111	1

## Key Schedule — Concatenate the Keys

- Next, concatenate the key, forming a 56 bit key.



$i$	$C_i D_i$
0	11110000110011001010101011110101010101100110011110001111
1	11100001100110010101010111111010101011001100111100011110
2	11000011001100101010101111110101010110011001111000111101
3	0000110011001010101011111110101011001100111100011110101
4	0011001100101010101111111000101100110011110001111010101
5	1100110010101010111111100000110011001111000111101010101
6	0011001010101011111110000111001100111100011110101010101
7	1100101010101111111000011000110011110001111010101010110
8	0010101010111111100001100111001111000111101010101011001
9	0101010101111111000011001100011110001111010101010110011
10	0101010111111100001100110011111000111101010101011001100
11	0101011111110000110011001011100011110101010101100110011
12	0101111111000011001100101010001111010101010110011001111
13	0111111100001100110010101010111101010101011001100111100
14	1111110000110011001010101011110101010101100110011110001
15	11111000011001100101010101111010101010110011001111000111
16	11110000110011001010101011110101010101100110011110001111

## Key Schedule — Compress the Keys

- Next, permute and compress the key into 48 bits, using the PC-2 table:

14	17	11	24	1	5
3	28	15	6	21	10
23	19	12	4	26	8
16	7	27	20	13	2
41	52	31	37	47	55
30	40	51	45	33	48
44	49	39	56	34	53
46	42	50	36	29	32

- Bit 1 of  $K_n$  is bit 14 of  $C_n D_n$ .
- Bit 2 of  $K_n$  is bit 17 of  $C_n D_n$ .

## Key Schedule — Compress the Keys...

14	17	11	24	1	5
3	28	15	6	21	10
23	19	12	4	26	8
16	7	27	20	13	2
41	52	31	37	47	55
30	40	51	45	33	48
44	49	39	56	34	53
46	42	50	36	29	32

- Example:  $C_1 D_1 =$

1110000 1100110 0101010 1011111 1010101 0110011 0011110 0011110

- After permutation becomes  $K_1 =$

000110 110000 001011 101111 111111 000111 000001 110010

# Key Schedule — Final Keys

$i$	$K_i$							
1	000110	110000	001011	101111	111111	000111	000001	110010
2	011110	011010	111011	011001	110110	111100	100111	100101
3	010101	011111	110010	001010	010000	101100	111110	011001
4	011100	101010	110111	010110	110110	110011	010100	011101
5	011111	001110	110000	000111	111010	110101	001110	101000
6	011000	111010	010100	111110	010100	000111	101100	101111
7	111011	001000	010010	110111	111101	100001	100010	111100
8	111101	111000	101000	111010	110000	010011	101111	111011
9	111000	001101	101111	101011	111011	011110	011110	000001
10	101100	011111	001101	000111	101110	100100	011001	001111
11	001000	010101	111111	010011	110111	101101	001110	000110
12	011101	010111	000111	110101	100101	000110	011111	101001
13	100101	111100	010111	010001	111110	101011	101001	000001
14	010111	110100	001110	110111	111100	101110	011100	111010
15	101111	111001	000110	001101	001111	010011	111100	001010
16	110010	110011	110110	001011	000011	100001	011111	110101

# Key Schedule — Summary

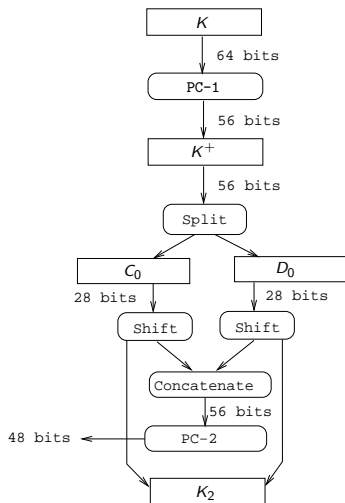

# Initial Data Permutation

- We first permute the 64-bit data block with permutation table IP:

58	50	42	34	26	18	10	2
60	52	44	36	28	20	12	4
62	54	46	38	30	22	14	6
64	56	48	40	32	24	16	8
57	49	41	33	25	17	9	1
59	51	43	35	27	19	11	3
61	53	45	37	29	21	13	5
63	55	47	39	31	23	15	7

- Bit 58 of  $M$  becomes the bit 1.
- Bit 50 of  $M$  becomes the bit 2.

# Initial Data Permutation...

- Plaintext  $M = 0123456789ABCDEF$

58	50	42	34	26	18	10	2
60	52	44	36	28	20	12	4
62	54	46	38	30	22	14	6
64	56	48	40	32	24	16	8
57	49	41	33	25	17	9	1
59	51	43	35	27	19	11	3
61	53	45	37	29	21	13	5
63	55	47	39	31	23	15	7

$M$

0000 0001 0010 0011 0100 0101 0110 0111 1000 1001 1010 1011 1100 1101 1110 1111

$IP(M)$

1100 1100 0000 0000 1100 1100 1111 1111 1111 0000 1010 1010 1111 0000 1010 1010

# Splitting the Input Block

- Next, we split the permuted 64-bit data block into a left and a right half,  $L_0$  and  $R_0$ :

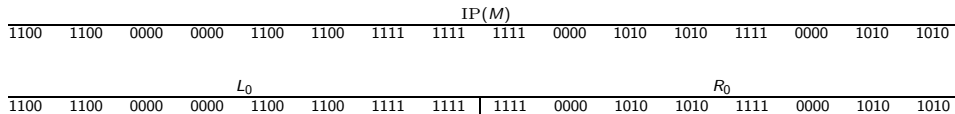



# The Rounds

- We iterate 16 times, for  $1 \leq i \leq 16$ , computing:

$$L_n = R_{n-1}$$

$$R_n = L_{n-1} \oplus f(R_{n-1}, K_n)$$

- In each iteration, the right 32 bits of the previous result become the left 32 bits of the current step.
- We XOR the left 32 bits of the previous step with the calculation  $f$  on the key and the right 32 bits.
- At the end, we have a final block  $L_{16}R_{16}$ .

# The Rounds...

① Split 64-bit input into  $L_0$  and  $R_0$ , each 32 bits.

② Round 1:

$$\begin{aligned}L_1 &= R_0 \\R_1 &= L_0 \oplus f(R_0, K_1)\end{aligned}$$

③ Round  $i$ :

$$\begin{aligned}L_i &= R_{i-1} \\R_i &= L_{i-1} \oplus f(R_{i-1}, K_i)\end{aligned}$$

④ Round 16:

$$\begin{aligned}L_{16} &= R_{15} \\R_{16} &= L_{15} \oplus f(R_{15}, K_{16})\end{aligned}$$

⑤ Return the 64-bit ciphertext  $L_{16}R_{16}$ .

# The Rounds...

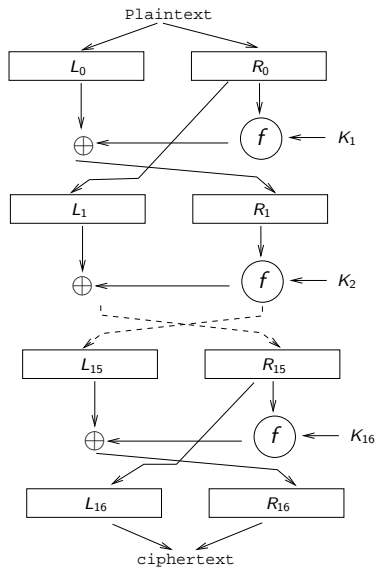

# Example

- Let  $n = 1$ .
- $K_1 =$   
000110 110000 001011 101111 111111 000111 000001 110010
- $L_1 = R_0 = 1111\ 0000\ 1010\ 1010\ 1111\ 0000\ 1010\ 1010$
- $R_1 = L_0 + f(R_0, K_1)$

# The $f$ Function

- $f$  is the function that combines the data (the right 32-bit half,  $R$ ) with the key during each round:
  - 1 Get 48 bits of the key,
  - 2 Expand  $R$  to 48 bits using the *expansion permutation*,
  - 3 XOR the expanded  $R$  and the compressed key,
  - 4 Send the result through 8 S-boxes using the *S-Box Substitution* to get 32 new bits,
  - 5 Permute the result using the *P-Box Permutation*,
- The result of the  $f$  function is XOR:ed with the left half ( $L$ ) to get the new right half.
- $f$  stands for **Feistel**, named after German-born physicist and cryptographer Horst Feistel.

# The $f$ Function...

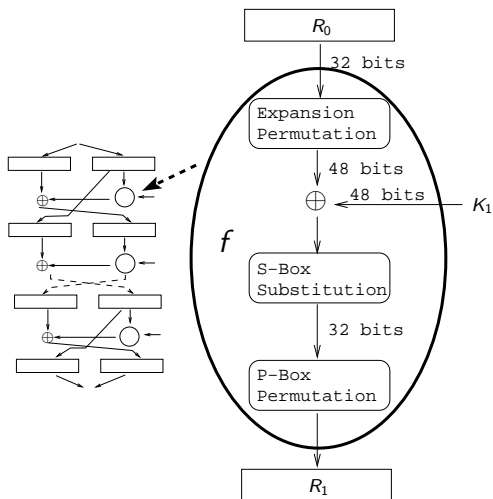

# Expansion Permutation

- The expansion permutation takes the 32 bits of  $R$ , permutes these bits, and, by copying some of them, expands  $R$  into 48 bits.
- The table  $E$  below says that bit 32 of  $R$  moves into position 1, bit 1 moves to 2, 2 to 3, 4 to 5, 5 to 6, 4 to 7, 5 to 8, etc.

32	1	2	3	4	5	4	5	6	7	8	9
8	9	10	11	12	13	12	13	14	15	16	17
16	17	18	19	20	21	20	21	22	23	24	25
24	25	26	27	28	29	28	29	30	31	32	1

## Expansion Permutation...

32	1	2	3	4	5	4	5	6	7	8	9
8	9	10	11	12	13	12	13	14	15	16	17
16	17	18	19	20	21	20	21	22	23	24	25
24	25	26	27	28	29	28	29	30	31	32	1

- Calculate  $E(R_0)$  from  $R_0$
- $R_0 = 1111\ 0000\ 1010\ 1010\ 1111\ 0000\ 1010\ 1010$
- $E(R_0) =$   
011110 100001 010101 010101 011110 100001 010101 010101
- Notice how every 4-bit block has now become 8 bits.



## XOR:ing in the Key

- Next the output  $E(R_n - 1)$  is XOR:ed the key  $K_n$ :

$$K_n \oplus E(R_n - 1).$$

- For  $K_1$  ,  $E(R_0)$ :

$$\begin{aligned} K_1 &= 000110\ 110000\ 001011\ 101111\ 111111\ 000111\ 000001\ 110010 \\ E(R_0) &= 011110\ 100001\ 010101\ 010101\ 011110\ 100001\ 010101\ 010101 \\ K_1 \oplus E(R_0) &= 011000\ 010001\ 011110\ 111010\ 100001\ 100110\ 010100\ 100111. \end{aligned}$$

# S-Box Substitution

- The expanded right ( $R_{i-1}$ ) and the compressed key ( $K_i$ ) are XORed together. The 48-bit result is then passed through 8 S-Boxes (Substitution Boxes) to form 32 bits.
- Each one of the 8 S-Boxes is different. Each takes 6 bits of input and produces 4 bits of output:

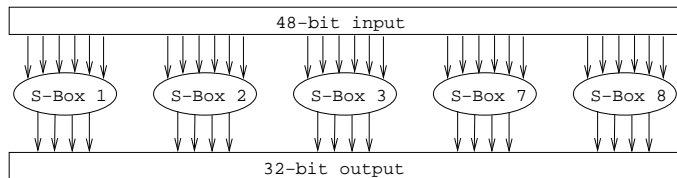

# S-Box Substitution Tables

- Each S-Box is given by a table consisting of 4 rows of 16 numbers. Each number is a 4-bit quantity.
- The input to each S-Box is 6 bits:

$b_1$	$b_2$	$b_3$	$b_4$	$b_5$	$b_6$
-------	-------	-------	-------	-------	-------

- The S-Box table is indexed by taking the outer 2 bits ( $b_1$  and  $b_6$ ) and forming a number between 0 and 3. This is used to get the row number, The middle 4 bits ( $b_2 \cdots b_5$ ) get the column number.
- The S-Boxes are what gives DES its security.

# S-Box Substitution: S-Box 1

row	column number															
	0	1	2	3	4	5	6	7	8	9	10	11	12	13	14	15
0	14	4	13	1	2	15	11	8	3	10	6	12	5	9	0	7
1	0	15	7	4	14	2	13	1	10	6	12	11	9	5	3	8
2	4	1	14	8	13	6	2	11	15	12	9	7	3	10	5	0
3	15	12	8	2	4	9	1	7	5	11	3	14	10	0	6	13

- Input block  $B = b_1b_2b_3b_4b_5b_6 = 011011$ .
- Row index =  $b_1b_6 = 01_2 = 1_{10}$
- Column index =  $b_2b_3b_4b_5 = 1101_2 = 13_{10}$ .
- $\Rightarrow S_1(011011) = 5_{10} = 0101_2$ .

# S-Box Substitution

## S-Box 1

14	4	13	1	2	15	11	8	3	10	6	12	5	9	0	7
0	15	7	4	14	2	13	1	10	6	12	11	9	5	3	8
4	1	14	8	13	6	2	11	15	12	9	7	3	10	5	0
15	12	8	2	4	9	1	7	5	11	3	14	10	0	6	13

## S-Box 2

15	1	8	14	6	11	3	4	9	7	2	13	12	0	5	10
3	13	4	7	15	2	8	14	12	0	1	10	6	9	11	5
0	14	7	11	10	4	13	1	5	8	12	6	9	3	2	15
13	8	10	1	3	15	4	2	11	6	7	12	0	5	14	9

## S-Box 3

10	0	9	14	6	3	15	5	1	13	12	7	11	4	2	8
13	7	0	9	3	4	6	10	2	8	5	14	12	11	15	1
13	6	4	9	8	15	3	0	11	1	2	12	5	10	14	7
1	10	13	0	6	9	8	7	4	15	14	3	11	5	2	12

## S-Box 4

7	13	14	3	0	6	9	10	1	2	8	5	11	12	4	15
13	8	11	5	6	15	0	3	4	7	2	12	1	10	14	9
10	6	9	0	12	11	7	13	15	1	3	14	5	2	8	4
3	15	0	6	10	1	13	8	9	4	5	11	12	7	2	14

# S-Box Substitution

## S-Box 5

2	12	4	1	7	10	11	6	8	5	3	15	13	0	14	9
14	11	2	12	4	7	13	1	5	0	15	10	3	9	8	6
4	2	1	11	10	13	7	8	15	9	12	5	6	3	0	14
11	8	12	7	1	14	2	13	6	15	0	9	10	4	5	3

## S-Box 6

12	1	10	15	9	2	6	8	0	13	3	4	14	7	5	11
10	15	4	2	7	12	9	5	6	1	13	14	0	11	3	8
9	14	15	5	2	8	12	3	7	0	4	10	1	13	11	6
4	3	2	12	9	5	15	10	11	14	1	7	6	0	8	13

## S-Box 7

4	11	2	14	15	0	8	13	3	12	9	7	6	10	6	1
13	0	11	7	4	9	1	10	14	3	5	12	2	15	8	6
1	4	11	13	12	3	7	14	10	15	6	8	0	5	9	2
6	11	13	8	1	4	10	7	9	5	0	15	14	2	3	12

## S-Box 8

13	2	8	4	6	15	11	1	10	9	3	14	5	0	12	7
1	15	13	8	10	3	7	4	12	5	6	11	0	14	9	2
7	11	4	1	9	12	14	2	0	6	10	13	15	3	5	8
2	1	14	7	4	10	8	13	15	12	9	0	3	5	6	11

# P-Box Permutation Tables

- The final operation in the  $f$  function is the P-Box.
- It's a straight permutation of the 32 bits that come out of the S-Box.
- Bit number 16 moves into position 1, bit 7 into 2, 20 into 3, etc:

16	7	20	21	29	12	28	17	1	15	23	26	5	18	31	10
2	8	24	14	32	27	3	9	19	13	30	6	22	11	4	25

# Decryption

- The same algorithm we just described for encryption can also be used for decryption.
- However, we have to use the keys in the reverse order.
- That is, during decryption we use the keys

$$K_{16}, K_{15}, \dots, K_2, K_1.$$



# Decryption

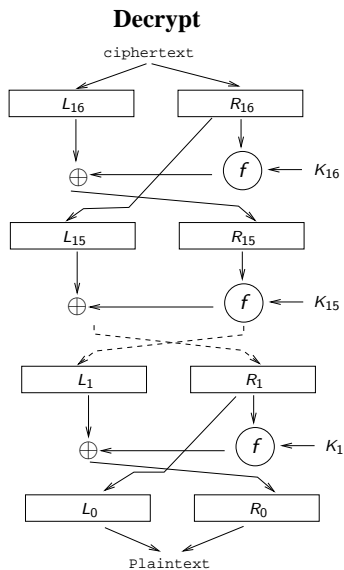
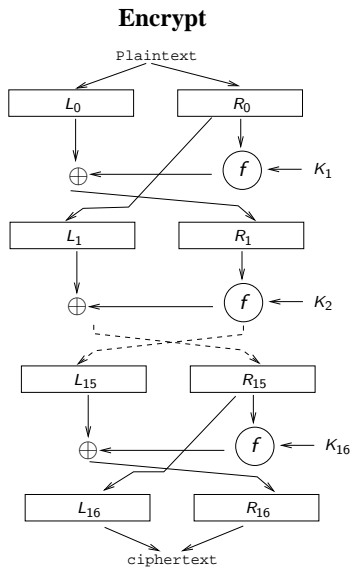

# Decryption — 1 Round

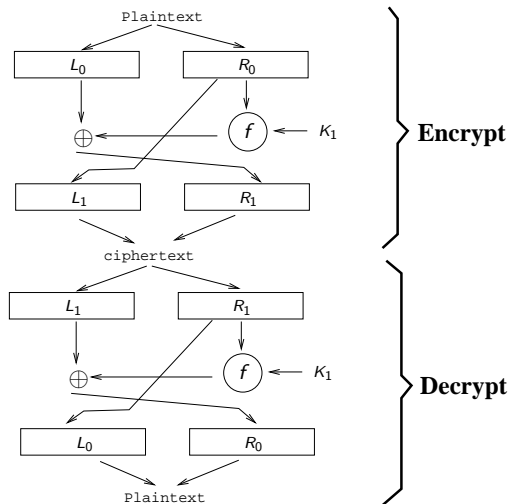

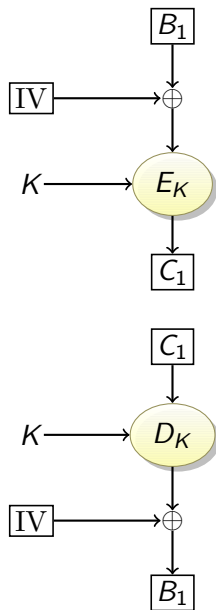

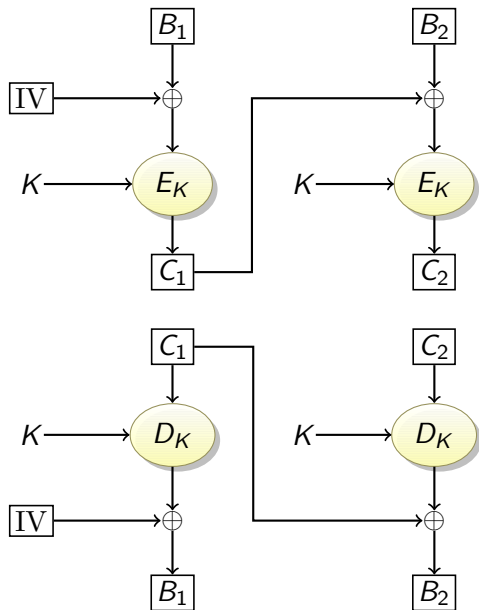

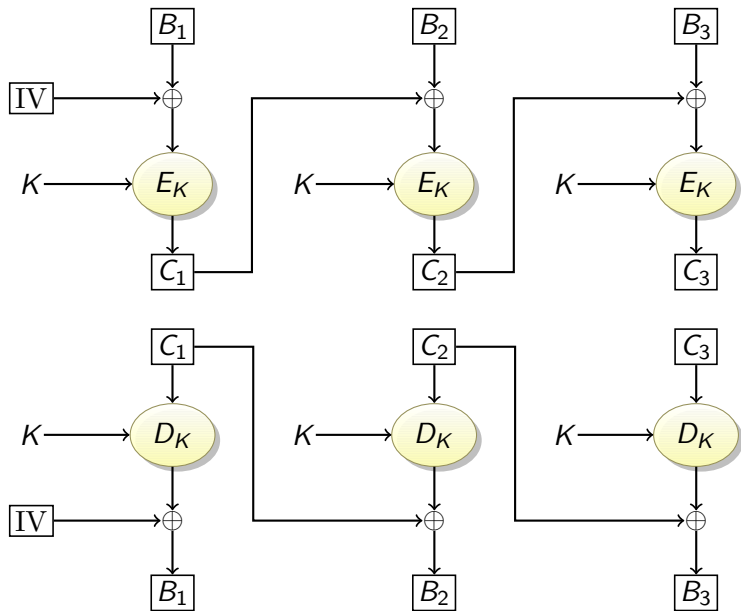

# Triple DES

- Three DES keys,  $K_1$ ,  $K_2$  and  $K_3$ , each 64 bits (56 bits of actual key + 8 parity bits).
- Blocks are still 64 bits.
- Encryption:

$$C = E_{K_3}(D_{K_2}(E_{K_1}(M)))$$

DES encrypt with  $K_1$ , DES decrypt with  $K_2$ , then DES encrypt with  $K_3$ .

- Decryption:

$$M = D_{K_1}(E_{K_2}(D_{K_3}(C)))$$

Decrypt with  $K_3$ , encrypt with  $K_2$ , then decrypt with  $K_1$ .

# Triple DES — Picking keys

- There are three options for picking keys:
  - ① All three keys are independent (168 key bits)
  - ②  $K_1$  and  $K_2$  are independent,  $K_3 = K_1$  (112 key bits).
  - ③  $K_1 = K_2 = K_3$  (56 key bits).
- Option 3 is equivalent to DES, good for backwards compatibility.

# Weak keys

These keys are weak or semi-weak and should be avoided (p is **0** or **1**, P is **e** or **f**):

0x0p0p0p0p0p0p0p0p

0x0pep0pep0pfp0pfp

0x1P0p1P0p0P0p0P0p

0x1Pep1Pep0Pfp0Pfp

0xep0pep0pfp0pfp0p

0xepepepepepepepepep

0xfP0pfp0pfp0pfp0p

0xfPepfpPepfpPepfpPep

0x0p1P0p1P0p0P0p0P

0x0pfp0pfp0pfp0pfpP

0x1P1P1P1P0P0P0P0P

0x1Pfp1Pfp0Pfp0PfpP

0xep1Pep1pfp0Pfp0P

0xepfpPepfpPfpfpPfpP

0xfP1Pfp1Pfp0Pfp0P

0xfPfpPfpPfpPfpPfpP



# Software – openssl

```
> cat message
```

```
Attack at dawn, actually, no, let's make it 3 am  
since, you know, they expect us at dawn, but,  
maybe they will expect us at 3 am since, we  
said we'd attack at dawn, so let's attack at  
down anyway! Unless...
```

```
> openssl enc -e -des -in message -a \  
-out message.asc -pass pass:Alice4Evah
```

```
> cat message.asc
```

```
U2FsdGVkX1/hHZThWEArEyxc0Z6dT4s1zfdUovG+yCBNEpk1M+m7jevbg+bJpE9  
IgxkZLVzncgIWyKQQePLjbmBJfKVRBHCFdfbS+oi4dxj3PfMygm/HN5QjeC7TIJL  
muXX+c0SExJ4GKifxBO8VBT8baj8a06k2Qfex9JuXh0dHSqCf02GHgr4b7s/5us0  
OHgrVZP9RIaCMBEB+9uu6oDVlApK/GoWipf8/S5jz7qbdjjaT6Cw00+HIImNPEE9w  
k1xYs5CkNU6fVHH3b1SIyJHxxf6REUkxA3immtFVidsn2sOHJOg36A==
```

```
> openssl enc -d -des -in message.asc \  
-a -pass pass:Alice4Evah
```

Attack at dawn, actually, no, let's make it 3 am since, you know, they expect us at dawn, but, maybe they will expect us at 3 am since, we said we'd attack at dawn, so let's attack at dawn anyway! Unless...

# In-class Exercise: 2012 Midterm Exam

- Consider the following S-box  $S$  which maps 4 bits to 4 bits:

$S$	00	01	10	11
00	0010	1000	1101	1011
01	0100	0011	0101	1010
10	0000	1100	1110	1001
11	0001	0111	1111	0110

- Construct the corresponding inverted S-box  $S^{-1}$  that reverses the substitution!

# Outline

- 1 Introduction
- 2 DES
  - Key Schedule
  - The Rounds
  - The  $f$  Function
  - Decryption
  - Modes of Operation
  - Security
  - Software
  - Problems
- 3 AES
- 4 Summary

- Joan Daemen and Vincent Rijmen created Rijndael
- AES is based on Rijndael: iterated block cypher with variable block and key lengths
- AES and Rijndael differ only in the range of supported values for the block length and cipher key length
- Rijndael block length and key length can be specified to any multiple of 32 bits with a minimum of 128 bits
- AES fixes the block length to 128 bits and supports key lengths of 128, 192, or 256
- A Stick Figure Guide to the Advanced Encryption Standard (AES): <http://www.moserware.com/2009/09/stick-figure-guide-to-advanced.html>

- Rijndael design criteria
  - Resistance against all known attacks
  - Speed and code compactness on many platforms
  - Design simplicity

- Wide Trail Strategy provides resistance against linear and differential cryptanalysis
- Wide Trail Strategy layers:
  - Linear mixing layer: guarantees high diffusion over multiple rounds
  - Non-linear layer: parallel application of S-boxes
  - Key addition layer: XOR of the Round Key to the intermediate state

# Rijndael Specification - Transformations

- The different transformations operate on intermediate results called States
- `Round(State, RoundKey){`  
    `ByteSub(State);`  
    `ShiftRow(State);`  
    `MixColumn(State);`  
    `AddRoundKey(State, RoundKey);}`
- Final Round does not include `MixColumn(State)`



# Rijndael Specification - Key Schedule

- Round keys are derived from Cipher Key through a key schedule
- This consists of Key Expansion and Round Key Selection
- Total number of Round Key bits is the block length multiplied by the number of rounds plus 1 (for  $bl=128$  and  $r=9$ ,  $RK=1280$ )
- Cipher Key is expanded to an Expanded Key via S-boxes
- Round keys are taken from the Expanded Key

# Outline

- 1 Introduction
- 2 DES
  - Key Schedule
  - The Rounds
  - The  $f$  Function
  - Decryption
  - Modes of Operation
  - Security
  - Software
  - Problems
- 3 AES
- 4 **Summary**

# Readings and References

- Chapter 8.1.6 in *Introduction to Computer Security*, by Goodrich and Tamassia.
- The Enigma Secret: <http://www.youtube.com/watch?v=IJToxIZMbZQ&feature=related>
- J. Orlin Grabbe, The DES Algorithm Illustrated, <http://orlingrabbe.com/des.htm>.

# Acknowledgments

Additional material and exercises have also been collected from these sources:

- ① Igor Crk and Scott Baker, *620—Fall 2003—Basic Cryptography*.
- ② J. Orlin Grabbe, The DES Algorithm Illustrated,  
<http://orlingrabbe.com/des.htm>.